

R&S®FS-K100/102/104PC

R&S®FSV-K100/102/104

R&S®FSQ-K100/102/104

EUTRA / LTE Downlink PC Software

User Manual

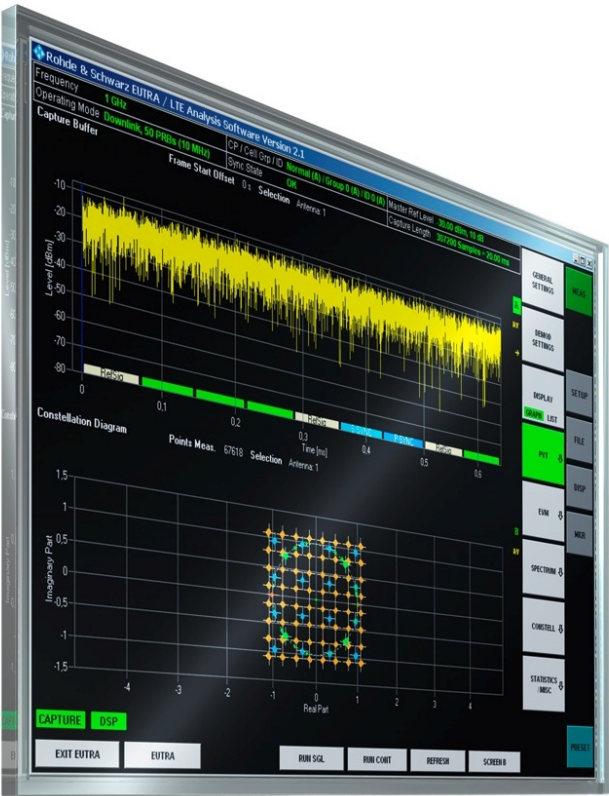

1308.9029.42 – 17

This manual covers the following products.

- R&S®FSQ-K100 (1308.9006.02)
- R&S®FSQ-K102 (1309.9000.02)
- R&S®FSQ-K104 (1309.9422.02)
- R&S®FSV-K100 (1310.9051.02)
- R&S®FSV-K102 (1310.9151.02)
- R&S®FSV-K104 (1309.9774.02)
- R&S®FS-K100PC (1309.9916.02)
- R&S®FS-K102PC (1309.9939.02)
- R&S®FS-K104PC (1309.9951.02)

The R&S®FS-K10xPC versions are available for the following spectrum and signal analyzers and oscilloscopes

- R&S®FSG
- R&S®FSQ
- R&S®FSV
- R&S®FSVR
- R&S®FSW
- R&S®RTO

The contents of the manual correspond to version 3.40 or higher.

© 2014 Rohde & Schwarz GmbH & Co. KG

Mühldorfstr. 15, 81671 München, Germany

Phone: +49 89 41 29 - 0

Fax: +49 89 41 29 12 164

E-mail: info@rohde-schwarz.com

Internet: www.rohde-schwarz.com

Subject to change – Data without tolerance limits is not binding.

R&S® is a registered trademark of Rohde & Schwarz GmbH & Co. KG.

Trade names are trademarks of the owners.

The following abbreviations are used throughout this manual: R&S®FS-K100/-K102/-K104 is abbreviated as R&S FS-K100/-K102/-K104.

Contents

1	Introduction.....	7
1.1	Requirements for UMTS Long-Term Evolution.....	7
1.2	Long-Term Evolution Downlink Transmission Scheme.....	9
1.2.1	OFDMA.....	9
1.2.2	OFDMA Parameterization.....	10
1.2.3	Downlink Data Transmission.....	12
1.2.4	Downlink Reference Signal Structure and Cell Search.....	12
1.2.5	Downlink Physical Layer Procedures.....	14
1.3	References.....	14
2	Welcome.....	16
2.1	Licensing the Software.....	16
2.2	Installing the Software.....	19
2.3	Connecting the Computer to an Analyzer.....	19
2.3.1	Instrument Configuration.....	19
2.3.2	Figuring Out IP Addresses.....	22
2.4	Application Overview.....	25
2.5	Configuring the Software.....	28
2.5.1	Configuring the Display.....	28
2.5.2	Configuring the Software.....	29
3	Measurements and Result Displays.....	31
3.1	Numerical Results.....	32
3.2	Measuring the Power Over Time.....	34
3.3	Measuring the Error Vector Magnitude (EVM).....	40
3.4	Measuring the Spectrum.....	45
3.4.1	Frequency Sweep Measurements.....	45
3.4.2	I/Q Measurements.....	49
3.5	Measuring the Symbol Constellation.....	52
3.6	Measuring Statistics.....	54
3.7	Measuring Beamforming.....	60
3.8	3GPP Test Scenarios.....	66

4	General Settings	68
4.1	Configuring the Measurement	68
4.1.1	Defining General Signal Characteristics	68
4.1.2	Configuring the Input	69
4.1.3	Configuring the Input Level	70
4.1.4	Configuring the Data Capture	72
4.1.5	Configuring Measurement Results	74
4.1.6	Configuring Time Alignment Measurements	76
4.1.7	Configuring Transmit On/Off Power Measurements	77
4.2	Configuring MIMO Measurement Setups	78
4.3	Triggering Measurements	81
4.4	Spectrum Settings	82
4.4.1	Configuring SEM and ACLR Measurements	82
4.5	Advanced Settings	84
4.5.1	Controlling I/Q Data	84
4.5.2	Configuring the Baseband Input	85
4.5.3	Using Advanced Input Settings	86
4.5.4	Configuring the Digital I/Q Input	86
4.5.5	Global Settings	87
4.5.6	Mapping Antenna Ports	88
5	Demod Settings	89
5.1	Configuring Downlink Signal Demodulation	89
5.1.1	Selecting the Demodulation Method	89
5.1.2	Configuring Multicarrier Base Stations	90
5.1.3	Configuring Parameter Estimation	91
5.1.4	Compensating Signal Errors	91
5.1.5	Configuring EVM Measurements	92
5.1.6	Processing Demodulated Data	93
5.1.7	Configuring MIMO Setups	94
5.2	Defining Downlink Signal Characteristics	95
5.2.1	Defining the Physical Signal Characteristics	95
5.2.2	Configuring the Physical Layer Cell Identity	97
5.2.3	Configuring MIMO Measurements	98

5.2.4	Configuring PDSCH Subframes.....	99
5.3	Defining Advanced Signal Characteristics.....	105
5.3.1	Configuring the Synchronization Signal.....	105
5.3.2	Configuring the Reference Signal.....	106
5.3.3	Configuring Positioning Reference Signals.....	106
5.3.4	Configuring Channel State Information Reference Signal.....	108
5.3.5	Defining the PDSCH Resource Block Symbol Offset.....	110
5.3.6	Configuring the Control Channels.....	110
5.3.7	Configuring the Shared Channel.....	115
5.4	Defining MBSFN Characteristics.....	116
5.4.1	Configuring MBSFNs.....	116
5.4.2	Configuring MBSFN Subframes.....	117
6	Analyzing Measurement Results.....	119
7	Data Management.....	122
7.1	Importing and Exporting I/Q Data.....	122
7.2	Managing Frame Data.....	123
7.3	Importing and Exporting Limits.....	124
8	Measurement Basics.....	126
8.1	Symbols and Variables.....	126
8.2	Overview.....	127
8.3	The LTE Downlink Analysis Measurement Application.....	127
8.3.1	Synchronization.....	127
8.3.2	Channel Estimation and Equalization.....	129
8.3.3	Analysis.....	129
8.4	MIMO Measurement Guide.....	130
8.4.1	MIMO Measurements with Signal Analyzers.....	131
8.4.2	MIMO Measurements with Oscilloscopes.....	135
8.5	Calibrating Beamforming Measurements.....	136
8.6	Performing Time Alignment Measurements.....	138
8.7	Performing Transmit On/Off Power Measurements.....	140
9	Remote Commands.....	142
9.1	Overview of Remote Command Suffixes.....	142

9.2 Introduction.....	143
9.2.1 Long and Short Form.....	143
9.2.2 Numeric Suffixes.....	144
9.2.3 Optional Keywords.....	144
9.2.4 (Vertical Stroke).....	144
9.2.5 SCPI Parameters.....	145
9.3 Remote Commands to Select a Result Display.....	147
9.4 Remote Commands to Perform Measurements.....	148
9.5 Remote Commands to Read Numeric Results.....	151
9.6 Remote Commands to Read Trace Data.....	158
9.6.1 Using the TRACe[:DATA] Command.....	158
9.6.2 Reading Out Limit Check Results.....	173
9.7 Remote Commands to Configure General Settings.....	181
9.7.1 Remote Commands for General Settings.....	181
9.7.2 Configuring MIMO Measurement Setups.....	190
9.7.3 Using a Trigger.....	192
9.7.4 Configuring Spectrum Measurements.....	194
9.7.5 Remote Commands for Advanced Settings.....	196
9.8 Remote Command to Configure the Demodulation.....	199
9.8.1 Remote Commands for PDSCH Demodulation Settings.....	199
9.8.2 Remote Commands for DL Signal Characteristics.....	204
9.8.3 Remote Commands for DL Advanced Signal Characteristics.....	213
9.8.4 Remote Commands for MBSFN Settings.....	223
9.9 Configuring the Software.....	225
9.10 Managing Files.....	226
List of Commands.....	229
Index.....	234

1 Introduction

Currently, UMTS networks worldwide are being upgraded to high speed downlink packet access (HSDPA) in order to increase data rate and capacity for downlink packet data. In the next step, high speed uplink packet access (HSUPA) will boost uplink performance in UMTS networks. While HSDPA was introduced as a 3GPP Release 5 feature, HSUPA is an important feature of 3GPP Release 6. The combination of HSDPA and HSUPA is often referred to as HSPA.

However, even with the introduction of HSPA, the evolution of UMTS has not reached its end. HSPA+ will bring significant enhancements in 3GPP Release 7. The objective is to enhance the performance of HSPA-based radio networks in terms of spectrum efficiency, peak data rate and latency, and to exploit the full potential of WCDMA-based 5 MHz operation. Important features of HSPA+ are downlink multiple input multiple output (MIMO), higher order modulation for uplink and downlink, improvements of layer 2 protocols, and continuous packet connectivity.

In order to ensure the competitiveness of UMTS for the next 10 years and beyond, concepts for UMTS long term evolution (LTE) have been investigated. The objective is a high-data-rate, low-latency and packet-optimized radio access technology. Therefore, a study item was launched in 3GPP Release 7 on evolved UMTS terrestrial radio access (EUTRA) and evolved UMTS terrestrial radio access network (EUTRAN). LTE/EUTRA will then form part of 3GPP Release 8 core specifications.

This introduction focuses on LTE/EUTRA technology. In the following, the terms LTE or EUTRA are used interchangeably.

In the context of the LTE study item, 3GPP work first focused on the definition of requirements, e.g. targets for data rate, capacity, spectrum efficiency, and latency. Also commercial aspects such as costs for installing and operating the network were considered. Based on these requirements, technical concepts for the air interface transmission schemes and protocols were studied. Notably, LTE uses new multiple access schemes on the air interface: orthogonal frequency division multiple access (OFDMA) in downlink and single carrier frequency division multiple access (SC-FDMA) in uplink. Furthermore, MIMO antenna schemes form an essential part of LTE. In an attempt to simplify protocol architecture, LTE brings some major changes to the existing UMTS protocol concepts. Impact on the overall network architecture including the core network is being investigated in the context of 3GPP system architecture evolution (SAE).

- [Requirements for UMTS Long-Term Evolution](#)..... 7
- [Long-Term Evolution Downlink Transmission Scheme](#).....9
- [References](#)..... 14

1.1 Requirements for UMTS Long-Term Evolution

LTE is focusing on optimum support of packet switched (PS) services. Main requirements for the design of an LTE system are documented in 3GPP TR 25.913 [1] and can be summarized as follows:

- Data Rate: Peak data rates target 100 Mbps (downlink) and 50 Mbps (uplink) for 20 MHz spectrum allocation, assuming two receive antennas and one transmit antenna are at the terminal.
- Throughput: The target for downlink average user throughput per MHz is three to four times better than Release 6. The target for uplink average user throughput per MHz is two to three times better than Release 6.
- Spectrum efficiency: The downlink target is three to four times better than Release 6. The uplink target is two to three times better than Release 6.
- Latency: The one-way transit time between a packet being available at the IP layer in either the UE or radio access network and the availability of this packet at IP layer in the radio access network/UE shall be less than 5 ms. Also C-plane latency shall be reduced, e.g. to allow fast transition times of less than 100 ms from camped state to active state.
- Bandwidth: Scaleable bandwidths of 5 MHz, 10 MHz, 15 MHz, and 20 MHz shall be supported. Also bandwidths smaller than 5 MHz shall be supported for more flexibility.
- Interworking: Interworking with existing UTRAN/GERAN systems and non-3GPP systems shall be ensured. Multimode terminals shall support handover to and from UTRAN and GERAN as well as inter-RAT measurements. Interruption time for handover between EUTRAN and UTRAN/GERAN shall be less than 300 ms for realtime services and less than 500 ms for non-realtime services.
- Multimedia broadcast multicast services (MBMS): MBMS shall be further enhanced and is then referred to as E-MBMS.
- Costs: Reduced CAPEX and OPEX including backhaul shall be achieved. Cost-effective migration from Release 6 UTRA radio interface and architecture shall be possible. Reasonable system and terminal complexity, cost, and power consumption shall be ensured. All the interfaces specified shall be open for multivendor equipment interoperability.
- Mobility: The system should be optimized for low mobile speed (0 to 15 km/h), but higher mobile speeds shall be supported as well, including high speed train environment as a special case.
- Spectrum allocation: Operation in paired (frequency division duplex / FDD mode) and unpaired spectrum (time division duplex / TDD mode) is possible.
- Co-existence: Co-existence in the same geographical area and co-location with GERAN/UTRAN shall be ensured. Also, co-existence between operators in adjacent bands as well as cross-border co-existence is a requirement.
- Quality of Service: End-to-end quality of service (QoS) shall be supported. VoIP should be supported with at least as good radio and backhaul efficiency and latency as voice traffic over the UMTS circuit switched networks.
- Network synchronization: Time synchronization of different network sites shall not be mandated.

1.2 Long-Term Evolution Downlink Transmission Scheme

1.2.1 OFDMA

The downlink transmission scheme for EUTRA FDD and TDD modes is based on conventional OFDM.

In an OFDM system, the available spectrum is divided into multiple carriers, called sub-carriers, which are orthogonal to each other. Each of these subcarriers is independently modulated by a low rate data stream.

OFDM is used as well in WLAN, WiMAX and broadcast technologies like DVB. OFDM has several benefits including its robustness against multipath fading and its efficient receiver architecture.

figure 1-1 shows a representation of an OFDM signal taken from 3GPP TR 25.892 [2]. In this figure, a signal with 5 MHz bandwidth is shown, but the principle is of course the same for the other EUTRA bandwidths. Data symbols are independently modulated and transmitted over a high number of closely spaced orthogonal subcarriers. In EUTRA, downlink modulation schemes QPSK, 16QAM, and 64QAM are available.

In the time domain, a guard interval may be added to each symbol to combat inter-OFDM-symbol-interference due to channel delay spread. In EUTRA, the guard interval is a cyclic prefix which is inserted prior to each OFDM symbol.

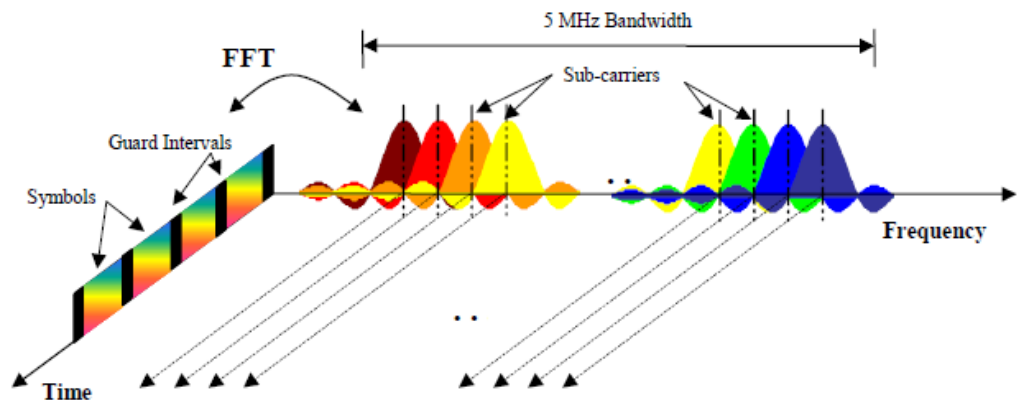

Fig. 1-1: Frequency-Time Representation of an OFDM Signal

In practice, the OFDM signal can be generated using the inverse fast Fourier transform (IFFT) digital signal processing. The IFFT converts a number N of complex data symbols used as frequency domain bins into the time domain signal. Such an N -point IFFT is illustrated in figure 1-2, where $a(mN+n)$ refers to the n^{th} subchannel modulated data symbol, during the time period $mT_u < t \leq (m+1)T_u$.

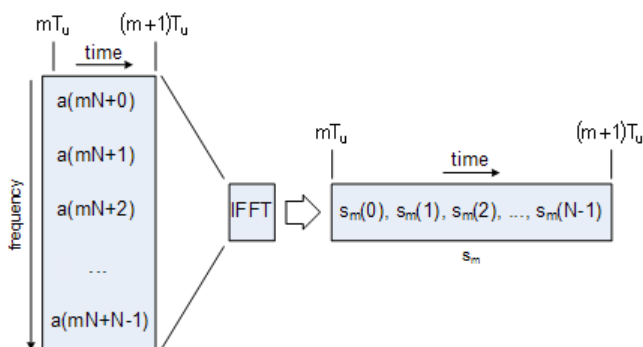

Fig. 1-2: OFDM useful symbol generation using an IFFT

The vector s_m is defined as the useful OFDM symbol. It is the time superposition of the N narrowband modulated subcarriers. Therefore, from a parallel stream of N sources of data, each one independently modulated, a waveform composed of N orthogonal subcarriers is obtained, with each subcarrier having the shape of a frequency sinc function (see figure 1-1).

figure 1-3 illustrates the mapping from a serial stream of QAM symbols to N parallel streams, used as frequency domain bins for the IFFT. The N -point time domain blocks obtained from the IFFT are then serialized to create a time domain signal. Not shown in figure 1-3 is the process of cyclic prefix insertion.

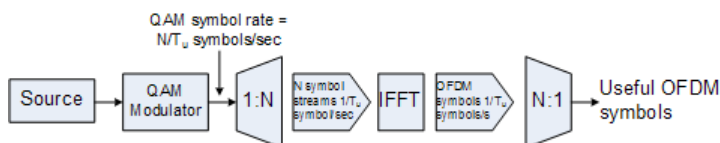

Fig. 1-3: OFDM Signal Generation Chain

In contrast to an OFDM transmission scheme, OFDMA allows the access of multiple users on the available bandwidth. Each user is assigned a specific time-frequency resource. As a fundamental principle of EUTRA, the data channels are shared channels, i.e. for each transmission time interval of 1 ms, a new scheduling decision is taken regarding which users are assigned to which time/frequency resources during this transmission time interval.

1.2.2 OFDMA Parameterization

A generic frame structure is defined for both EUTRA FDD and TDD modes. Additionally, an alternative frame structure is defined for the TDD mode only. The EUTRA frame structures are defined in 3GPP TS 36.211. For the generic frame structure, the 10 ms radio frame is divided into 20 equally sized slots of 0.5 ms. A subframe consists of two consecutive slots, so one radio frame contains 10 subframes. This is illustrated in figure 1-4 (T_s expresses the basic time unit corresponding to 30.72 MHz).

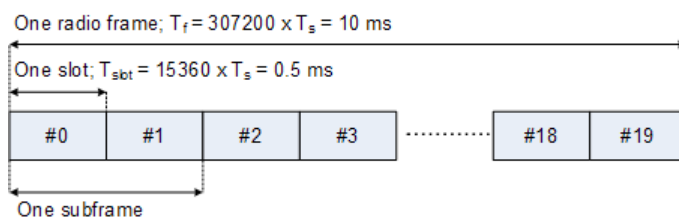

Fig. 1-4: Generic Frame Structure in EUTRA Downlink

figure 1-5 shows the structure of the downlink resource grid for the duration of one downlink slot. The available downlink bandwidth consists of $N_{\text{BW}}^{\text{DL}}$ subcarriers with a spacing of $\Delta f = 15 \text{ kHz}$. In the case of multi-cell MBMS transmission, a subcarrier spacing of $\Delta f = 7.5 \text{ kHz}$ is also possible. $N_{\text{BW}}^{\text{DL}}$ can vary in order to allow for scalable bandwidth operation up to 20 MHz. Initially, the bandwidths for LTE were explicitly defined within layer 1 specifications. Later on a bandwidth agnostic layer 1 was introduced, with $N_{\text{BW}}^{\text{DL}}$ for the different bandwidths to be specified by 3GPP RAN4 to meet performance requirements, e.g. for out-of-band emission requirements and regulatory emission limits.

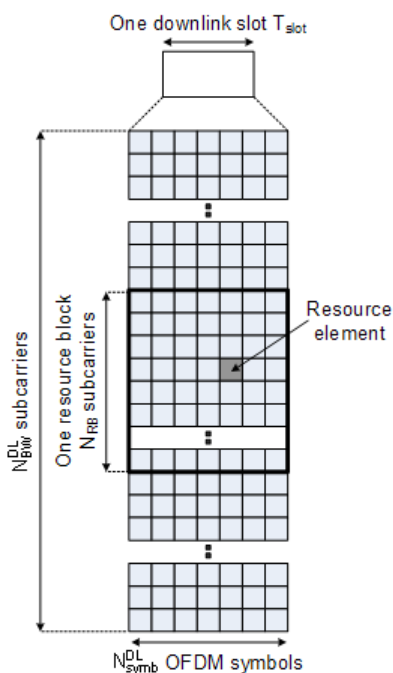

Fig. 1-5: Downlink Resource Grid

One downlink slot consists of $N_{\text{symb}}^{\text{DL}}$ OFDM symbols. To each symbol, a cyclic prefix (CP) is appended as guard time, compare figure 1-1. $N_{\text{symb}}^{\text{DL}}$ depends on the cyclic prefix length. The generic frame structure with normal cyclic prefix length contains $N_{\text{symb}}^{\text{DL}} = 7$ symbols. This translates into a cyclic prefix length of $T_{\text{CP}} \approx 5.2 \mu\text{s}$ for the first symbol and $T_{\text{CP}} \approx 4.7 \mu\text{s}$ for the remaining 6 symbols. Additionally, an extended cyclic prefix is defined in order to cover large cell scenarios with higher delay spread and MBMS transmission. The generic frame structure with extended cyclic prefix of $T_{\text{CP-E}} \approx 16.7 \mu\text{s}$ contains $N_{\text{symb}}^{\text{DL}} = 6$ OFDM symbols (subcarrier spacing 15 kHz). The generic frame

structure with extended cyclic prefix of $T_{CP-E} \approx 33.3 \mu\text{s}$ contains $N_{\text{symbol}}^{\text{DL}} = 3$ symbols (sub-carrier spacing 7.5 kHz). [table 1-1](#) gives an overview of the different parameters for the generic frame structure.

Table 1-1: Parameters for Downlink Generic Frame Structure

Configuration	Number of Symbols $N_{\text{symbol}}^{\text{DL}}$	Cyclic Prefix Length in Samples	Cyclic Prefix Length in μs
Normal cyclic prefix $\Delta f=15$ kHz	7	160 for first symbol 144 for other symbols	5.2 μs for first symbol 4.7 μs for other symbols
Extended cyclic prefix $\Delta f=15$ kHz	6	512	16.7 μs
Extended cyclic prefix $\Delta f=7.5$ kHz	3	1024	33.3 μs

1.2.3 Downlink Data Transmission

Data is allocated to the UEs in terms of resource blocks. A physical resource block consists of 12 (24) consecutive subcarriers in the frequency domain for the $\Delta f=15$ kHz ($\Delta f=7.5$ kHz) case. In the time domain, a physical resource block consists of DL N_{symbol} consecutive OFDM symbols, see [figure 1-5](#). $N_{\text{symbol}}^{\text{DL}}$ is equal to the number of OFDM symbols in a slot. The resource block size is the same for all bandwidths, therefore the number of available physical resource blocks depends on the bandwidth. Depending on the required data rate, each UE can be assigned one or more resource blocks in each transmission time interval of 1 ms. The scheduling decision is done in the base station (eNodeB). The user data is carried on the physical downlink shared channel (PDSCH). Downlink control signaling on the physical downlink control channel (PDCCH) is used to convey the scheduling decisions to individual UEs. The PDCCH is located in the first OFDM symbols of a slot.

1.2.4 Downlink Reference Signal Structure and Cell Search

The downlink reference signal structure is important for cell search, channel estimation and neighbor cell monitoring. [figure 1-6](#) shows the principle of the downlink reference signal structure for one-antenna, two-antenna, and four-antenna transmission. Specific predefined resource elements in the time-frequency domain carry the reference signal sequence. Besides first reference symbols, there may be a need for second reference symbols. The different colors in [figure 1-6](#) represent the sequences transmitted from up to four transmit antennas.

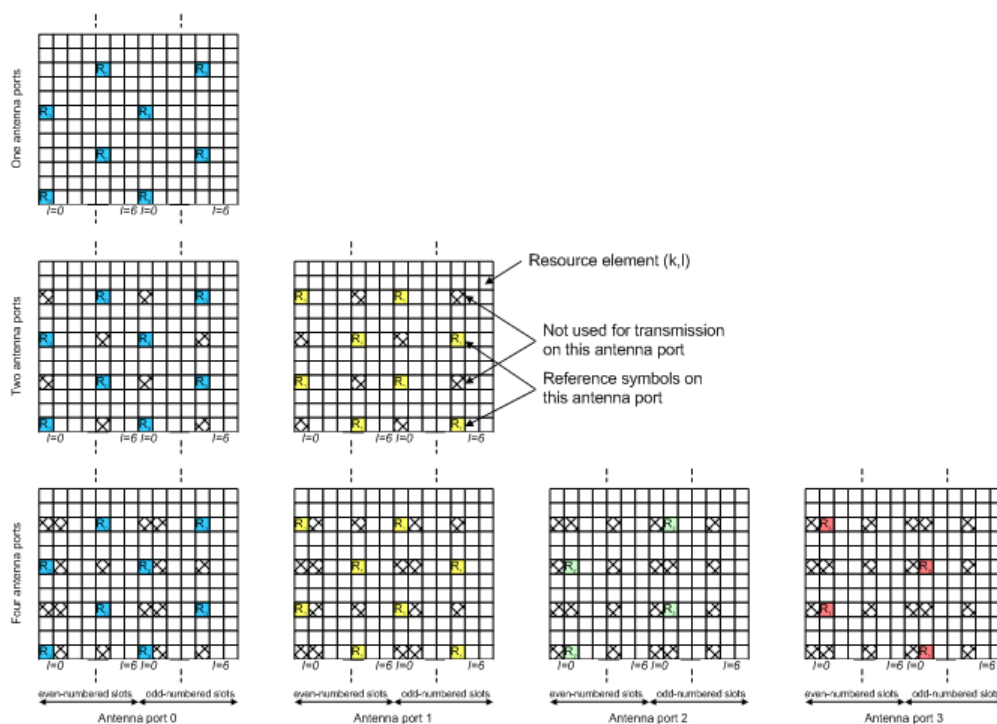

Fig. 1-6: Downlink Reference Signal Structure (Normal Cyclic Prefix)

The reference signal sequence carries the cell identity. Each reference signal sequence is generated as a symbol-by-symbol product of an orthogonal sequence r^{OS} (three of them existing) and a pseudo-random sequence r^{PRS} (170 of them existing). Each cell identity corresponds to a unique combination of one orthogonal sequence r^{OS} and one pseudo-random sequence r^{PRS} , allowing 510 different cell identities.

Frequency hopping can be applied to the downlink reference signals. The frequency hopping pattern has a period of one frame (10 ms).

During cell search, different types of information need to be identified by the handset: symbol and radio frame timing, frequency, cell identification, overall transmission bandwidth, antenna configuration, and cyclic prefix length.

Besides the reference symbols, synchronization signals are therefore needed during cell search. EUTRA uses a hierarchical cell search scheme similar to WCDMA. This means that the synchronization acquisition and the cell group identifier are obtained from different synchronization signals. Thus, a primary synchronization signal (P-SYNC) and a secondary synchronization signal (S-SYNC) are assigned a predefined structure. They are transmitted on the 72 center subcarriers (around the DC subcarrier) within the same predefined slots (twice per 10 ms) on different resource elements, see [figure 1-7](#).

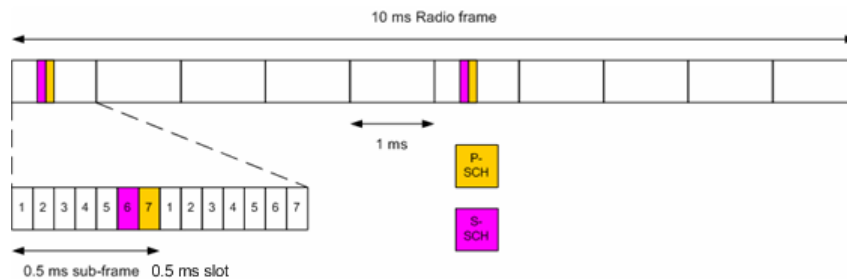

Fig. 1-7: P-SYNC and S-SYNC Structure

As additional help during cell search, a common control physical channel (CCPCH) is available which carries BCH type of information, e.g. system bandwidth. It is transmitted at predefined time instants on the 72 subcarriers centered around the DC subcarrier.

In order to enable the UE to support this cell search concept, it was agreed to have a minimum UE bandwidth reception capability of 20 MHz.

1.2.5 Downlink Physical Layer Procedures

For EUTRA, the following downlink physical layer procedures are especially important:

- **Cell search and synchronization**
See above.
- **Scheduling**
Scheduling is done in the base station (eNodeB). The downlink control channel PDCCH informs the users about their allocated time/frequency resources and the transmission formats to use. The scheduler evaluates different types of information, e.g. quality of service parameters, measurements from the UE, UE capabilities, and buffer status.
- **Link adaptation**
Link adaptation is already known from HSDPA as adaptive modulation and coding. Also in EUTRA, modulation and coding for the shared data channel is not fixed, but rather is adapted according to radio link quality. For this purpose, the UE regularly reports channel quality indications (CQI) to the eNodeB.
- **Hybrid automatic repeat request (ARQ)**
Downlink hybrid ARQ is also known from HSDPA. It is a retransmission protocol. The UE can request retransmissions of incorrectly received data packets.

1.3 References

- [1] 3GPP TS 25.913: Requirements for E-UTRA and E-UTRAN (Release 7)
- [2] 3GPP TR 25.892: Feasibility Study for Orthogonal Frequency Division Multiplexing (OFDM) for UTRAN enhancement (Release 6)
- [3] 3GPP TS 36.211 v8.3.0: Physical Channels and Modulation (Release 8)

- [4] 3GPP TS 36.300: E-UTRA and E-UTRAN; Overall Description; Stage 2 (Release 8)
- [5] 3GPP TS 22.978: All-IP Network (AIPN) feasibility study (Release 7)
- [6] 3GPP TS 25.213: Spreading and modulation (FDD)
- [7] Speth, M., Fechtel, S., Fock, G., and Meyr, H.: Optimum Receiver Design for Wireless Broad-Band Systems Using OFDM – Part I. IEEE Trans. on Commun. Vol. 47 (1999) No. 11, pp. 1668-1677.
- [8] Speth, M., Fechtel, S., Fock, G., and Meyr, H.: Optimum Receiver Design for OFDM-Based Broadband Transmission – Part II: A Case Study. IEEE Trans. on Commun. Vol. 49 (2001) No. 4, pp. 571-578.

2 Welcome

The EUTRA/LTE measurement software makes use of the I/Q capture functionality of the following spectrum and signal analyzers to enable EUTRA/LTE TX measurements conforming to the EUTRA specification.

- R&S FSQ
- R&S FSG
- R&S FSV
- R&S FSVR
- R&S FSW
- R&S RTO

This manual contains all information necessary to configure, perform and analyze such measurements.

• Licensing the Software	16
• Installing the Software	19
• Connecting the Computer to an Analyzer	19
• Application Overview	25
• Configuring the Software	28

2.1 Licensing the Software

The software provides the following general functionality.

- To capture and analyze I/Q data from an R&S®FSW, R&S®FSV, R&S®FSVR, R&S®FSQ, R&S®FSG or R&S®RTO.
- To read and analyze I/Q data from a file.

License type

You can purchase two different license types for the software.

- R&S®FS-K10xPC
This license supports software operation with and without an R&S instrument (analyzer or oscilloscope).
The software works with a connection to an analyzer but also supports the analysis of data stored in a file. This license type requires a smartcard reader (dongle).
- R&S®FSV/FSQ-K10x
This license requires a connection to an R&S®FSV, R&S®FSVR, R&S®FSQ or R&S®FSG. The license must be installed on the analyzer.

Using the smartcard reader (dongle)

Before you can use the software, you have to load the license(s) on a smartcard (if you already have one) or order a new smartcard (R&S FSPC). New license types are available as registered licenses (see below).

You can use the smart card together with the USB smart card reader (for SIM format) supplied with the software. Alternatively, you can insert the smart card (full format) in a reader that is connected to or built into your PC.

Note that support for problems with the smart card licensing can only be guaranteed if the supplied USB smart card reader (for SIM format) is used.

1. With the delivery of the R&S FSPC you got a smart card and a smart card reader.



2. Remove the smart card.



3. Insert the smart card into the reader.

If the OMNIKEY label faces upward, the smart card has to be inserted with the chip facedown and the angled corner facing away from the reader.



4. After pushing the smart card completely inside the USB smart card reader, you can use it together with the software.



When you insert the USB Smartcard reader into the PC, the drivers will be loaded. If your PC does not already have drivers installed for this reader, the hardware will not be detected and the software will not work.

In this case, install the required driver manually. On the CD, it is in the folder `\Install\USB SmartCard Reader Driver Files`, named according to the pro-

cessor architecture (OMNIKEY3x21_x86... or OMNIKEY3x21_x64). Detailed information on the file content and the download location for updated drivers can be found in the `ReadMe.txt` file in the same folder.



You may have problems locking a computer while the card is inserted, because MS Windows tries to get log-in information from the card immediately after you have locked the computer.

Solve this issue by changing a registry entry.

Either execute the registry file `DisableCAD.reg` in the same folder the USM Smartcard reader installation files are located. Or manually change the entry.

- Open the Windows Start Menu and select the "Run" item.
- Enter "regedit" in the dialog to open the system registry.
- Navigate to
`HKEY_LOCAL_MACHINE\SOFTWARE\Microsoft\Windows\CurrentVersion\policies\system.`
- Set the value of `DisableCAD` to 0.

Note that security policies may prevent you from editing the value. Contact your IT administrator if you have problems with editing the value or installing the drivers.

Ordering licenses

In case of registered licenses, the license key code is based on the serial number of the R&S FSPC smartcard. Thus, you need to know the serial number when you order a new license.

1. Start the software (without a connected dongle).
2. Press the SETUP key.
3. Press the "Dongle License Info" softkey.

The software opens the "Rohde & Schwarz License Information" dialog box.

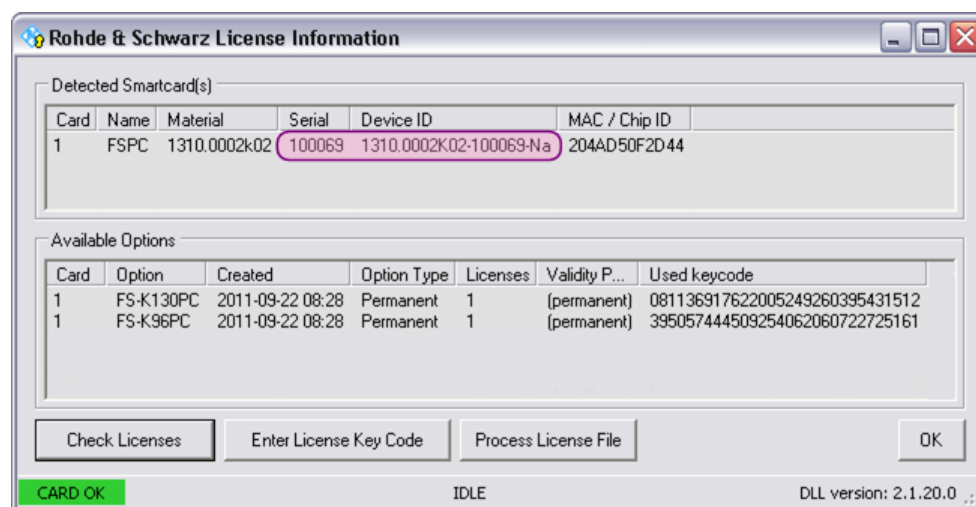

4. Connect the smartcard / dongle to the computer.

5. Press the "Check Licenses" button.
The software shows all current licenses.
The serial number which is necessary to know if you need a license is shown in the "Serial" column.
The "Device ID" also contains the serial number.
6. To enter a new license code, press the "Enter License Key Code" button.

2.2 Installing the Software

For information on the installation procedure see the release notes of the software.

2.3 Connecting the Computer to an Analyzer

In order to be able to communicate with an analyzer (R&S FSQ, R&S FSG, R&S FSV, R&S FSVR or R&S FSW) or oscilloscope (R&S RTO family), you have to connect it to a computer. You can use the IEEE bus (GPIB) or a local area network (LAN).

Requirements

To be able to capture I/Q data, you need one of the signal analyzers or oscilloscopes mentioned above.

If you are using an R&S FSQ, you must

- use firmware 3.65 or higher to be able to establish a connection via TCP/IP or
- install the RSIB passport driver on the computer.
The driver is available for download at <http://www.rohde-schwarz.com/appnote/1EF47>

To establish a connection, you also have to determine the network address of the analyzer and set it up in the LTE software.

2.3.1 Instrument Configuration

The functionality necessary to establish the connection to the test equipment is part of the "Analyzer Config / MIMO Setup" tab of the "General Settings" dialog box.

The software supports simultaneous connections to several analyzers or oscilloscopes. Using a combination of analyzers and oscilloscopes is also possible. The software automatically detects if you have connected an analyzer or an oscilloscope. On the whole, you can perform measurement on up to eight input channels. Each input channel captures one I/Q data stream.

If you use a spectrum or signal analyzer, one input channel corresponds to one instrument's RF input. Thus, the required number of analyzers depends on the number of I/Q

data streams you want to measure. The analyzers have to be connected to each other with one analyzer controlling the other instruments by providing the trigger.

If you use an oscilloscope, the number of required instruments depends on the number of channels available on the oscilloscope.

- [General Instrument Configuration](#).....20
- [Instrument Connection Configuration](#).....21

2.3.1.1 General Instrument Configuration

The general analyzer or oscilloscope configuration determines the general MIMO setup. The purpose of the general MIMO setup is to assign an analyzer or oscilloscope channel to a particular I/Q data stream.

For successful measurements, you have to configure each instrument individually in the "Analyzer Configuration" table.

The number of table rows depends on the number of input channels you have selected.

Analyzer Configuration			
Input Channel	VISA RSC	Number of Channels	Analyzer Input Channel
1 (Master)	LOCALHOST	3	1
2			2
3			3
4		1	1

Input Channel

Shows the number of the analyzer in the test setup or the channel number of an oscilloscope.

If you are using several instruments, the first input channel always represents the controlling (master) instrument.

VISA RSC

Opens a dialog box to configure the instrument connection in the network (see [chapter 2.3.1.2, "Instrument Connection Configuration"](#), on page 21).

If you perform MIMO measurements with several instruments, you have to establish a network connection for each instrument.

Number of Channels

Defines the number of channels of an oscilloscope that you want to use.

The number of instruments to configure is reduced if you use an instrument with more than one channel. The software also adjusts the contents of the "Analyzer Input Channel".

If you perform the measurement with one or more signal analyzers (for example R&S FSW), the number of channels has to be "1".

SCPI command:

`CONFigure:ACONfig<instrument>:NCHannels` on page 191

Analyzer Input Channel

Assigns one of the I/Q data streams (input channel) to a particular oscilloscope channel.

The "Analyzer Input Channel" has no effect if you use only instruments that have a single input channel.

SCPI command:

`CONFigure:ACONfig<instrument>:ICSequence` on page 191

2.3.1.2 Instrument Connection Configuration

The "Instrument Connection Configuration" dialog box contains functionality that is necessary to successfully establish a connection in a network of analyzers. The dialog box contains several elements.

Interface Type	Number	IP Address or Computer Name	Subsystem
LAN (VXI-11)	0	LOCALHOST	INSTR

VISA RSC: TCPIP::LOCALHOST

Test Connection

Cancel OK

Interface Type

Selects the type of interface you want to use. You have to connect the analyzer or oscilloscope via LAN interface or the IEEE bus (GPIB).

Number

Selects the number of the interface if the PC has more than one interfaces (e.g. several LAN cards).

Address

Defines the address of the instrument. The type of content depends on the interface type.

- **GPIB Address**
Primary GPIB address of the analyzer. Possible values are in the range from 0 to 31. The default GPIB address for an R&S instruments is 20.
Available for IEEE bus systems using the IEEE 488 protocol. The interface type is GPIB.
- **IP Address or Computer Name**
Name or host address (TCP/IP) of the computer.

Available for LAN bus systems using either the VXI-11 protocol or a Rohde&Schwarz specific protocol (RSIB). The interface type is either LAN (VXI-11) or LAN (RSIB).

Contact your local IT support for information on free IP addresses.

- The RSIB protocol is supported by all firmware version of the R&S analyzers and oscilloscopes.
- The VXI-11 protocol is supported as of R&S FSQ firmware version 3.65 and by all firmware version of the R&S FSV(R), R&S FSG and oscilloscopes.
- Complete VISA Resource String
Allows you to enter the complete VISA resource string manually. A VISA string is made up out of the elements mentioned above, separated by double colons (::), e.g. GPIB::20::INSTR.
Available for interface type "Free Entry".

Subsystem

Shows the subsystem in use. Typically you do not have to change the subsystem.

VISA RSC

Shows or defines the complete VISA resource string.

SCPI command:

`CONFigure:ACONfig<instrument>:ADDRESS` on page 190

Test Connection

Button that tests the connection.

If the connection has been established successfully, the software returns a PASSED message. If not, it shows a FAILED message.

2.3.2 Figuring Out IP Addresses

Each of the supported instruments logs its network connection information in a different place. Find instructions on how to find out the necessary information below.

2.3.2.1 Figuring Out the Address of an R&S FSQ or R&S FSG

Follow these steps to figure out GPIB or IP address of an R&S FSQ or R&S FSG.

Figuring Out the GPIB address

1. Press the SETUP key.
2. Press the "General Setup" softkey.
3. Press the "GPIB" softkey.

The R&S FSQ / FSG opens a dialog box that shows its current GPIB address.

Figuring Out the IP address

1. Press the SETUP key.
2. Press the "General Setup" softkey.
3. Press the "Configure Network" softkey.
4. Press the "Configure Network" softkey.
The MS Windows "Network Connections" dialog box opens.
5. Select the "Local Area Connection" item.
The "Local Area Connection Status" dialog box opens.
6. Select the "Support" tab.
The "Support" tab shows the current TCP/IP information of the R&S FSQ.

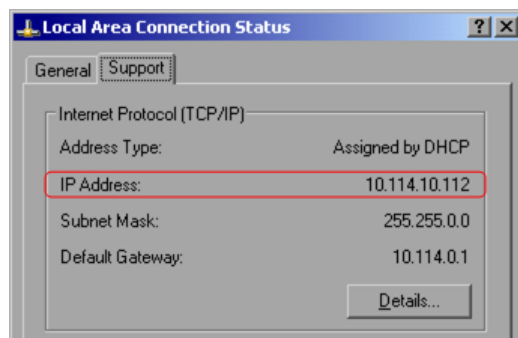

2.3.2.2 Figuring Out the Address of an R&S FSV or R&S FSVR

Follow these steps to figure out the GPIB or IP address of an R&S FSV or R&S FSVR.

Figuring Out the GPIB address

1. Press the SETUP key.
2. Press the "General Setup" softkey.
3. Press the "GPIB" softkey.
4. Press the "GPIB Address" softkey.
The R&S FSV(R) opens a dialog box that shows its current GPIB address.

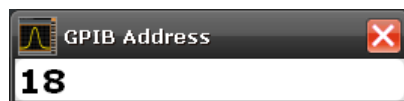

Figuring Out the IP address

1. Press the SETUP key.
2. Press the "General Setup" softkey.

3. Press the "Network Address" softkey.
4. Press the "IP Address" softkey.

The R&S FSV(R) opens a dialog box that contains information about the LAN connection.

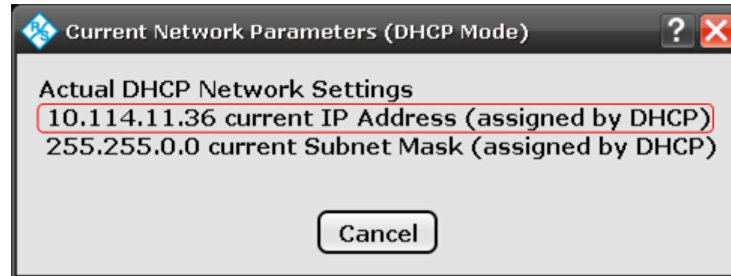

2.3.2.3 Figuring Out the Address of an R&S FSW

Follow these steps to figure out the GPIB or IP address of an R&S FSW.

Figuring Out the GPIB address

1. Press the SETUP key.
2. Press the "Network + Remote" softkey.

The R&S FSW opens the "Network & Remote" dialog box.

3. Select the "GPIB" tab.

The R&S FSW shows information about the GPIB connection, including the GPIB address.

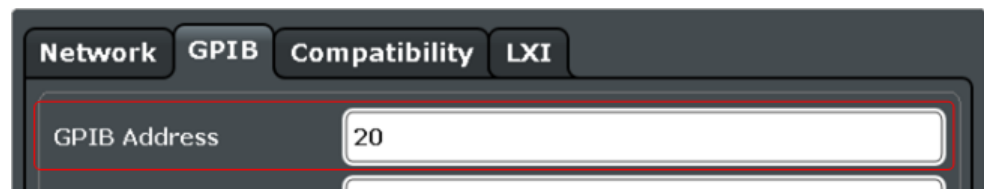

Figuring Out the IP address

1. Press the SETUP key.
2. Press the "Network + Remote" softkey.

The R&S FSW opens the "Network & Remote" dialog box and shows its current IP address in the corresponding field.

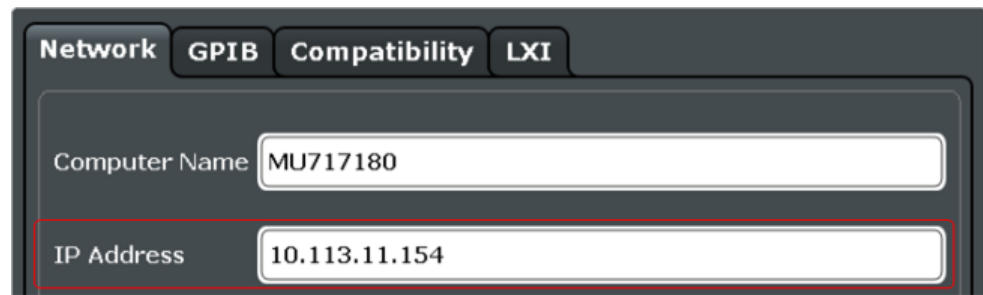

2.3.2.4 Figuring Out the Address of an R&S RTO

Follow these steps to figure out the network address of an R&S RTO.

- ▶ Press the SETUP key.

The R&S RTO opens a dialog box that contains general information about the system.

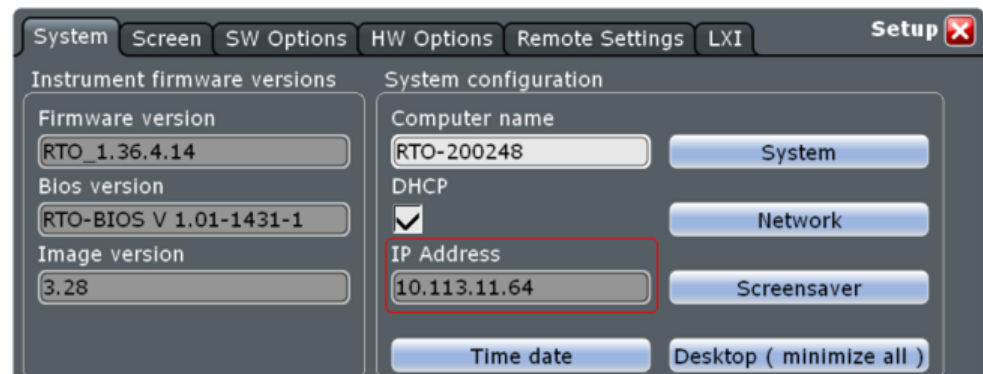

2.4 Application Overview

Starting the application

To start the software, use either the shortcut on the computer desktop or the entry in the Microsoft Windows Start menu.



If you run the software on an analyzer, access the software via the "Mode" menu.

- ▶ Press the MODE key and select "EUTRA/LTE".

Presetting the software

When you first start the software, all settings are in their default state. After you have changed any parameter, you can restore the default state with the PRESET key.

Note that using the preset function also presets an analyzer if one is connected and you capture the data from the hardware.

[CONFigure:PRESet](#) on page 226

Using the preset if the software has been installed on an R&S FSQ, R&S FSG, R&S FSV, R&S FSVR or R&S FSW presets the software and the analyzer and exits the LTE software.

SCPI command:

```
*RST
```

Elements and layout of the user interface

The user interface of the LTE measurement application is made up of several elements.

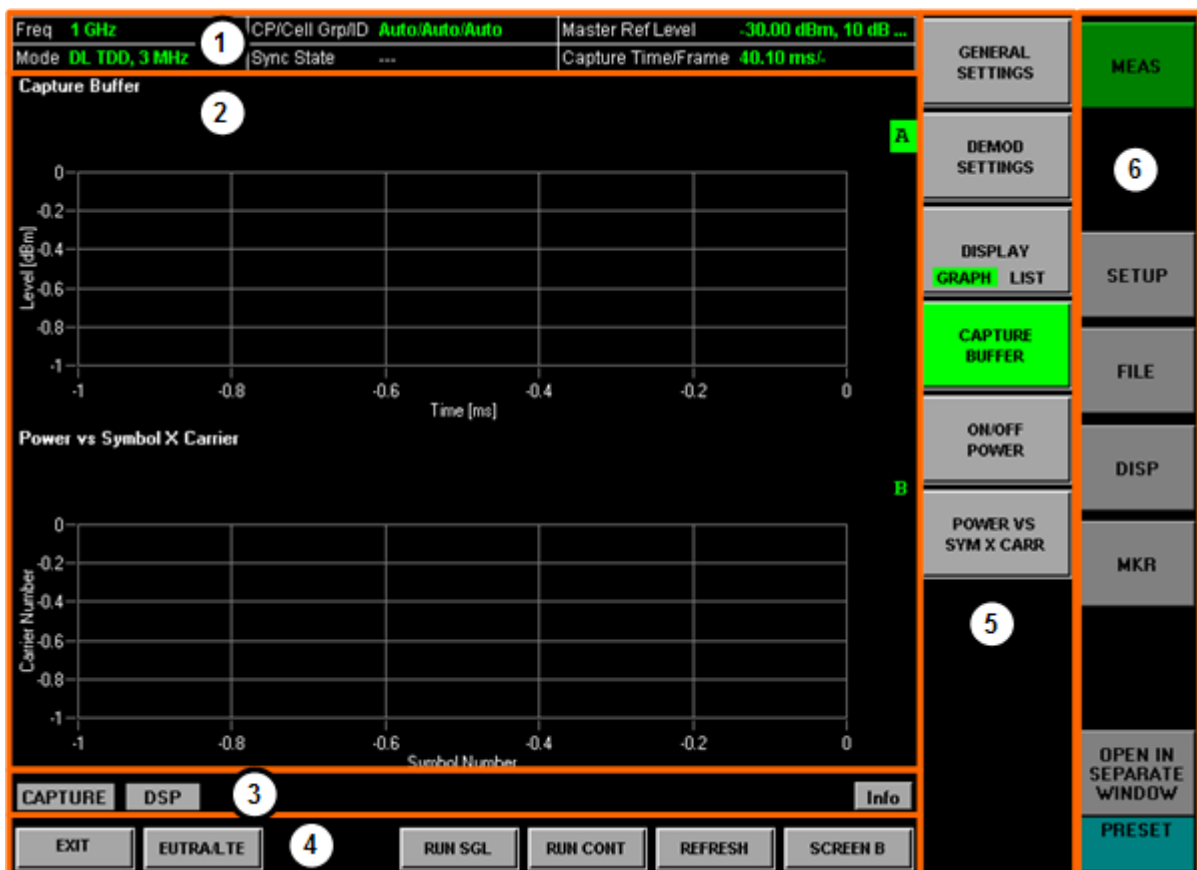

- 1 = Header table. The header table shows basic information like measurement frequency or sync state.
- 2 = Diagram area. The diagram area contains the measurement results. You can display it in full screen or split screen mode. The result display is separated in a header that shows the title etc. and the diagram area that show the actual results.
- 3 = Status bar. The status bar contains information about the current status of the measurement and the software.
- 4 = Hotkeys. Hotkeys contain functionality to control the measurement process.
- 5 = Softkeys. Softkeys contain functionality to configure and select measurement functions.
- 6 = Hardkeys. Hardkeys open new softkey menus.

The status bar

The status bar is located at the bottom of the display. It shows the current measurement status and its progress in a running measurement. The status bar also shows warning and error messages. Error messages are generally highlighted.

Display of measurement settings

The header table above the result displays shows information on hardware and measurement settings.

Freq --- (File)	CP/Cell Grp/ID Auto/Auto/Auto	Master Ref Level (0 dB)
Mode DL TDD, 3 MHz	Sync State ---	Capture Time/Frame 40.10 ms/

The header table includes the following information

- **Freq**
The analyzer RF frequency.
- **Mode**
Link direction, duplexing, cyclic prefix and maximum number of physical resource blocks (PRBs) / signal bandwidth.
- **CP/Cell Grp/ID**
Shows the cell identity information.
- **Sync State**
The following synchronization states may occur:
 - **OK** The synchronization was successful.
 - **FAIL (C)** The cyclic prefix correlation failed.
 - **FAIL (P)** The P-SYNC correlation failed.
 - **FAIL (S)** The S-SYNC correlation failed.
 Any combination of C, P and S may occur.
 SCPI Command:
[\[SENSe\] :SYNC \[:STATe\] ?](#) on page 150
- **Master Ref Level**
Shows the reference level of the master analyzer.
- **Capture Time/Frame**
Shows the capture length in ms.

2.5 Configuring the Software

This chapter contains information about general software functionality.

2.5.1 Configuring the Display

The "Display" menu contains functionality to improve the display and documentation of results.

- ▶ Press the DISP key.

The application features four screens (or result displays). Each of the screens may contain a different result display. The number of visible screens depends on the screen layout.

Full screen mode

In full screen mode, the application shows the contents a single screen.

- ▶ Press the "Full Screen" softkey.

If you have configured more than one result displays, these are still working in the background.

Split screen mode

In split screen mode, the application shows the contents of two screens, either screen A and screen B or screen C and screen D.

- ▶ Press the "Split Screen" softkey.

If you have configured more than two result displays, these are still working in the background.

2x2 split screen mode

In 2x2 split screen mode, the application shows the contents of four screens.

- ▶ Press the "2x2 Split Screen" softkey.



Limitations

For the Spectrum Emission Mask, ACLR, Time Alignment and On/Off Power measurements, a maximum of two screens is possible.

By default, the software shows the results in all four screens. The screens are labeled A to D to the right of the measurement diagrams. The label of the currently active screen is highlighted green (A). The currently active screen is the one settings are applied to.

Switch between the screens with the "Screen A", "Screen B", "Screen C" and "Screen D" hotkeys.

The background color of the software by default is black. Apply another color via the "Color Selection" softkey and the corresponding dialog box.

For documentation purposes the software provides a hardcopy function that lets you save the current results in one of the following formats.

- bmp
- gif
- jpeg
- png
- tiff

Use the "Hardcopy to Clipboard" function to take a screenshot.

[DISPlay\[:WINDow<n>\]:SElect](#) on page 226

2.5.2 Configuring the Software

The "Setup" menu contains various general software functions.

- ▶ Press the SETUP key to access the "Setup" menu.

Configure Analyzer Connection

Opens the "General Settings" dialog box.

For more information see ["MIMO Analyzer Configuration"](#) on page 81.

Data Source (Instr File)

Selects the general input source (an instrument or a file).

For more information see ["Selecting the Input Source"](#) on page 70.

Dongle License Info

Opens the "Rohde & Schwarz License Information" dialog box.

The dialog box contains functionality to add new (registered) licenses. For more information see [chapter 2.1, "Licensing the Software"](#), on page 16.

"Check Licenses"	Looks for all smartcards connected to the computer and returns their characteristics like the serial number of the smartcard or its device ID. Note that the smartcard has to be connected to figure out its properties.
"Enter License Key Code"	Opens an input field to manually enter a new license key code. A key code consists of 30 digits.
"Process License File"	Opens a dialog box to select a file (xml format) that contains a license. Opening that file automatically adds a new license.

Show Logging

Opens a dialog box that contains a log of all messages that the software has shown in the status bar.

Use the message log for debugging purposes in case any errors occur. You can refresh and clear the contents of the log or copy the contents of the system log to the clipboard.

- | | |
|---------------------|--|
| "Refresh" | Updates the contents of the log. |
| "Clear All" | Deletes all entries in the log. |
| "Copy to Clipboard" | Copies the contents of the log to the clipboard. |

System Info

Opens a dialog box that contains information about the system like driver versions or the utility software. You can use this information in case an analyzer does not work properly.

3 Measurements and Result Displays

The LTE measurement software features several measurements to examine and analyze different aspects of an LTE signal.

The source of the data that is processed is either a live signal or a previously recorded signal whose characteristics have been saved to a file. For more information see ["Selecting the Input Source"](#) on page 70.

In both cases, you can perform a continuous or a single measurement.

Continuous measurements capture and analyze the signal continuously and stop only after you turn it off manually.

- ▶ Press the "Run Cont" softkey to start and stop continuous measurements.

Single measurements capture and analyze the signal over a particular time span or number of frames. The measurement stops after the time has passed or the frames have been captured.

- ▶ Press the "Run Sgl" softkey to start a single measurement.

You can also repeat a measurement based on the data that has already been captured, e.g. if you want to apply different demodulation settings to the same signal.

- ▶ Press the "Refresh" softkey to measure the signal again.

This chapter provides information on all types of measurements that the LTE measurement software supports.

Note that all measurements are based on the I/Q data that is captured except the Spectrum Emission Mask and the Adjacent Channel Leakage Ratio. Those are based on a frequency sweep the analyzer performs for the measurement.

SCPI command:

`INITiate[:IMMEDIATE]` on page 149

`INITiate:REFresh` on page 149

● Numerical Results.....	32
● Measuring the Power Over Time.....	34
● Measuring the Error Vector Magnitude (EVM).....	40
● Measuring the Spectrum.....	45
● Measuring the Symbol Constellation.....	52
● Measuring Statistics.....	54
● Measuring Beamforming.....	60
● 3GPP Test Scenarios.....	66

3.1 Numerical Results

Result Summary

The Result Summary shows all relevant measurement results in numerical form, combined in one table.

► Press the "Display (List Graph)" softkey so that the "List" element turns green to view the Result Summary.

Remote command:

`DISPlay[:WINDow<n>]:TABLE` on page 148

Contents of the result summary

Result Summary		Selection Antenna: 1				
Frame Results 1/1	Min	Mean	Mean Limit	Max	Max Limit	Unit
EVM PDSCH QPSK	123,97	123,97		123,97	18,50	%
EVM PDSCH 16QAM	112,83	112,83		112,83	13,50	%
EVM PDSCH 64QAM	105,67	105,67		105,67	9,00	%
Results for Selection	Subframes ALL			Frame 1/1		
EVM All	104,65	109,30		111,83		%
EVM Phys. Channel	104,65	109,30		111,83		%
EVM Phys. Signal						%
Frequency Error	-12341,93	-5079,97		3893,56		Hz
Sampling Error	-1429,59	649,15		3092,63		ppm
IQ Offset	-197,27	-184,30		-177,51		dB
IQ Gain Imbalance	-0,23	0,05		0,40		dB
IQ Quadrature Error	-2,28	-0,82		0,99		°
RSTP	-23,99	-23,39		-22,90		dBm
OSTP	4,11	4,11		4,11		dBm
RSSI	4,11	4,11		4,11		dBm
Power	4,11	4,11		4,11		dBm
Crest Factor		7,74				dB

The table is split in two parts. The first part shows results that refer to the complete frame. For each result, the minimum, mean and maximum values are displayed. It also indicates limit check results where available. The font of 'Pass' results is green and that of 'Fail' results is red.

By default, the software checks the limits defined by the standard. You can also import customized limits. In that case the software evaluates those limits instead of the predefined ones. For more information see [chapter 7.3, "Importing and Exporting Limits"](#), on page 124.

EVM PDSCH QPSK	Shows the EVM for all QPSK-modulated resource elements of the PDSCH channel in the analyzed frame. FETCh:SUMMary:EVM:DSQP[:AVERage]? on page 153
EVM PDSCH 16QAM	Shows the EVM for all 16QAM-modulated resource elements of the PDSCH channel in the analyzed frame. FETCh:SUMMary:EVM:DSST[:AVERage]? on page 153
EVM PDSCH 64QAM	Shows the EVM for all 64QAM-modulated resource elements of the PDSCH channel in the analyzed frame. FETCh:SUMMary:EVM:DSSF[:AVERage]? on page 153

By default, all EVM results are in %. To view the EVM results in dB, change the [EVM Unit](#).

The second part of the table shows results that refer to a specific selection of the frame. The statistic is always evaluated over the subframes.

The header row of the table contains information about the selection you have made (like the subframe).

EVM All	Shows the EVM for all resource elements in the analyzed frame. FETCh:SUMMary:EVM[:ALL][:AVERage]? on page 152
EVM Phys Channel	Shows the EVM for all physical channel resource elements in the analyzed frame. A physical channel corresponds to a set of resource elements carrying information from higher layers. PDSCH, PBCH or PDCCH, for example, are physical channels. For more information see 3GPP 36.211. FETCh:SUMMary:EVM:PCHannel[:AVERage]? on page 154
EVM Phys Signal	Shows the EVM for all physical signal resource elements in the analyzed frame. The reference signal, for example, is a physical signal. For more information see 3GPP 36.211. FETCh:SUMMary:EVM:PSIGnal[:AVERage]? on page 154
Frequency Error	Shows the difference in the measured center frequency and the reference center frequency. FETCh:SUMMary:FERRor[:AVERage]? on page 154
Sampling Error	Shows the difference in measured symbol clock and reference symbol clock relative to the system sampling rate. FETCh:SUMMary:SERRor[:AVERage]? on page 157
I/Q Offset	Shows the power at spectral line 0 normalized to the total transmitted power. FETCh:SUMMary:IQOFFset[:AVERage]? on page 155
I/Q Gain Imbalance	Shows the logarithm of the gain ratio of the Q-channel to the I-channel. FETCh:SUMMary:GIMBalance[:AVERage]? on page 155
I/Q Quadrature Error	Shows the measure of the phase angle between Q-channel and I-channel deviating from the ideal 90 degrees. FETCh:SUMMary:QUADerror[:AVERage]? on page 156

RSTP	Shows the reference signal transmit power as defined in 3GPP TS 36.141. It is required for the "DL RS Power" test. It is an average power and accumulates the powers of the reference symbols within a subframe divided by the number of reference symbols within a subframe. FETCh:SUMMary:RSTP[:AVERage]? on page 157
OSTP	Shows the OFDM symbol transmit power as defined in 3GPP TS 36.141. It accumulates all subcarrier powers of the 4th OFDM symbol. The 4th (out of 14 OFDM symbols within a subframe (in case of frame type 1, normal CP length)) contains exclusively PDSCH. FETCh:SUMMary:OSTP[:AVERage]? on page 155
RSSI	Shows the Received Signal Strength Indicator. The RSSI is the complete signal power of the channel that has been measured, regardless of the origin of the signal. FETCh:SUMMary:RSSI[:AVERage]? on page 157
Power	Shows the average time domain power of the analyzed signal. FETCh:SUMMary:POWer[:AVERage]? on page 156
Crest Factor	Shows the peak-to-average power ratio of captured signal. FETCh:SUMMary:CRESt[:AVERage]? on page 152

3.2 Measuring the Power Over Time

This chapter contains information on all measurements that show the power of a signal over time.

Capture Buffer	34
On / Off Power	36
Power vs Symbol x Carrier	38
Time Alignment Error	39

Capture Buffer

The Capture Buffer result display shows the complete range of captured data for the last data capture. The x-axis represents time. The maximum value of the x-axis is equal to the [Capture Time](#). The y-axis represents the amplitude of the captured I/Q data in dBm (for RF input).

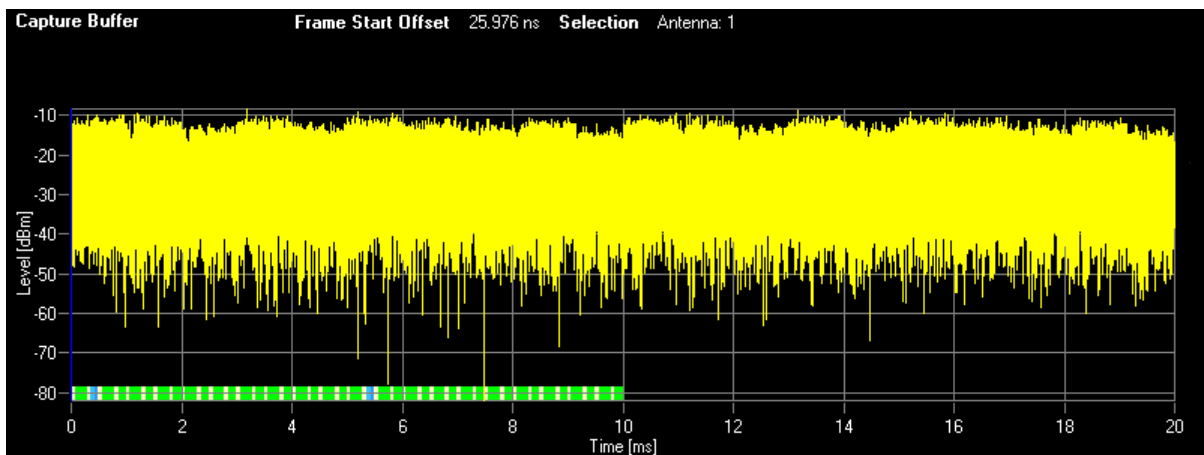





Fig. 3-1: Capture buffer without zoom

The bar at the bottom of the diagram represents the frame that is currently analyzed. Different colors indicate the OFDM symbol type.

-  Indicates the data stream.
-  Indicates the reference signal and data.
-  Indicates the P-SYNC and data.
-  Indicates the S-SYNC and data.

A blue vertical line at the beginning of the green bar in the Capture Buffer display represents the subframe start. Additionally, the diagram contains the "Start Offset" value. This value is the time difference between the subframe start and capture buffer start.

When you zoom into the diagram, you will see that the bar may be interrupted at certain positions. Each small bar indicates the useful parts of the OFDM symbol.

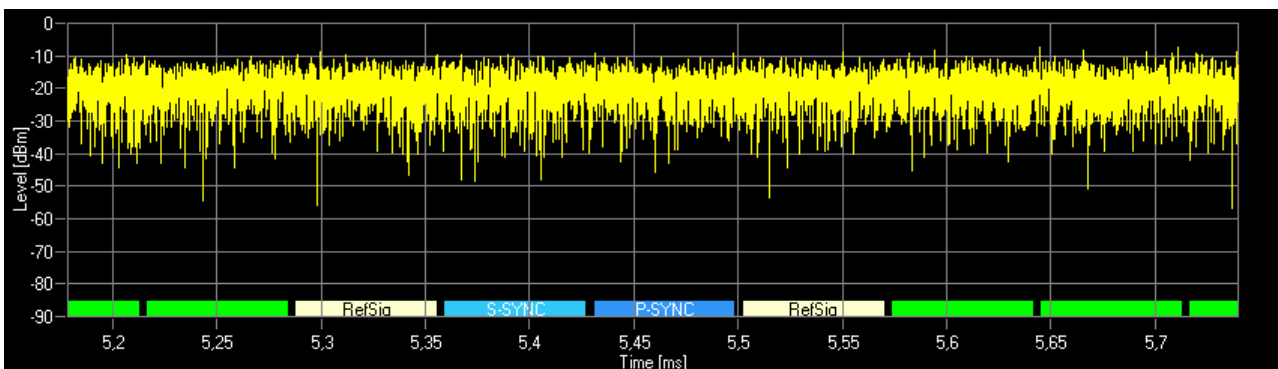

Fig. 3-2: Capture buffer after a zoom has been applied to a downlink signal

Remote command:

Selecting the result display: `CALCulate<n>:FEED 'PVT:CBUF'`

Querying results: `TRACe:DATA?`

Querying the subframe start offset: `FETCh:SUMMary:TFRame?` on page 157

On / Off Power

The On / Off Power measurement shows the characteristics of an LTE TDD signal over time.

The transition from transmission to reception is an issue in TDD systems. Therefore, the measurement is available for TDD signals.

The measurement is designed to verify if the signal intervals during which no downlink signal is transmitted (reception or "off" periods) complies with the limits defined by 3GPP. Because the transition from transmission ("on" periods) to reception has to be very fast in order to efficiently use the resources, 3GPP has also defined limits for the transient periods. The limits for these are also verified by the measurement.

Note that the measurement works only if you are using the RF input. When you start the measurement, the software records new I/Q data instead of using the data other I/Q measurements are based on.

For more information on setting up the measurement see [chapter 8.7, "Performing Transmit On/Off Power Measurements"](#), on page 140.

The result display for the On / Off Power measurement consists of numerical results and the graphic display of the signal characteristics.

Numerical results

The upper part of the result display shows the results in numerical form.

Each line in the table shows the measurement results for one "off" period.

ON/OFF Power						
Start OFF Period Limit	Stop OFF Period Limit	Time at Δ to Limit	OFF Power Abs [dBm]	OFF Power Δ to Limit	Falling Trans. Period	Rising Trans. Period
1,267 ms	4,948 ms	3,304460 ms	-80,11	5,11 dB	1,95 μ s	2,67 μ s
6,267 ms	9,948 ms	6,897558 ms	-80,14	5,14 dB	2,18 μ s	2,54 μ s

- Start OFF Period Limit
Shows the beginning of the "off" period relative to the frame start (0 seconds).
- Stop OFF Period Limit
Shows the end of the "off" period relative to the frame start (0 seconds).
The time from the start to the stop of the "off" period is the period over which the limits are checked. It corresponds to the yellow trace in the graphic result display.
- Time at Δ to Limit
Shows the trace point at which the lowest distance between trace and limit line has been detected. The result is a time relative to the frame start.
- OFF Power Abs [dBm]
Shows the absolute power of the signal at the trace point with the lowest distance to the limit line.
- OFF Power Δ to Limit
Shows the distance between the trace and the limit line of the trace point with the lowest distance to the limit line in dB.
- Falling Transition Period
Shows the length of the falling transient.
- Rising Transition Period
Shows the length of the rising transient.

Note that the beginning and end of a transition period is determined based on the "Off Power Density Limit". This limit is defined by 3GPP in TS 36.141 as the maximum allowed mean power spectral density. The length of the transient from "on" to "off" period is, for example, the distance from the detected end of the subframe to the last time that the signal power is above the measured mean power spectral density.

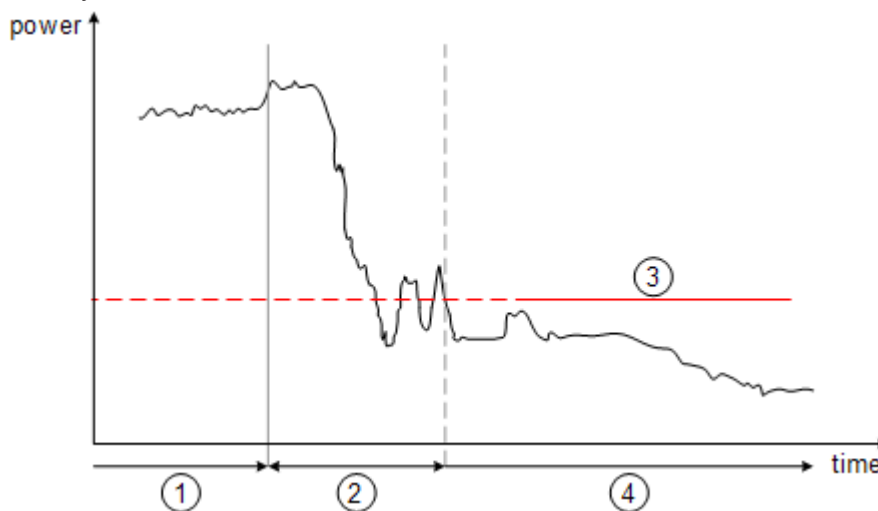

Fig. 3-3: Power profile of an TD-LTE On-to-Off transition. The transition lasts from the end of the OFF period until the signal is completely below the Off Power Density limit.

- 1 = subframe ("on" power period)
- 2 = transient (transition length)
- 3 = "off" power density limit
- 4 = "off" power period

The diagram contains an overall limit check result (Pass / Fail message). Only if all "off" periods (including the transients) comply to the limits, the overall limit check will pass.

Any results in the table that violate the limits defined by 3GPP are displayed in red.

Graphic results

The lower part of the result display shows a graphical representation of the analyzed TDD frame(s).

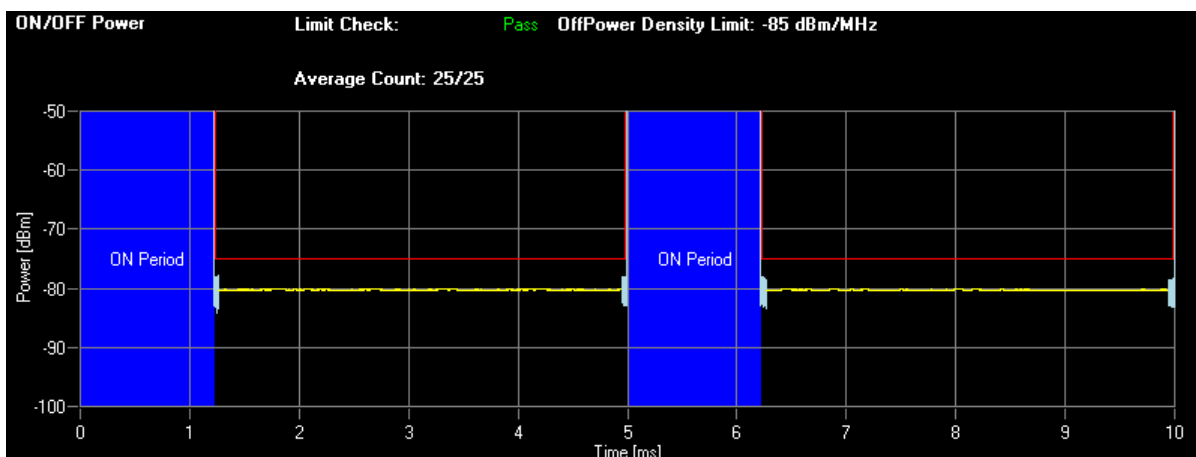

The diagram contains several elements.

- **Yellow trace**
The yellow trace represents the signal power during the "off" periods. Filtering as defined in 3GPP TS 36.141 is taken into account for the calculation of the trace.
- **Blue trace**
The blue trace represents the transition periods (falling and rising). Note that the blue trace might be visible only after zooming into the diagram because of its steep flank and small horizontal dimensions.

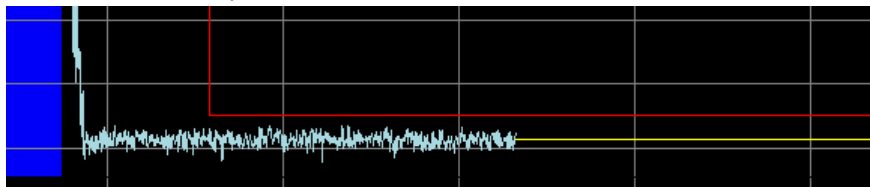

- **Blue rectangles**
The blue rectangles represent the "on" periods. Because of the overload during the "on" periods, the actual signal power is only hinted at, not shown.
- **Red lines**
Limits as defined by 3GPP.

In addition to these elements, the diagram also shows the overall limit check (see above), the average count and the limit for the mean power spectral density ("Off Power Density Limit").

Adjust Timing

If you are using an external trigger for the On / Off power measurement, you have to determine the offset of the trigger time to the time the LTE frame starts. You can do this with the "Adjust Timing" function. When the software has determined the offset, it corrects the results of the On / Off Power measurement accordingly.

Remote command:

Selecting the result display: `CALCulate<n>:FEED 'PVT:OOP'`

Querying results: `TRACe:DATA?`

Querying limit check results:

`CALCulate<n>:LIMit<k>:OOPower:OFFPower?` on page 175

`CALCulate<n>:LIMit<k>:OOPower:TRANSient?` on page 176

`[SENSe] [:LTE]:OOPower:ATIMing` on page 150

Power vs Symbol x Carrier

The Power vs Symbol x Carrier shows the power for each carrier in each symbol.

The horizontal axis represents the symbols. The vertical axis represents the carriers. Different colors in the diagram area represent the power. The color map for the power levels is provided above the diagram area.

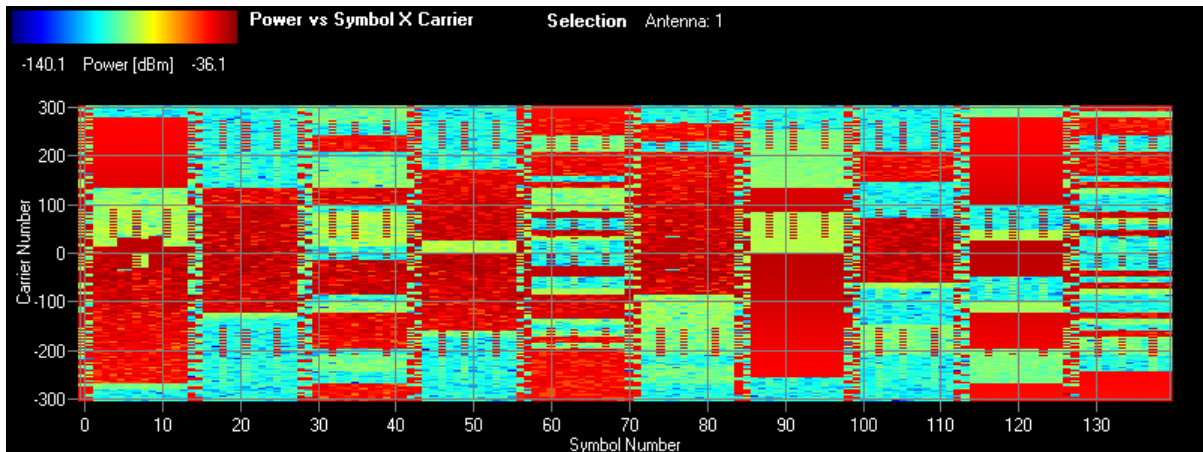

Remote command:
 Selecting the result display: `CALCulate<n>:FEED 'SPEC:PVSC'`
 Querying results: `TRACe:DATA?`

Time Alignment Error

Starts the Time Alignment Error result display.

The time alignment is an indicator of how well the transmission antennas in a MIMO system are synchronized. The Time Alignment Error is the time delay between a reference antenna (for example antenna 1) and another antenna. For more information see [chapter 8.6, "Performing Time Alignment Measurements"](#), on page 138.

The software shows the results in a table.

Each row in the table represents one antenna. The reference antenna is not shown.

For each antenna the maximum, minimum and average time delay that has been measured is shown. The minimum and maximum results are calculated only if the measurement covers more than one frame.

If you perform the measurement on a system with carrier aggregation, each row represents one antenna. The number of lines increases because of multiple carriers. The reference antenna of the main component carrier (CC1) is not shown. In case of carrier aggregation, the result display also evaluates the frequency error of the component carrier (CC2) relative to the main component carrier (CC1).

In any case, results are only displayed if the transmission power of both antennas is within 15 dB of each other. Likewise, if only one antenna transmits a signal, results will not be displayed (for example if the cabling on one antenna is faulty).

For more information on configuring this measurement see [chapter 4.1.6, "Configuring Time Alignment Measurements"](#), on page 76.

Time Alignment Error				
Reference Antenna: Antenna 1(CC1) Frequency Error to CC1: -0,05 Hz				
Component Carrier	Antenna	Min	Time Alignment Error to Antenna 1 (CC1) Mean	Max
CC1	Antenna 2	0,00 ns	0,00 ns	0,00 ns
CC2	Antenna 1	-0,07 ns	-0,07 ns	-0,07 ns
CC2	Antenna 2	-0,05 ns	-0,05 ns	-0,05 ns

You can select the reference antenna via "Antenna Selection" in the [MIMO Configuration](#).

When you perform a time alignment measurement, the software also displays the Power Spectrum result display.

Remote command:

Selecting the result display: `CALCulate<screenid>:FEED 'PVT:TAER'`

Querying results: `FETCH:TAERror[:CC<cci>]:ANTenna<antenna>[:AVERage]?` on page 158

Selecting reference antenna: `CONFigure[:LTE]:DL[:CC<cci>]:MIMO:ASElection` on page 208

Querying the frequency error: `FETCH[:CC<cci>]:SUMMary:RFERror[:AVERage]?` on page 156

3.3 Measuring the Error Vector Magnitude (EVM)

This chapter contains information on all measurements that show the error vector magnitude (EVM) of a signal.

The EVM is one of the most important indicators for the quality of a signal. For more information on EVM calculation methods refer to [chapter 8, "Measurement Basics"](#), on page 126.

EVM vs Carrier	40
EVM vs Symbol	41
EVM vs Sym x Carr	42
EVM vs RB	43
EVM vs Subframe	43
Frequency Error vs Symbol	44

EVM vs Carrier

Starts the EVM vs Carrier result display.

This result display shows the Error Vector Magnitude (EVM) of the subcarriers. With the help of a marker, you can use it as a debugging technique to identify any subcarriers whose EVM is too high.

The results are based on an average EVM that is calculated over the resource elements for each subcarrier. This average subcarrier EVM is determined for each analyzed subframe in the capture buffer.

If you analyze all subframes, the result display contains three traces.

- Average EVM
This trace shows the subcarrier EVM averaged over all subframes.
- Minimum EVM
This trace shows the lowest (average) subcarrier EVM that has been found over the analyzed subframes.
- Maximum EVM
This trace shows the highest (average) subcarrier EVM that has been found over the analyzed subframes.

If you select and analyze one subframe only, the result display contains one trace that shows the subcarrier EVM for that subframe only. Average, minimum and maximum values in that case are the same. For more information see "[Subframe Selection](#)" on page 75

The x-axis represents the center frequencies of the subcarriers. On the y-axis, the EVM is plotted either in % or in dB, depending on the [EVM Unit](#).

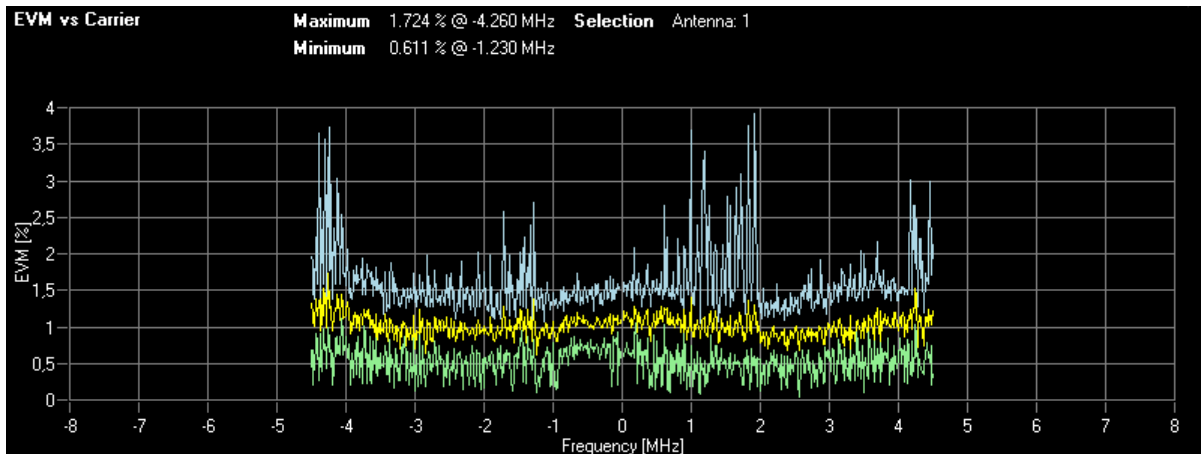

Remote command:

Selecting the result display: [CALCulate<n>:FEED 'EVM:EVCA'](#)

Querying results: [TRACe:DATA?](#)

EVM vs Symbol

Starts the EVM vs Symbol result display.

This result display shows the Error Vector Magnitude (EVM) of the OFDM symbols. You can use it as a debugging technique to identify any symbols whose EVM is too high.

The results are based on an average EVM that is calculated over all subcarriers that are part of a particular OFDM symbol. This average OFDM symbol EVM is determined for all OFDM symbols in each analyzed subframe.

If you analyze all subframes, the result display contains three traces.

- Average EVM
This trace shows the OFDM symbol EVM averaged over all subframes.
- Minimum EVM
This trace shows the lowest (average) OFDM symbol EVM that has been found over the analyzed subframes.
- Maximum EVM
This trace shows the highest (average) OFDM symbol EVM that has been found over the analyzed subframes.

If you select and analyze one subframe only, the result display contains one trace that shows the OFDM symbol EVM for that subframe only. Average, minimum and maximum values in that case are the same. For more information see "[Subframe Selection](#)" on page 75

Measuring the Error Vector Magnitude (EVM)

The x-axis represents the OFDM symbols, with each symbol represented by a dot on the line. The number of displayed symbols depends on the Subframe Selection and the length of the cyclic prefix. Any missing connections from one dot to another mean that the software could not determine the EVM for that symbol. In case of TDD signals, the result display does not show OFDM symbols that are not part of the measured link direction.

On the y-axis, the EVM is plotted either in % or in dB, depending on the [EVM Unit](#).

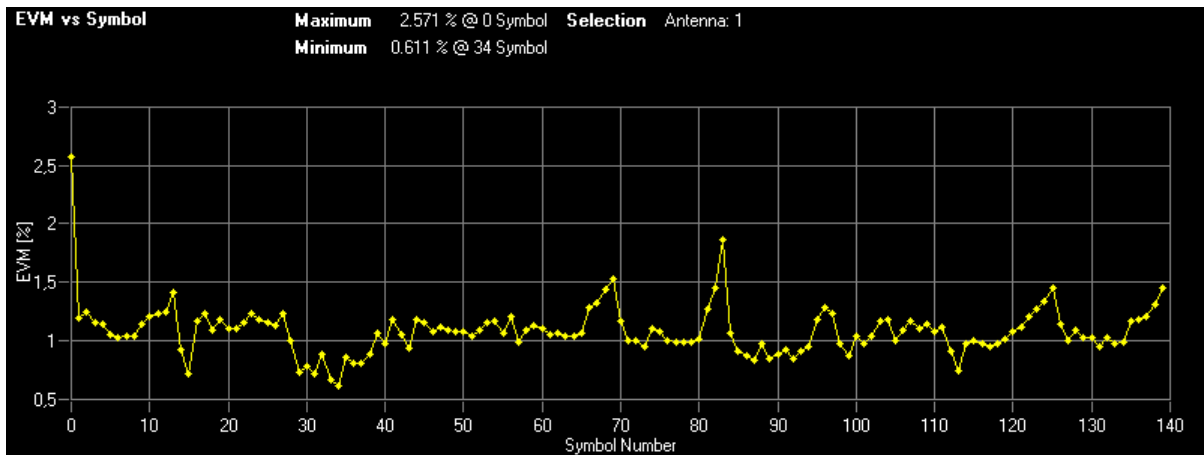

Remote command:

Selecting the result display: [CALCulate<n>:FEED 'EVM:EVSY'](#)

Querying results: [TRACe:DATA?](#)

EVM vs Sym x Carr

The EVM vs Symbol x Carrier shows the EVM for each carrier in each symbol.

The horizontal axis represents the symbols. The vertical axis represents the carriers. Different colors in the diagram area represent the EVM. The color map for the power levels is provided above the diagram area.

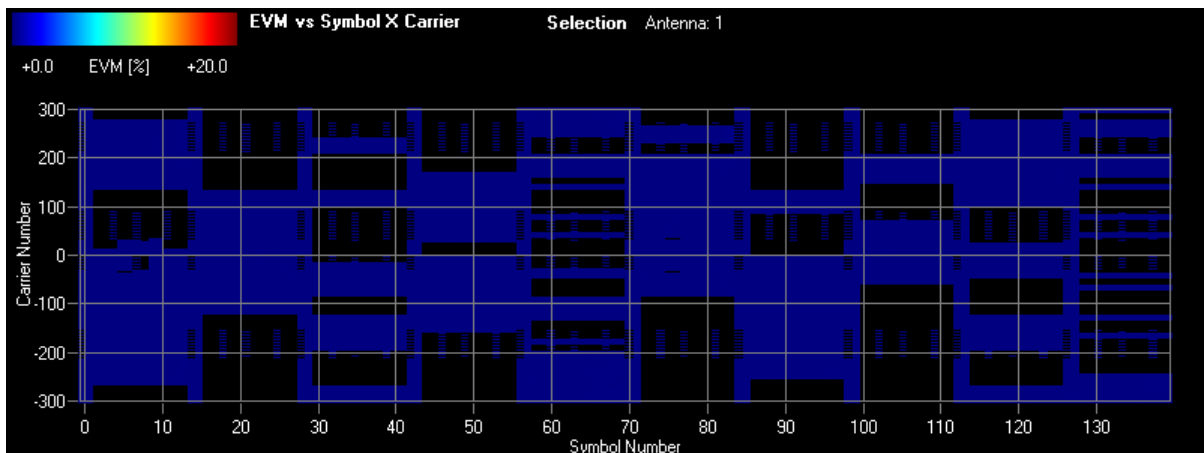

Remote command:

Selecting the result display: [CALCulate<n>:FEED 'EVM:EVSC'](#)

Querying results: [TRACe:DATA?](#)

EVM vs RB

Starts the EVM vs RB result display.

This result display shows the Error Vector Magnitude (EVM) for all resource blocks that can be occupied by the PDSCH.

The results are based on an average EVM that is calculated over all resource elements in the resource block. This average resource block EVM is determined for each analyzed subframe.

If you analyze all subframes, the result display contains three traces.

- Average EVM
This trace shows the resource block EVM averaged over all subframes.
- Minimum EVM
This trace shows the lowest (average) resource block EVM that has been found over the analyzed subframes.
- Maximum EVM
This trace shows the highest (average) resource block EVM that has been found over the analyzed subframes.

If you select and analyze one subframe only, the result display contains one trace that shows the resource block EVM for that subframe only. Average, minimum and maximum values in that case are the same. For more information see "[Subframe Selection](#)" on page 75

The x-axis represents the PDSCH resource blocks. On the y-axis, the EVM is plotted either in % or in dB, depending on the [EVM Unit](#).

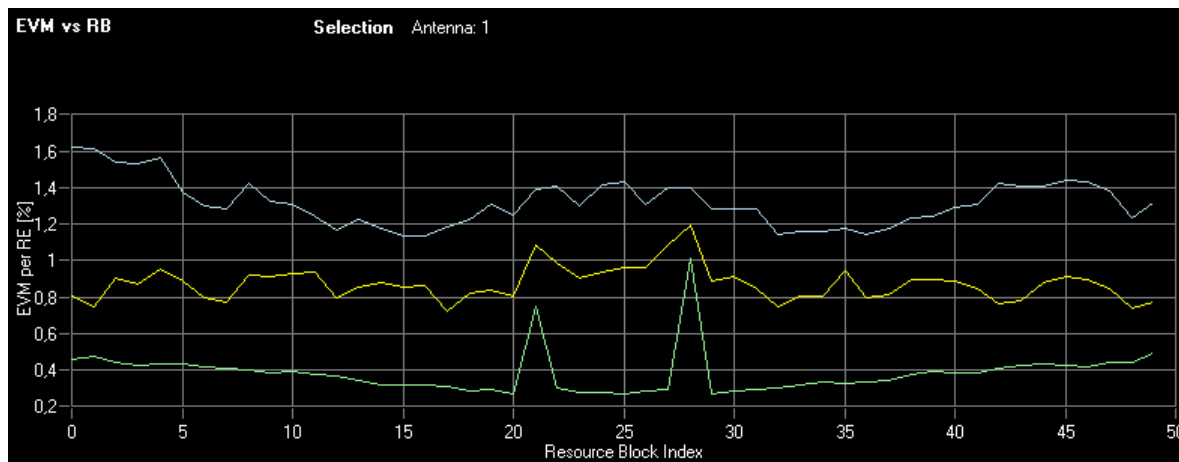

Remote command:

Selecting the result display: `CALCulate<n>:FEED 'EVM:EVRP'`

Querying results: `TRACe:DATA?`

EVM vs Subframe

Starts the EVM vs Subframe result display.

This result display shows the Error Vector Magnitude (EVM) for each subframe. You can use it as a debugging technique to identify a subframe whose EVM is too high.

The result is an average over all subcarriers and symbols of a specific subframe.

The x-axis represents the subframes, with the number of displayed subframes being 10.

On the y-axis, the EVM is plotted either in % or in dB, depending on the [EVM Unit](#).

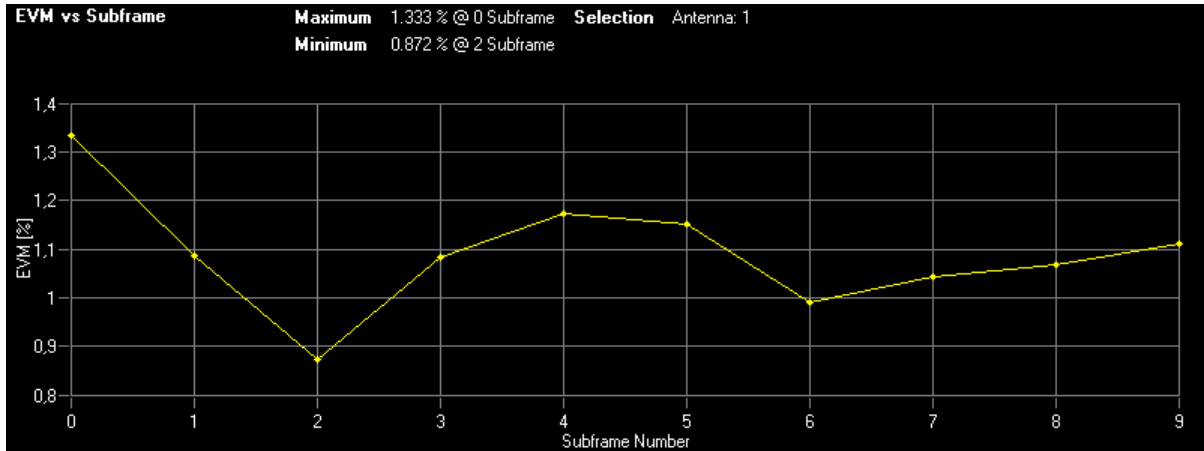

Remote command:

Selecting the result display: `CALCulate<n>:FEED 'EVM:EVSU'`

Querying results: `TRACe:DATA?`

Frequency Error vs Symbol

Starts the Frequency Error vs Symbol result display.

This result display shows the Frequency Error on symbol level. You can use it as a debugging technique to identify any frequency errors within symbols.

The result is an average over all subcarriers.

The x-axis represents the OFDM symbols. The number of displayed symbols depends on the Subframe Selection and the length of the cyclic prefix. On the y-axis, the frequency error is plotted in Hz.

Note that the variance of the measurement results in this result display may be much higher compared to the frequency error display in the [Result Summary](#), depending on the PDSCH and control channel configuration. The potential difference is caused by the number of available resource elements for the measurement on symbol level.

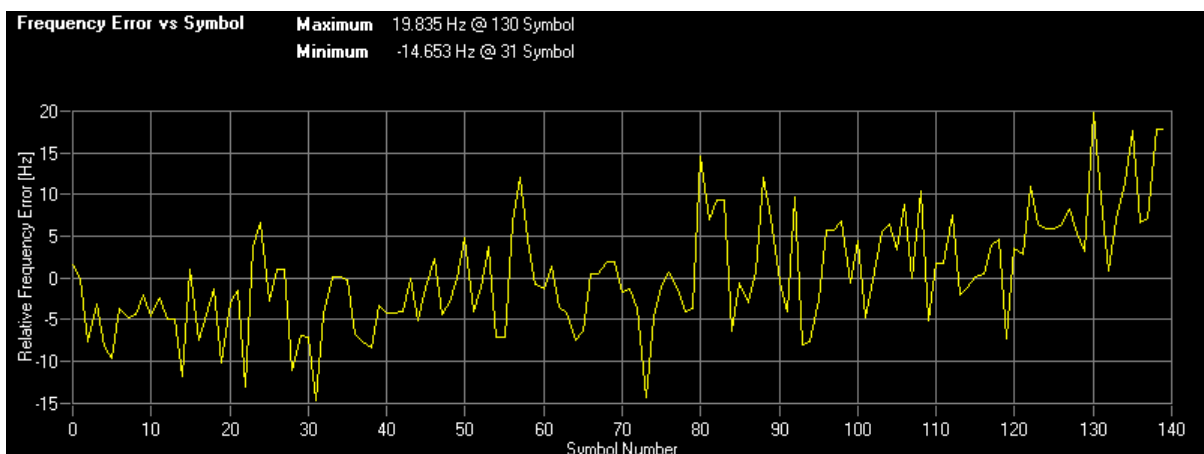

Remote command:

Selecting the result display: `CALCulate<n>:FEED 'EVM:FEVS'`

Querying results: `TRACe:DATA?`

3.4 Measuring the Spectrum

This chapter contains information on all measurements that show the power of a signal in the frequency domain.

In addition to the I/Q measurements, spectrum measurements also include two frequency sweep measurements, the Spectrum Emission Mask and the Adjacent Channel Leakage Ratio.

3.4.1 Frequency Sweep Measurements

The Spectrum Emission Mask (SEM) and Adjacent Channel Leakage Ratio (ACLR) measurements are the only frequency sweep measurements available for the EUTRA/LTE measurement software. They do not use the I/Q data all other measurements use. Instead those measurements sweep the frequency spectrum every time you run a new measurement. Therefore it is not possible to run an I/Q measurement and then view the results in the frequency sweep measurements and vice-versa. Also because each of the frequency sweep measurements uses different settings to obtain signal data it is not possible to run a frequency sweep measurement and view the results in another frequency sweep measurement.

Frequency sweep measurements are available if RF input is selected.

Note that unwanted emissions measurements (for example the ACLR) are not supported for measurements with an oscilloscope.

Spectrum Mask.....	45
ACLR.....	47

Spectrum Mask

Starts the Spectrum Emission Mask (SEM) result display.

The Spectrum Emission Mask measurement shows the quality of the measured signal by comparing the power values in the frequency range near the carrier against a spectral mask that is defined by the 3GPP specifications. In this way, you can test the performance of the DUT and identify the emissions and their distance to the limit.

In the diagram, the SEM is represented by a red line. If any measured power levels are above that limit line, the test fails. If all power levels are inside the specified limits, the test is passed. The software labels the limit line to indicate whether the limit check has passed or failed.

The x-axis represents the frequency with a frequency span that relates to the specified EUTRA/LTE channel bandwidths. On the y-axis, the power is plotted in dBm.

The result display also contains some numerical results for the SEM measurement, for example the total signal power or the limit check result.

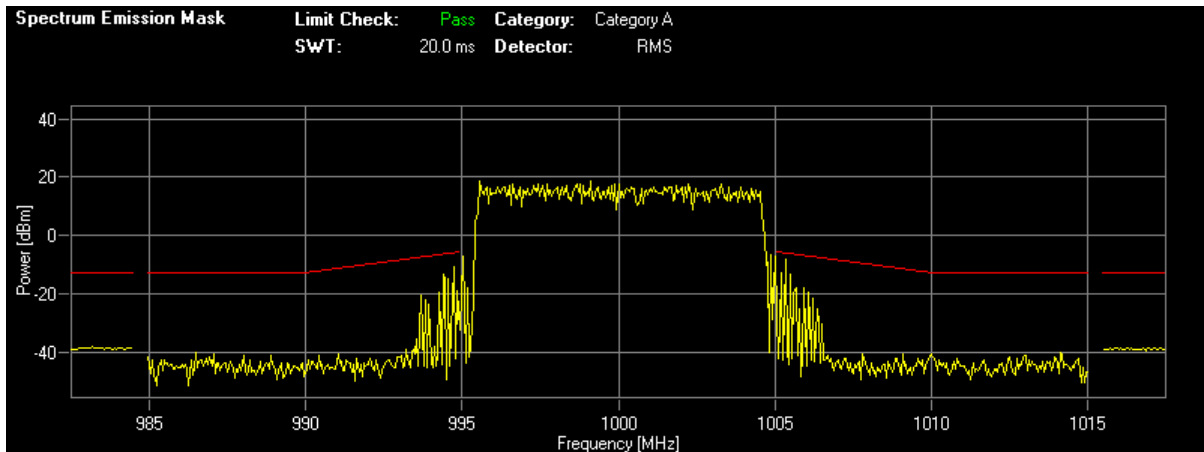

A table above the result display contains the numerical values for the limit check at each check point:

- **Start / Stop Freq Rel**
Shows the start and stop frequency of each section of the Spectrum Mask relative to the center frequency.
- **RBW**
Shows the resolution bandwidth of each section of the Spectrum Mask
- **Freq at Δ to Limit**
Shows the absolute frequency whose power measurement being closest to the limit line for the corresponding frequency segment.
- **Power Abs**
Shows the absolute measured power of the frequency whose power is closest to the limit. The software evaluates this value for each frequency segment.
- **Power Rel**
Shows the distance from the measured power to the limit line at the frequency whose power is closest to the limit. The software evaluates this value for each frequency segment.
- **Δ to Limit**
Shows the minimal distance of the tolerance limit to the SEM trace for the corresponding frequency segment. Negative distances indicate the trace is below the tolerance limit, positive distances indicate the trace is above the tolerance limit.

Spectrum Emission Mask List

Start Freq. Rel.	Stop Freq. Rel.	RBW	Freq. at Δ to Limit	Pwr Abs [dBm]	Pwr Rel [dB]	Δ to Limit [dB]
-17,50 MHz	-15,50 MHz	1,00 MHz	0,983173100 GHz	-38,26	-72,55	-25,26
-15,05 MHz	-10,05 MHz	0,10 MHz	0,986482400 GHz	-40,14	-74,44	-27,64
-10,05 MHz	-5,05 MHz	0,10 MHz	0,994727600 GHz	-10,81	-45,10	-5,00
5,05 MHz	10,05 MHz	0,10 MHz	1,005329000 GHz	-8,12	-42,41	-2,23
10,05 MHz	15,05 MHz	0,10 MHz	1,014135000 GHz	-40,14	-74,43	-27,64
15,50 MHz	17,50 MHz	1,00 MHz	1,016266000 GHz	-38,40	-72,70	-25,40

Remote command:

Selecting the result display: **CALCulate**<n>:FEED 'SPEC:SEM'

Querying results: **TRACe:DATA?**

ACLR

Starts the Adjacent Channel Leakage Ratio (ACLR) measurement.

The ACLR measurement analyzes the power of the transmission (TX) channel and the power of the two neighboring channels (adjacent channels) to the left and right of the TX channel. Thus, the ACLR measurement provides information about the power in the adjacent channels as well as the leakage into these adjacent channels.

The software shows two traces, a yellow one (T1) and a green one (T2). The yellow trace is the representation of the signal data measured with a resolution bandwidth (RBW) of 1 MHz. The green trace is the data measured with a RBW of 100 kHz.

The x-axis represents the frequency with a frequency span that relates to the specified EUTRA/LTE channel and adjacent channel bandwidths. On the y-axis, the power is plotted in dBm.

By default the ACLR settings are based on the selected LTE Channel Bandwidth. You can change the assumed adjacent channel carrier type and the [Noise Correction](#).

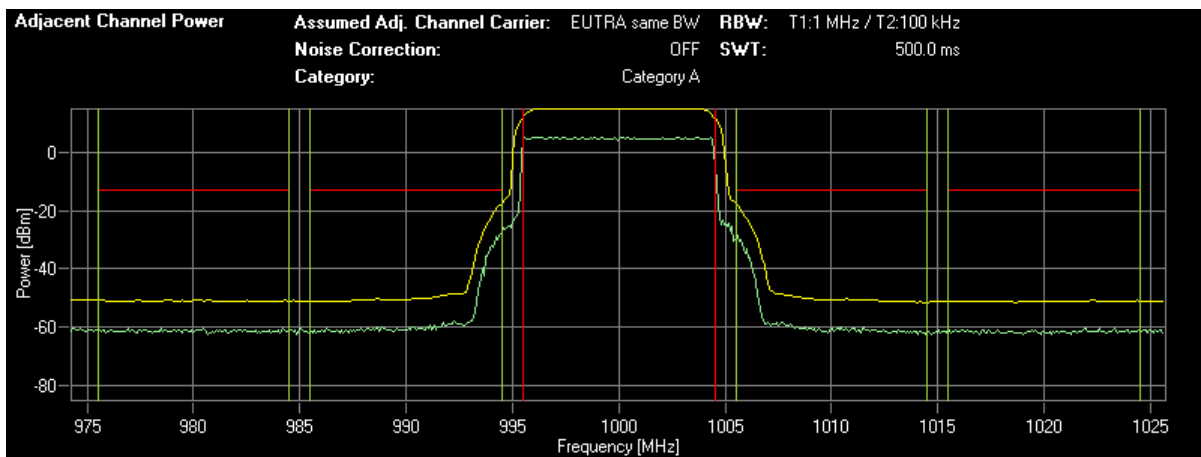

The software provides a relative and an absolute ACLR measurement mode that you can select with the "ACLR (REL ABS)" softkey.

- In case of the relative measurement mode, the power for the TX channel is an absolute value in dBm. The power of the adjacent channels are values relative to the power of the TX channel.
- In case of the absolute measurement mode, the power for both TX and adjacent channels are absolute values in dBm.

In addition, the ACLR measurement results are also tested against the limits defined by 3GPP. In the diagram, the limits are represented by horizontal red lines.

The software performs two types of limit check.

- The limit check for the limits defined for the channel power of each adjacent channel.
The channel power limit check is based on the green trace.
- The minimum distance of the actual power to the limit line in each channel. In addition to the distance (in dB), the software also shows the frequency at which the minimum distance has been measured in each channel.
The distance to the limit line is measured for the yellow trace.

The limit check result evaluates both types of limit check. If one or both of the limit checks in each channel has passed, the overall limit check for that channel also passes. If both limit checks fail, the overall limit check for that channel also fails.

ACLR table

A table above the result display contains information about the measurement in numerical form:

- **Channel**
Shows the channel type (TX, Adjacent or Alternate Channel).
- **Bandwidth**
Shows the bandwidth of the channel.
- **Spacing**
Shows the channel spacing.
- **Channel Power**
Shows the absolute or relative power of the corresponding channel.
- **Δ to Limit [dB]**
Shows the minimum distance to the limit line in the corresponding channel.
- **Frequency at Δ to Limit [GHz]**
Shows the frequency of the trace point with the minimum distance to the limit line in the corresponding channel.
- **Overall Limit Check**
Shows the overall limit check results.
PASS indicates a positive result, FAIL a negative result.

Channel	Bandwidth	Spacing (Offset)	Channel Power	Δ to Limit [dB]	Frequency at Δ to Limit [GHz]	Overall Limit Check
TX	9,015 MHz		23,99 dBm			
Lower Adj	9,015 MHz	-10 MHz	-46,39 dB	-5,13	+0,994413952	PASS
Upper Adj	9,015 MHz	10 MHz	-46,72 dB	-4,53	+1,005494720	PASS
Lower Alt	9,015 MHz	-20 MHz	-66,01 dB	-37,69	+0,980143296	PASS
Upper Alt	9,015 MHz	20 MHz	-66,23 dB	-37,84	+1,022283776	PASS

Remote command:

Selecting the result display:

`CALCulate<n>:FEED 'SPEC:ACP'`

Querying results:

`CALCulate<n>:MARKer<m>:FUNCTION:POWER:RESult[:CURRENT]?`

`TRACe:DATA?`

Querying limit check results:

`CALCulate<n>:LIMit<k>:ACPpower:ACHannel:RESult?` on page 173

`CALCulate<n>:LIMit<k>:ACPpower:ALternate:RESult?` on page 174

3.4.2 I/Q Measurements

Power Spectrum.....	49
Power vs Resource Block PDSCH.....	49
Power vs Resource Block RS.....	50
Channel Flatness.....	50
Channel Flatness Difference.....	51
Channel Group Delay.....	51

Power Spectrum

Starts the Power Spectrum result display.

This result display shows the power density of the complete capture buffer in dBm/Hz. The displayed bandwidth depends on bandwidth or number of resource blocks you have set.

For more information see "[Channel Bandwidth / Number of Resource Blocks](#)" on page 95.

The x-axis represents the frequency. On the y-axis the power level is plotted.

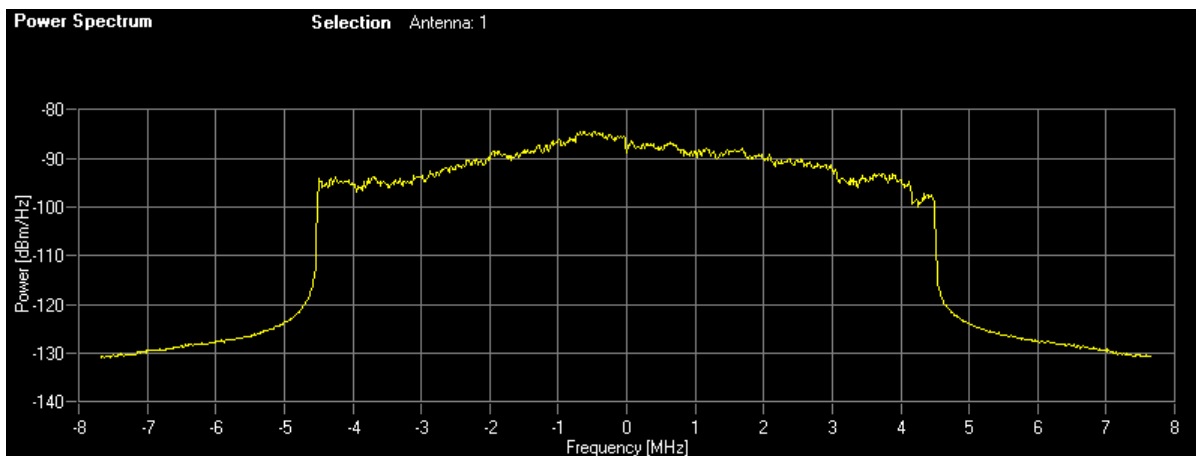

Remote command:

Selecting the result display: `CALCulate<screenid>:FEED 'SPEC:PSPE'`

Querying results: `TRACe:DATA?`

Power vs Resource Block PDSCH

Starts the Power vs Resource Block PDSCH result display.

This result display shows the power of the physical downlink shared channel per resource element averaged over one resource block.

By default, three traces are shown. One trace shows the average power. The second and the third trace show the minimum and maximum powers respectively. You can select to display the power for a specific subframe in the Subframe Selection dialog box. In that case, the application shows the powers of that subframe only.

The x-axis represents the resource blocks. The displayed number of resource blocks depends on the channel bandwidth or number of resource blocks you have set. On the y-axis, the power is plotted in dBm.

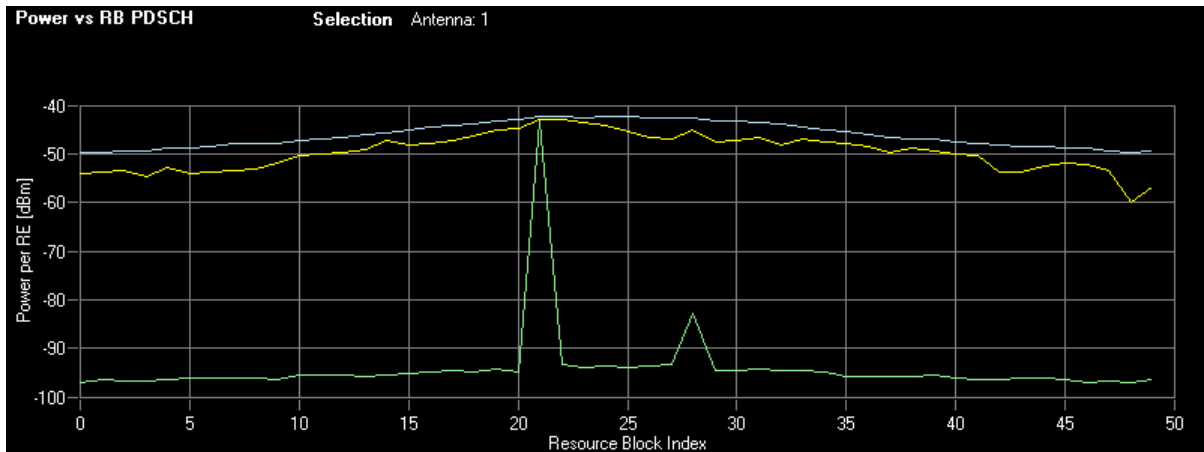

Remote command:

Selecting the result display: [CALCulate<n>:FEED 'SPEC:PVRP'](#)

Querying results: [TRACe:DATA?](#)

Power vs Resource Block RS

Starts the Power vs Resource Block RS result display.

This result display shows the power of the reference signal per resource element averaged over one resource block.

By default, three traces are shown. One trace shows the average power. The second and the third trace show the minimum and maximum powers respectively. You can select to display the power for a specific subframe in the Subframe Selection dialog box. In that case, the application shows the power of that subframe only.

The x-axis represents the resource blocks. The displayed number of resource blocks depends on the channel bandwidth or number of resource blocks you have set. On the y-axis, the power is plotted in dBm.

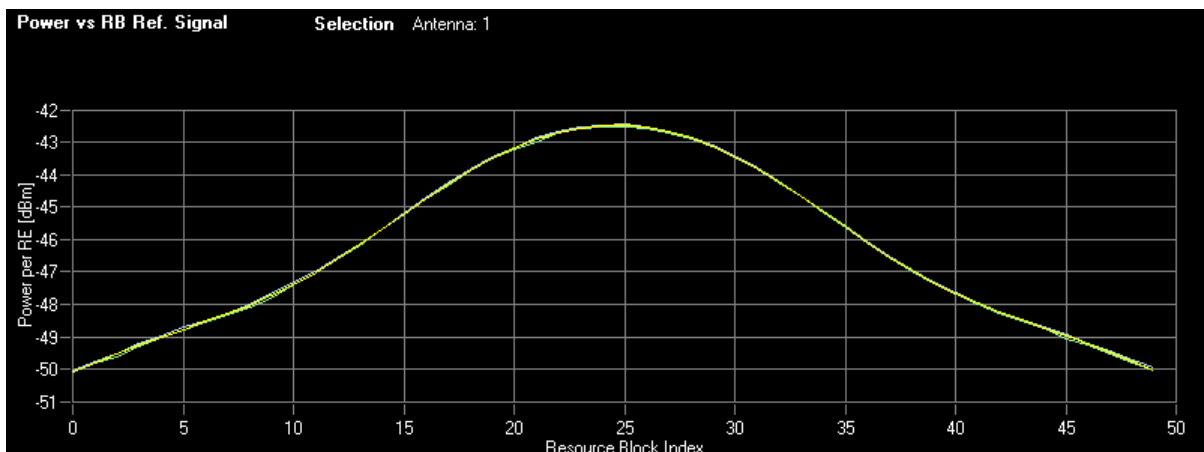

Remote command:

Selecting the result display: [CALCulate<n>:FEED 'SPEC:PVRR'](#)

Querying results: [TRACe:DATA?](#)

Channel Flatness

Starts the Channel Flatness result display.

This result display shows the relative power offset caused by the transmit channel.

The currently selected subframe depends on your [selection](#).

The x-axis represents the frequency. On the y-axis, the channel flatness is plotted in dB.

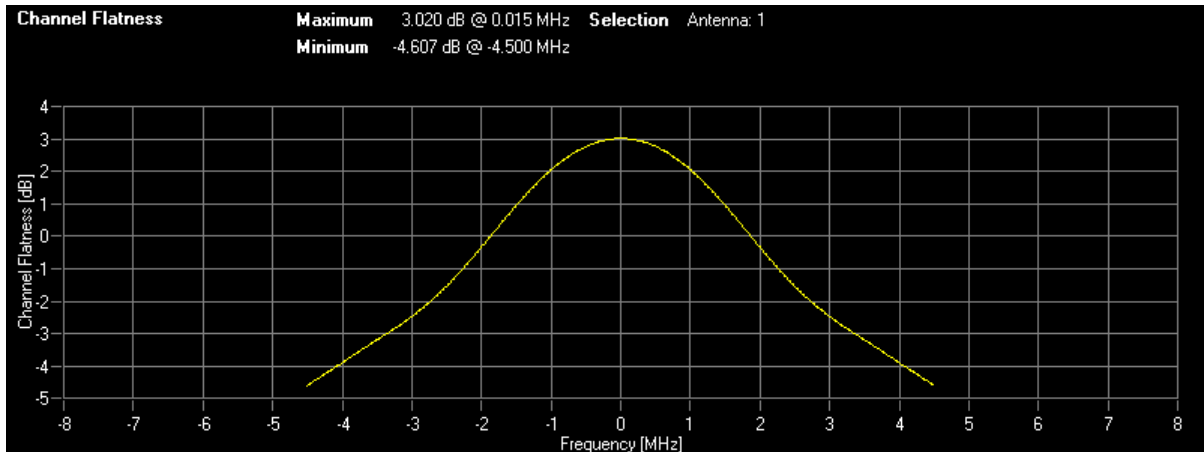

Remote command:

Selecting the result display: `CALCulate<n>:FEED 'SPEC:FLAT'`

Querying results: `TRACe:DATA?`

Channel Flatness Difference

Starts the Channel Flatness Difference result display.

This result display shows the level difference in the spectrum flatness result between two adjacent physical subcarriers.

The currently selected subframe depends on your [selection](#).

The x-axis represents the frequency. On the y-axis, the power is plotted in dB.

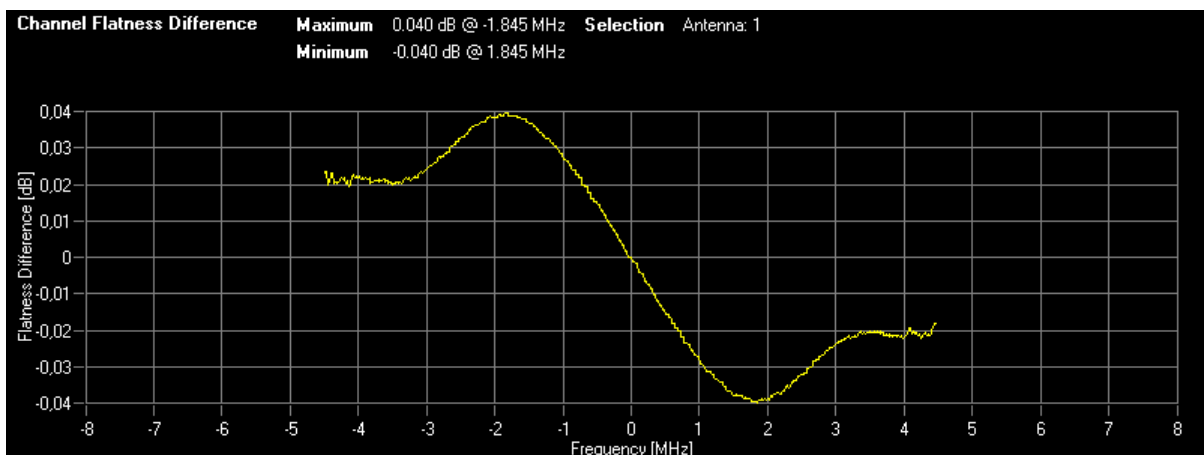

Remote command:

Selecting the result display: `CALCulate<n>:FEED 'SPEC:FDIF'`

Querying results: `TRACe:DATA?`

Channel Group Delay

Starts the Channel Group Delay result display.

This result display shows the group delay of each subcarrier.

The currently selected subframe depends on your [selection](#).

The x-axis represents the frequency. On the y-axis, the group delay is plotted in ns.

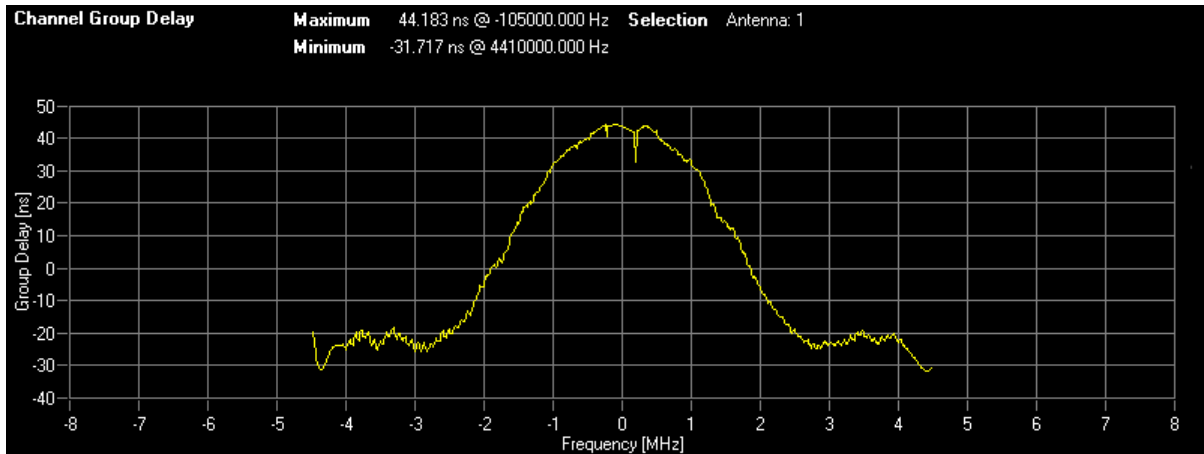

Remote command:

Selecting the result display: [CALCulate<n>:FEED 'SPEC:GDEL'](#)

Querying results: [TRACe:DATA?](#)

3.5 Measuring the Symbol Constellation

This chapter contains information on all measurements that show the constellation of a signal.

Constellation Diagram	52
Evaluation Range for the Constellation Diagram	53

Constellation Diagram

Starts the Constellation Diagram result display.

This result display shows the inphase and quadrature phase results and is an indicator of the quality of the modulation of the signal.

In the default state, the result display evaluates the full range of the measured input data. You can filter the results in the [Constellation Selection](#) dialog box.

The ideal points for the selected modulation scheme are displayed for reference purposes.

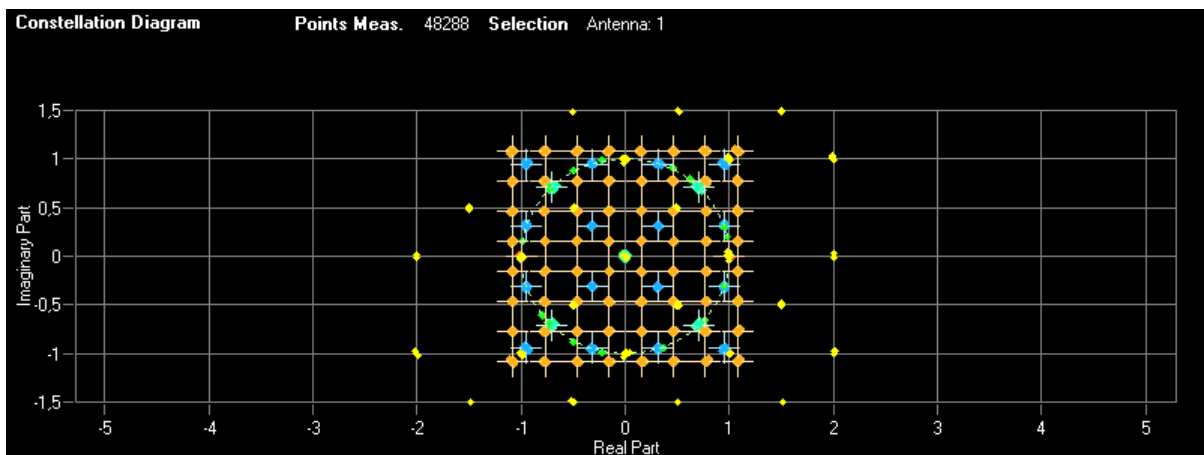

The constellation diagram also contains information about the current [evaluation range](#). In addition, it shows the number of points that are displayed in the diagram.

Remote command:

Selecting the result display: `CALCulate<n>:FEED 'CONS:CONS'`

Querying results: `TRACe:DATA?`

Evaluation Range for the Constellation Diagram

The "Evaluation Range" dialog box defines the type of constellation points that are displayed in the Constellation Diagram.

By default the software displays all constellation points of the data that have been evaluated. However, you can filter the results by several aspects.

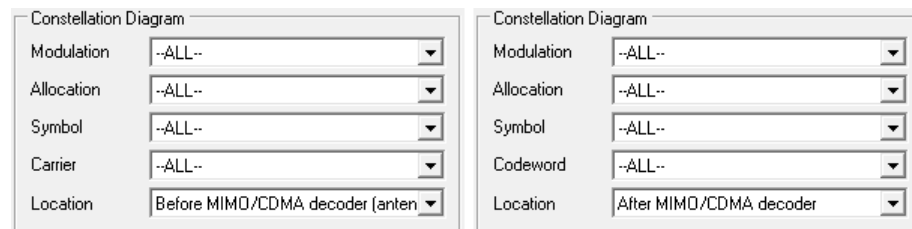

Fig. 3-4: Evaluation range for constellations before and after MIMO decoding

- Modulation
Filters the results to include only the selected type of modulation.
- Allocation
Filters the results to include only a particular type of allocation.
- Symbol
Filters the results to include only a particular OFDM symbol.
Filtering by OFDM symbols is available for constellations created before MIMO decoding.
- Carrier
Filters the results to include only a particular subcarrier.
Filtering by carrier is available for constellations created before MIMO decoding.
- Symbol
Filters the results to include only a particular codeword symbol.

Filtering by codeword symbols is available for constellations created after MIMO decoding.

- Codeword
Filters the results to include only a particular codeword.
Filtering by codeword is available for constellations created after MIMO decoding.
- Location
Selects the point in the signal processing at which the constellation diagram is created, before or after the MIMO encoding.
In case of spatial multiplexing, symbols of different encoding schemes are merged in the MIMO encoder. Thus you get a mix of different modulation alphabets. When you filter these symbols to show a modulation "MIXTURE", you get the mixed symbols only if you have selected the "Before MIMO/CDMA Decoder" option.
Note that the PHICH is CDMA encoded. Thus, the constellation points for the PHICH are either created before or after CDMA encoding.
If you have selected "After MIMO/CDMA Decoder", filtering by "Symbol" and "Carrier" is not available. Instead, you can filter by "Symbol" and "Codeword".

The result display is updated as soon as you make the changes.

Note that the constellation selection is applied to all windows in split screen mode if the windows contain constellation diagrams.

Remote command:

Location: [CONFigure\[:LTE\]:DL:CONS:LOCation](#) on page 150

3.6 Measuring Statistics

This chapter contains information on all measurements that show the statistics of a signal.

CCDF	54
Signal Flow	55
Allocation Summary	55
Bit Stream	56
Allocation ID vs Symbol x Carrier	57
Channel Decoder Results	58

CCDF

Starts the Complementary Cumulative Distribution Function (CCDF) result display.

This result display shows the probability of an amplitude exceeding the mean power. For the measurement, the complete capture buffer is used.

The x-axis represents the power relative to the measured mean power. On the y-axis, the probability is plotted in %.

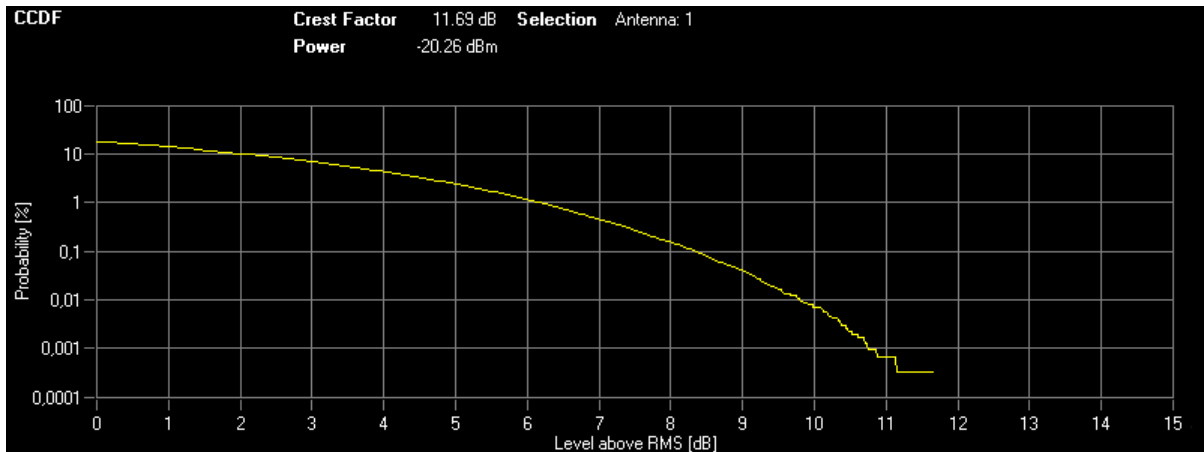

Remote command:

Selecting the result display: `CALCulate<n>:FEED 'STAT:CCDF'`

Querying results: `TRACe:DATA?`

Signal Flow

Starts the Signal Flow result display.

This result display shows the synchronization status of the current measurement. It also shows the location of the synchronization error in the signal processing.

For each synchronization block, a bar is shown giving information about the reliability of the synchronization result. If the level in the bar falls below the threshold indicated by the horizontal line, the synchronization is marked as failed and the color of the bar changes from green to red. When the synchronization of the block fails, the complete block changes its color to red and all succeeding arrows change their color to red, too.

For more information see [chapter 8, "Measurement Basics"](#), on page 126.

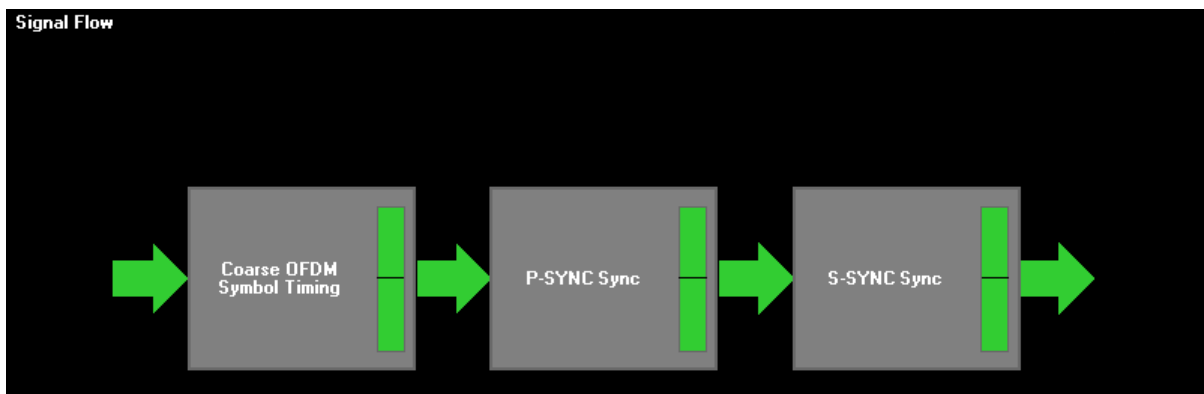

Remote command:

`CALCulate<n>:FEED 'STAT:SFLO'`

Allocation Summary

Starts the Allocation Summary result display.

This result display shows the results of the measured allocations in tabular form.

Sub-frame	Alloc. ID	Number of RB	Rel. Power/dB	Modulation	Power per RE/dBm	EVM/%
0	RS Ant1		0,000	QPSK	-45,546	1,733
	P-SYNC		-0,007	CAZAC	-42,558	1,254
	S-SYNC		0,005	RBPSK	-42,546	1,251
	PBCH		-0,003	QPSK	-42,579	1,185
	PCFICH		0,000	QPSK	-45,619	2,079
	PHICH		0,000	MIXTURE	-43,984	2,877
	PDCCH		0,001	QPSK	-47,750	1,784
	PDSCH 0	23	-0,001	64QAM	-45,321	1,092
	PDSCH 1	12	0,003	QPSK	-47,871	1,280
	ALL	35				1,333

The rows in the table represent the allocations, with allocation ALL being a special allocation that summarizes all allocations that are part of the subframe. A set of allocations form a subframe. The subframes are separated by a dashed line. The columns of the table contain the following information:

- **Subframe**
Shows the subframe number.
- **Allocation ID**
Shows the type / ID of the allocation.
- **Number of RB**
Shows the number of resource blocks assigned to the current PDSCH allocation.
- **Rel. Power/dB**
Shows the relative power of the allocation.
Note that no power is calculated for the PHICH if [Boosting Estimation](#) has been turned on. For more information see [PHICH Rel Power](#).
- **Modulation**
Shows the modulation type.
- **Power per RE [dBm]**
Shows the power of each resource element in dBm.
- **EVM**
Shows the EVM of the allocation. The unit depends on your [selection](#).

Note: PDSCH allocation with beamforming

The allocation summary shows two entries for a PDSCH allocation that uses "Beamforming (UE spec. RS)" as the precoding method.

The second entry shows the measurement results of the UE specific reference signal.

Remote command:

Selecting the result display: [CALCulate<n>:FEED 'STAT:ASUM'](#)

Querying results: [TRACe:DATA?](#)

Bit Stream

Starts the Bit Stream result display.

This result display shows the demodulated data stream for each data allocation. Depending on the [Bit Stream Format](#), the numbers represent either bits (bit order) or symbols (symbol order).

Selecting symbol format shows the bit stream as symbols. In that case the bits belonging to one symbol are shown as hexadecimal numbers with two digits. In the case of bit format, each number represents one raw bit.

Symbols or bits that are not transmitted are represented by a "-".

If a symbol could not be decoded because the number of layers exceeds the number of receive antennas, the application shows a "#" sign.

This is also the case, if PDSCH resource elements are overwritten for any reason. For more information see [Overwrite PDSCH](#) and [Enhanced Settings](#).

Sub-frame	Allocation ID	Code-word	Modulation	Symbol Index	Bit Stream
0	PBCH	1/1	QPSK	0	01 01 00 02 03 00 01 02 01 02 01 00 03 00 02 02
0	PBCH	1/1	QPSK	16	02 03 02 03 03 03 00 02 00 03 00 02 02 03 01 01
0	PBCH	1/1	QPSK	32	03 02 03 03 03 03 01 03 00 03 00 03 03 00 03 02
0	PBCH	1/1	QPSK	48	00 01 00 01 01 03 01 01 02 03 01 03 01 00 00 03
0	PBCH	1/1	QPSK	64	02 03 02 02 02 00 01 00 02 03 01 03 01 01 02 00
0	PBCH	1/1	QPSK	80	00 01 01 00 02 02 02 01 00 02 03 01 01 01 03 02
0	PBCH	1/1	QPSK	96	02 02 00 02 03 00 03 00 01 03 02 00 03 00 02 03
0	PBCH	1/1	QPSK	112	03 01 01 03 01 01 02 00 03 01 01 01 03 01 03 03
0	PBCH	1/1	QPSK	128	01 03 00 03 02 01 02 03 02 02 02 02 01 02 03 02
0	PBCH	1/1	QPSK	144	03 03 02 02 03 01 02 03 02 02 00 01 02 01 03 00

The table contains the following information:

- **Subframe**
Number of the subframe the bits belong to.
- **Allocation ID**
Channel the bits belong to.
- **Codeword**
Code word of the allocation.
- **Modulation**
Modulation type of the channels.
- **Symbol Index** or **Bit Index**
Shows the position of the table row's first bit or symbol within the complete stream.
- **Bit Stream**
The actual bit stream.

Remote command:

Selecting the result display: `CALCulate<n>:FEED 'STAT:BSTR'`

Querying results: `TRACe:DATA?`

Allocation ID vs Symbol x Carrier

The Allocation ID vs. Symbol X Carrier display shows the allocation ID of each carrier in each symbol of the received signal.

Each type of allocation is represented by a different color. Use a marker to get more information about the type of allocation.

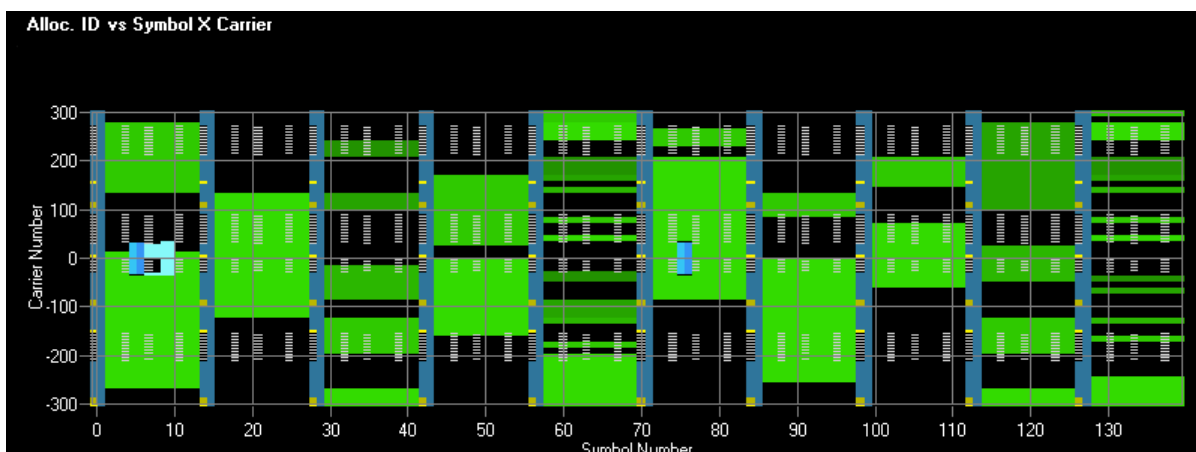

Remote command:
 Selecting the result display: `CALCulate<n>:FEED 'STAT:AISC'`
 Querying results: `TRACe:DATA?`

Channel Decoder Results

The Channel Decoder result display is a numerical result display that shows the characteristics of various channels for a particular subframe.

- Protocol information of the PBCH, PCFICH and PHICH.
- Information about the DCIs in the PDCCH.
- Decoded bitstream for each PDCCH.
- Decoded bitstream for each PDSCH.

The size of the table thus depends on the number of subframes in the signal.

Note that a complete set of results for the control channels is available only under certain circumstances.

- The corresponding control channel has to be present and enabled (see [chapter 5.3.6, "Configuring the Control Channels"](#), on page 110).
- Each channel must have a certain configuration (see list below).

Channel Decoder Results

Sub-frame	Allocation ID	Data	
0	PBCH	1 Tx Ant., Bandwidth 10 MHz PHICH normal duration, PHICH resource 1/6	
	PCFICH	2 symbols for PDCCH	
	PHICH	ACK(1) / NACK(0)	Rel. Power/dB
			0--- 00-- -3,01 - - - -3,01 -24,01 - -
			00-0 0-0- -3,01 -22,01 - -28,01 -3,01 - -21,01 -
0--0 0--- -3,01 - - -25,01 -3,01 - - -			
0--- 01-- -3,01 - - - -3,01 -23,01 - -			
1	PCFICH	2 symbols for PDCCH	

For each channel, the table shows a different set of values.

- PBCH
 For the PBCH, the Channel Decoder provides the following results.

- the MIMO configuration of the DUT (1, 2 or 4 TX antennas)
- the Transmission bandwidth
- the Duration of the PHICH (normal or extended)
- the PHICH resource which is the same as PHICH N_g (1/6, 1/2, 1 or 2)
- System frame number

If the CRC is not valid, a corresponding message is shown instead of the results. Results for the PBCH can only be determined if the [PHICH Duration](#) or the [PHICH \$N_g\$](#) are automatically determined ("Auto") or if [automatic decoding of all control channels](#) is turned on.

- PCFICH
For the PCFICH, the Channel Decoder provides the number of OFDM symbols that are used for PDCCH at the beginning of a subframe.
- PHICH
The PHICH carries the hybrid-ARQ ACK/NACK. Multiple PHICHs mapped to the same set of resource elements are a PHICH group. The PHICHs within one group are separated by different orthogonal sequences.
For the PHICH, the Channel Decoder provides the ACK/NACK pattern for the PHICH group and the relative power for each PHICH in the PHICH group. Each line in the result table represents one PHICH group. The columns on the left show the ACK/NACK pattern of the PHICH group. The columns on the right show the relative powers for each PHICH.
If a PHICH is not transmitted, the table contains a "-" sign. Otherwise, the ACK/NACK pattern is either a "1" (acknowledgement) or a "0" (not acknowledged). The relative power is a numeric value in dB.
- PDCCH
For each PDCCH that has been detected, the Channel Decoder shows several results. Each line in the table represents one PDCCH.
 - RNTI
 - DCI Format
Shows the Downlink Control Information (DCI) format. The DCI contains information about the resource assignment for the UEs.
The following DCI formats are supported: 0, 1, 1A, 1B, 1C, 2, 2A, 2C, 2D, 3, 3A.
The DCI format is determined by the length of the DCI. Because they have the same length, the Channel Decoder is not able to distinguish formats 0, 3 and 3A. Note that a DCI that consist of only zero bits cannot be decoded.
 - PDCCH format used to transmit the DCI
 - CCE Offset
The CCE Offset represents the position of the current DCI in the PDCCH bit stream.
 - Rel. Power
Relative power of the corresponding PDCCH.

Results for the PDCCH can only be determined if the [PDSCH subframe configuration](#) is detected by the "PDCCH Protocol" or if [automatic decoding of all control channels](#) is turned on.
- PDSCH
For each decoded PDSCH allocation there is a PDCCH DCI. The DCI contains parameters that are required for the decoding process. If the channel could be decoded successfully, the result display shows the bit stream for each codeword.

If the Cyclic Redundancy Check (CRC) fails, the result display shows an error message instead.

Results for the PDSCH can only be determined if the [PDSCH subframe configuration](#) is detected by the "PDCCH Protocol" or if [automatic decoding of all control channels](#) is turned on.

Remote command:

Selecting the result display: [CALCulate<screenid>:FEED 'STAT:CDR'](#)

Querying results: [TRACe:DATA?](#)

3.7 Measuring Beamforming

This chapter contains information on all measurements that show the quality of the beamforming.

For more information on beamforming phase measurements see [chapter 8.5, "Calibrating Beamforming Measurements"](#), on page 136.

UE RS Weights (Magnitude)	60
UE RS Weights (Phase)	61
UE RS Weights Difference (Phase)	62
UE RS Weights Difference (Magnitude)	62
Beamform Allocation Summary	63
Cell RS Weights (Phase)	64
Cell RS Weights Difference (Phase)	64
CSI RS Weights (Magnitude)	65
CSI RS Weights (Phase)	66
Beamforming Selection	66

UE RS Weights (Magnitude)

Starts the UE RS Weights Magnitude result display.

This result display shows the magnitude of the measured weights of the UE specific reference signal carriers. You can use it to calculate the magnitude difference between different antenna ports.

The x-axis represents the frequency, with the unit depending on your [selection](#). The y-axis shows the amplitude of each reference signal in dB.

The results correspond to the data of one subframe. Thus, the result display shows results if you have selected a particular subframe (→ [Subframe Selection](#)).

You can select the antenna port to be measured via the [Beamforming Selection](#) soft-key. Note that you can select the antenna port only if the UE RS weights phase measurement is selected.

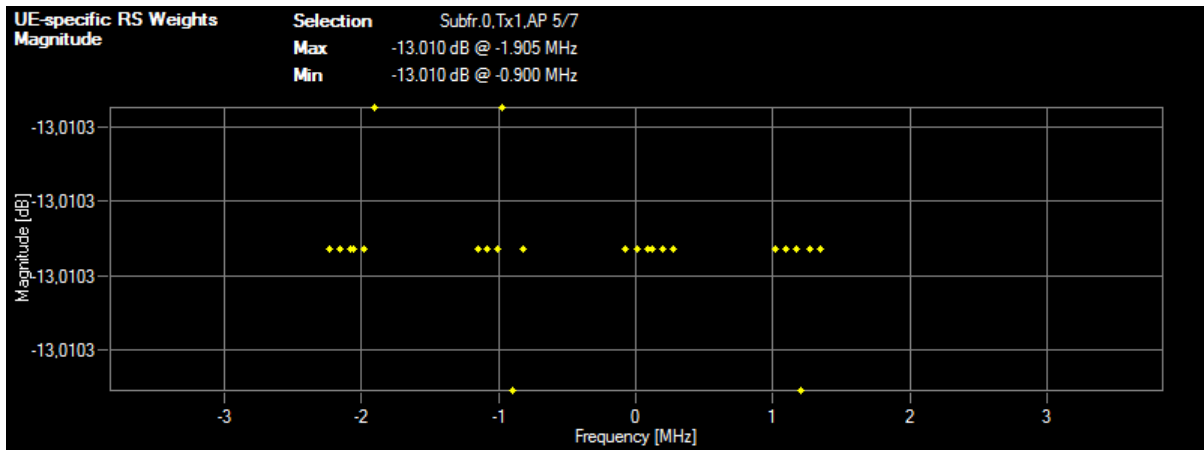

Remote command:

Selecting the result display: `CALCulate<screenid>:FEED 'BEAM:URWM'`

Querying results: `TRACe:DATA?`

UE RS Weights (Phase)

Starts the UE RS Weights Phase result display.

This result display shows the phase of the measured weights of the UE specific reference signal carriers. You can use it to calculate the phase difference between different antenna ports.

The x-axis represents the frequency, with the unit depending on your [selection](#). The y-axis shows the phase of each reference signal in degree.

The results correspond to the data of one subframe. Thus, the result display shows results if you have selected a particular subframe (→ [Subframe Selection](#)).

You can select the antenna port to be measured via the [Beamforming Selection](#) soft-key. Note that you can select the antenna port only if the UE RS weights phase measurement is selected.

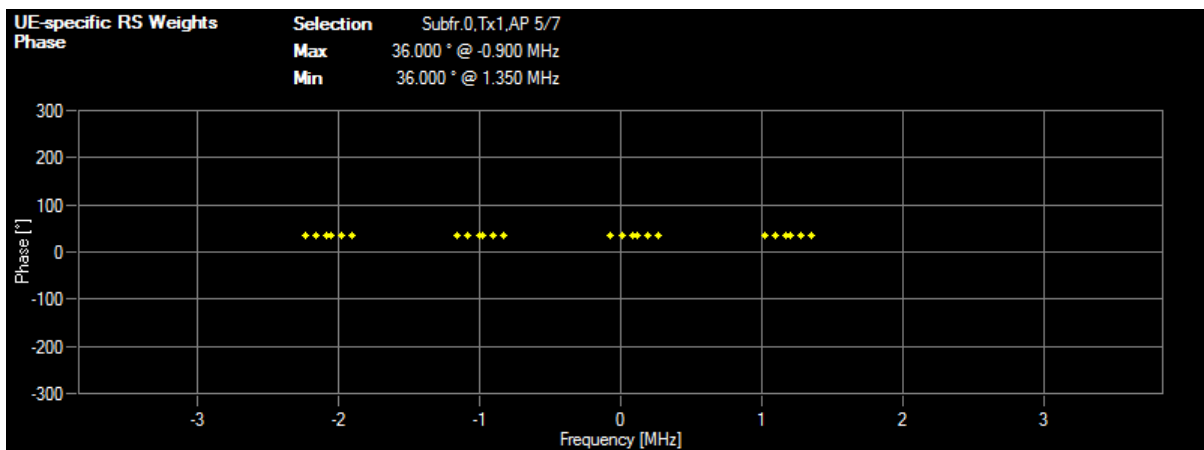

Remote command:

Selecting the result display: `CALCulate<screenid>:FEED 'BEAM:URWP'`

Querying results: `TRACe:DATA?`

UE RS Weights Difference (Phase)

Starts the UE RS Weights Difference Phase result display.

This result display shows the phase difference of the measured weights of the UE specific reference signals between multiple antenna ports. The reference antenna for this measurement is always antenna one.

The x-axis represents the frequency, with the unit depending on your [selection](#). The y-axis shows the phase difference of each reference signal in degree.

The results correspond to the data of one subframe. Thus, the result display shows results if you have selected a particular subframe (→ [Subframe Selection](#)).

You can select the antenna port to be measured via the [Beamforming Selection](#) soft-key. Note that you can select the antenna port only if the UE RS weights phase measurement is selected.

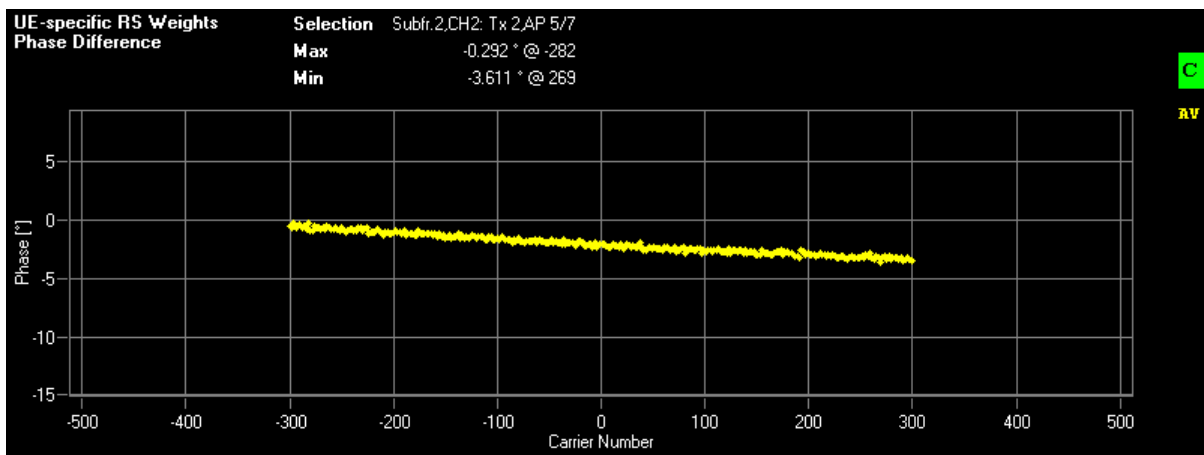

Remote command:

Selecting the result display: `CALCulate<screenid>:FEED 'BEAM:URPD'`

Querying results: `TRACe:DATA?`

UE RS Weights Difference (Magnitude)

Starts the UE RS Weights Difference Magnitude result display.

This result display shows the amplitude difference of the measured weights of the UE specific reference signals between multiple antenna ports. The reference antenna for this measurement is always antenna one.

The x-axis represents the frequency, with the unit depending on your [selection](#). The y-axis shows the amplitude of each reference signal in dB.

The results correspond to the data of one subframe. Thus, the result display shows results if you have selected a particular subframe (→ [Subframe Selection](#)).

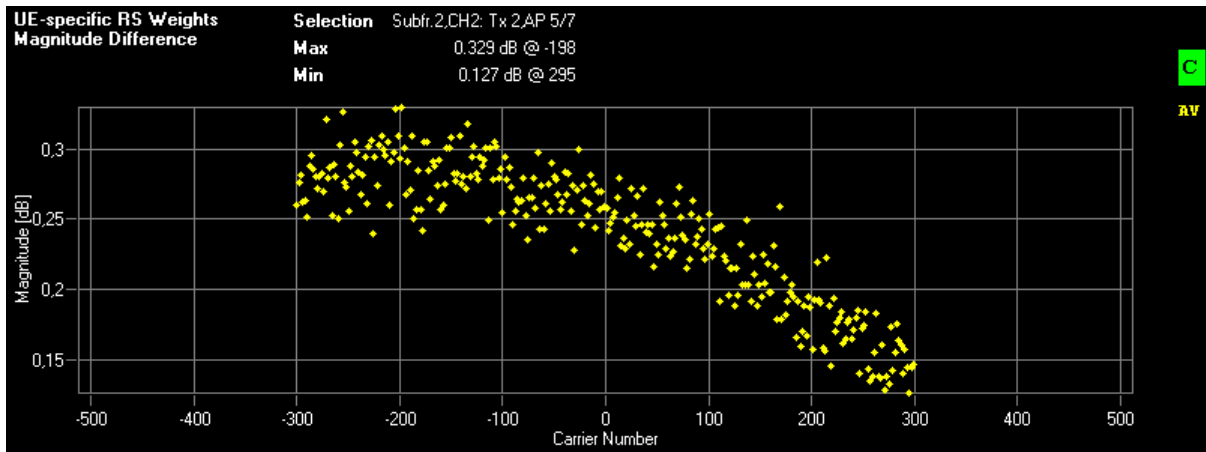

Remote command:
 Selecting the result display: [CALCulate<screenid>:FEED 'BEAM:URMD'](#)
 Querying results: [TRACe:DATA?](#)

Beamform Allocation Summary

Starts the Beamform Allocation Summary result display.

The result display shows the phase characteristics for each PDSCH and (if available) EPDCCH allocation used by the UE specific reference signals in numerical form.

UE-specific RS Weights vs Allocation

Selection Subfr.0,AP 5/7

CH1: Tx 1				CH2: Tx 2			
Sub-frame	Allocation ID	Phase/°	Phase Diff/°	Sub-frame	Allocation ID	Phase/°	Phase Diff/°
0	PDSCH 0	-121,928		0	PDSCH 0	-124,007	-2,079

The rows in the table represent the allocations. A set of allocations form a subframe. The subframes are separated by a dashed line. The columns of the table contain the following information:

- **Subframe**
Shows the subframe number.
- **Allocation ID**
Shows the type / ID of the allocation.
- **Phase**
Shows the phase of the allocation.
- **Phase Diff(ERENCE)**

Shows the phase difference of the allocation relative to the first antenna.

Remote command:

Selecting the result display: `CALCulate<screenid>:FEED 'BEAM:URWA'`

Querying results: `TRACe:DATA?`

Cell RS Weights (Phase)

Starts the Cell RS Weights Phase result display.

This result display shows the phase of the measured weights of the reference signal (RS) carriers specific to the cell. This measurement enables phase measurements on antenna port 0 using, for example, the enhanced test models like E-TM 1.1.

You can use the result display to calculate the phase difference between different antenna ports.

The x-axis represents the frequency, with the unit depending on your [selection](#). The y-axis shows the phase of each reference signal in degree.

The results correspond to the data of one subframe. Thus, the result display shows results if you have selected a particular subframe (→ [Subframe Selection](#)).

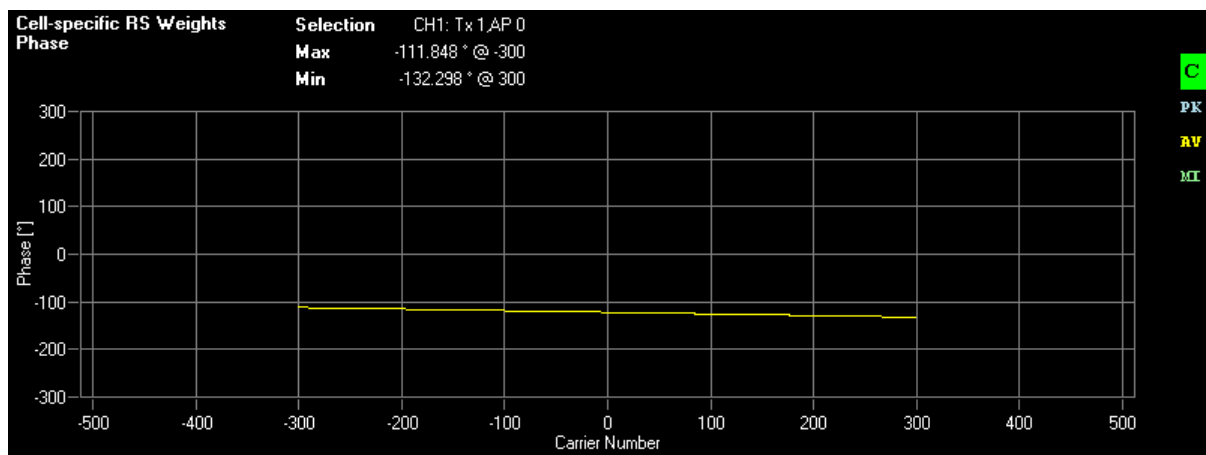

Remote command:

Selecting the result display: `CALCulate<screenid>:FEED 'BEAM:CRWP'`

Querying results: [chapter 9.6.1.8, "Cell RS Weights Phase \(Difference\)"](#), on page 162

Cell RS Weights Difference (Phase)

Starts the Cell RS Weights Phase result display.

This result display shows the phase difference of the measured weights of the reference signal (RS) carriers specific to the cell. This measurement enables phase measurements on antenna port 0 using, for example, the enhanced test models like E-TM 1.1.

The reference antenna for this measurement is always antenna one.

The x-axis represents the frequency, with the unit depending on your [selection](#). The y-axis shows the phase of each reference signal in degree.

The results correspond to the data of one subframe. Thus, the result display shows results if you have selected a particular subframe (→ [Subframe Selection](#)).

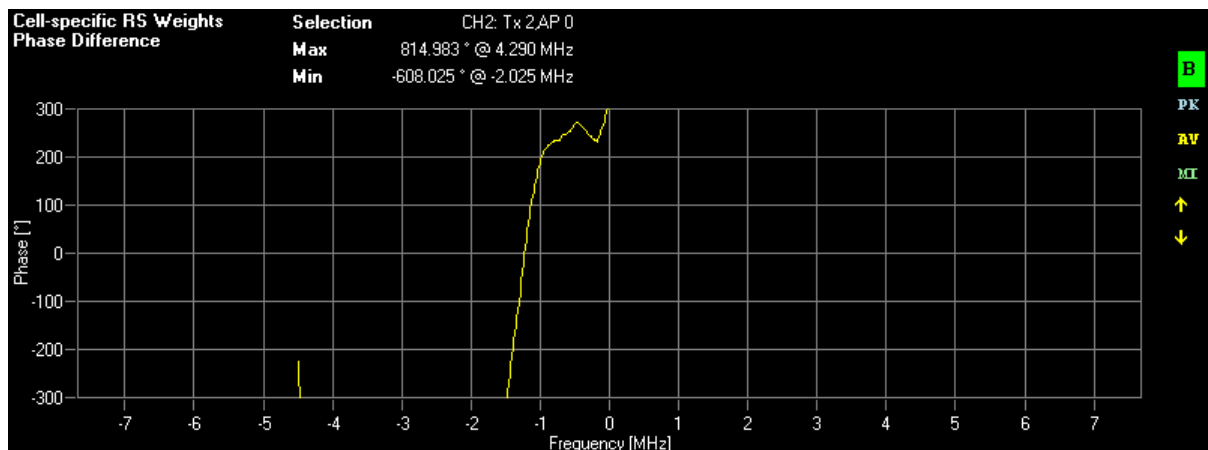

Remote command:

Selecting the result display: `CALCulate<screenid>:FEED 'BEAM:CRPD'`

Querying results: [chapter 9.6.1.8, "Cell RS Weights Phase \(Difference\)"](#), on page 162

CSI RS Weights (Magnitude)

Starts the CSI RS Weights Magnitude result display.

This result display shows the magnitude of the measured weights of the CSI specific reference signal carriers. You can use it to calculate the magnitude difference between different antenna ports.

The x-axis represents the frequency, with the unit depending on your [selection](#). The y-axis shows the amplitude of each reference signal in dB.

The results correspond to the data of one subframe. Thus, the result display shows results if you have selected a particular subframe (→ [Subframe Selection](#)).

You can select the antenna port to be measured via the [Beamforming Selection](#) soft-key. Note that you can select the antenna port only if the UE RS weights magnitude measurement is selected.

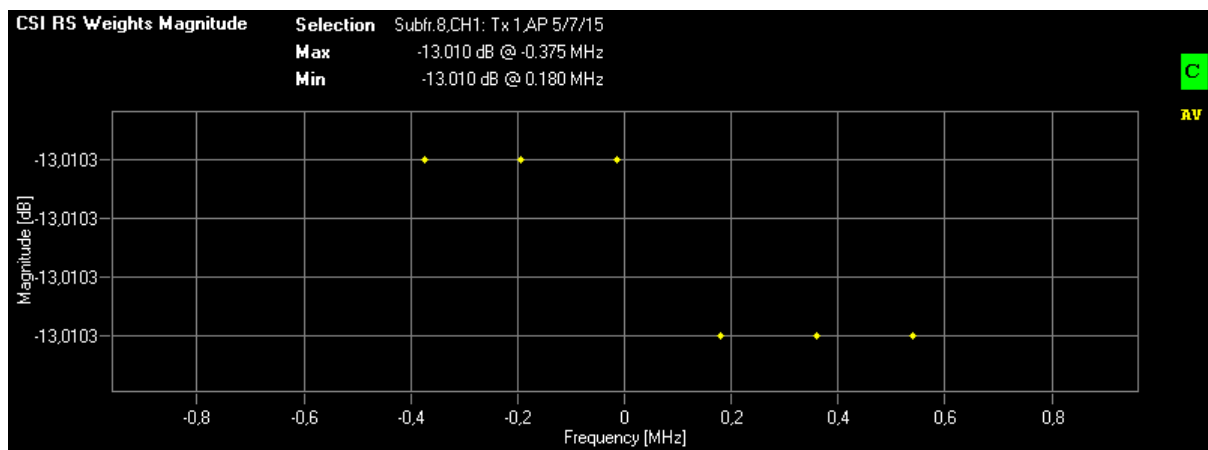

Remote command:

Selecting the result display: `CALCulate<screenid>:FEED 'BEAM:IRWM'`

Querying results: `TRACe:DATA?`

CSI RS Weights (Phase)

Starts the CSI RS Weights Phase result display.

This result display shows the phase of the measured weights of the CSI specific reference signal carriers. You can use it to calculate the phase difference between different antenna ports.

The x-axis represents the frequency, with the unit depending on your [selection](#). The y-axis shows the phase of each reference signal in degree.

The results correspond to the data of one subframe. Thus, the result display shows results if you have selected a particular subframe (→ [Subframe Selection](#)).

You can select the antenna port to be measured via the [Beamforming Selection](#) soft-key. Note that you can select the antenna port only if the CSI RS weights phase measurement is selected.

Remote command:

Selecting the result display: [CALCulate<screenid>:FEED 'BEAM:IRWP'](#)

Querying results: [TRACe:DATA?](#)

Beamforming Selection

Filters the displayed results to include only certain antenna port(s).

The availability of antenna ports depends on the number of transmission antennas and the number of beamforming layers you are testing.

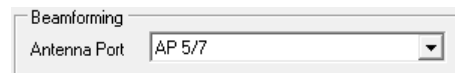

Remote command:

[CONFigure\[:LTE\]:DL:BF:AP](#) on page 150

3.8 3GPP Test Scenarios

3GPP defines several test scenarios for measuring base stations. These test scenarios are described in detail in 3GPP TS 36.141.

The following table provides an overview which measurements available in the LTE software are suited to use for the test scenarios in the 3GPP documents.

Table 3-1: Test scenarios for E-TMs as defined by 3GPP (3GPP TS 36.141)

Test Model	Test scenario	Test described in	Measurement
E-TM1.1	Base station output power	chapter 6.2	Power (→ Result Summary)
	Transmit On/Off power	chapter 6.4	On/Off Power
	DL RS power	chapter 6.5.4	RSTP (→ Result Summary)
	Time alignment	chapter 6.5.3	Time Alignment Error
	Transmitter intermodulation	chapter 6.7	ACLR
	Occupied bandwidth	chapter 6.6.1	Occupied Bandwidth ¹
	ACLR	chapter 6.6.2	ACLR

Test Model	Test scenario	Test described in	Measurement
	Operating band unwanted emissions	chapter 6.6.3	Spectrum Emission Mask
	Transmitter spurious emissions	chapter 6.6.4	Spurious Emissions ¹
E-TM1.2	ACLR	chapter 6.6.2	ACLR
	Operating band unwanted emissions	chapter 6.6.2	Spectrum Emission Mask
E-TM2	RE power control dynamic range	chapter 6.3.1	Power results
	Frequency error	chapter 6.5.1	Frequency Error (→ Result Summary)
	Total power dynamic range	chapter 6.3.2	OSTP (→ Result Summary)
	Error Vector Magnitude	chapter 6.5.2	EVM results
E-TM3.1	RE power control dynamic range	chapter 6.3.1	Power results
	Total power dynamic range	chapter 6.3.2	OSTP (→ Result Summary)
	Frequency error	chapter 6.5.1	Frequency Error (→ Result Summary)
	Error Vector Magnitude	chapter 6.5.2	EVM results
E-TM3.2	RE power control dynamic range	chapter 6.3.1	Power results
	Frequency error	chapter 6.5.1	Frequency Error (→ Result Summary)
	Error Vector Magnitude	chapter 6.5.2	EVM results
E-TM3.3	RE power control dynamic range	chapter 6.3.1	Power results
	Frequency error	chapter 6.5.1	Frequency Error (→ Result Summary)
	Error Vector Magnitude	chapter 6.5.2	EVM results

¹these measurements are available in the Spectrum application of the Rohde & Schwarz signal and spectrum analyzers (for example the R&S FSW)

4 General Settings

The following chapter contains all settings that are available in the "General Settings" dialog box.

- [Configuring the Measurement](#).....68
- [Configuring MIMO Measurement Setups](#).....78
- [Triggering Measurements](#).....81
- [Spectrum Settings](#).....82
- [Advanced Settings](#).....84

4.1 Configuring the Measurement

The general settings contain various settings that configure the general measurement setup.

You can find the signal characteristics in the "General Settings" dialog box.

- [Defining General Signal Characteristics](#).....68
- [Configuring the Input](#).....69
- [Configuring the Input Level](#).....70
- [Configuring the Data Capture](#).....72
- [Configuring Measurement Results](#).....74
- [Configuring Time Alignment Measurements](#).....76
- [Configuring Transmit On/Off Power Measurements](#).....77

4.1.1 Defining General Signal Characteristics

The general signal characteristics contain settings to describe the general physical attributes of the signal.

The signal characteristics are part of the "General Settings" tab of the "General Settings" dialog box.

Signal Characteristics	
Standard	3GPP LTE
Duplexing	TDD
Link Direction	Uplink
Frequency	1 GHz

- [Selecting the LTE Mode](#).....68
- [Defining the Signal Frequency](#).....69

Selecting the LTE Mode

The LTE mode is a combination of the "Standard" (always 3GPP LTE), the "Duplexing" mode and the "Link Direction".

The choices you have depend on the set of options you have installed.

- option FSx-K100(PC) enables testing of 3GPP LTE FDD signals on the downlink
- option FSx-K101(PC) enables testing of 3GPP LTE FDD signals on the uplink
- option FSx-K102(PC) enables testing of 3GPP LTE MIMO signals on the downlink
- option FSx-K103(PC) enables testing of 3GPP MIMO signals on the uplink
- option FSx-K104(PC) enables testing of 3GPP LTE TDD signals on the downlink
- option FSx-K105(PC) enables testing of 3GPP LTE TDD signals on the uplink

FDD and TDD are **duplexing** methods.

- FDD mode uses different frequencies for the uplink and the downlink.
- TDD mode uses the same frequency for the uplink and the downlink.

Downlink (DL) and Uplink (UL) describe the **transmission path**.

- Downlink is the transmission path from the base station to the user equipment. The physical layer mode for the downlink is always OFDMA.
- Uplink is the transmission path from the user equipment to the base station. The physical layer mode for the uplink is always SC-FDMA.

The software shows the currently selected LTE mode (including the bandwidth) in the header table.

Freq	1 GHz	CP/Cell ID	E
Mode	UL TDD, 10 MHz	Sync State	-

Remote command:

Link direction: [CONFigure\[:LTE\]:LDIREction](#) on page 182

Duplexing mode: [CONFigure\[:LTE\]:DUPLexing](#) on page 182

Defining the Signal Frequency

For measurements with an RF input source, you have to match the **center frequency** of the analyzer to the frequency of the signal.

The software shows the current center frequency in the header table.

Freq	1 GHz	CP/Cell ID	E
Mode	UL TDD, 10 MHz	Sync State	-

The available frequency range depends on the hardware configuration of the analyzer you are using.

Remote command:

Center frequency: [\[SENSe\]:FREQuency:CENTer\[:CC<cci>\]](#) on page 182

4.1.2 Configuring the Input

The input settings control the basic configuration of the input.

The input source selection is part of the "General Settings" tab of the "General Settings" dialog box.

For more information on advanced input configuration see [chapter 4.5, "Advanced Settings"](#), on page 84.

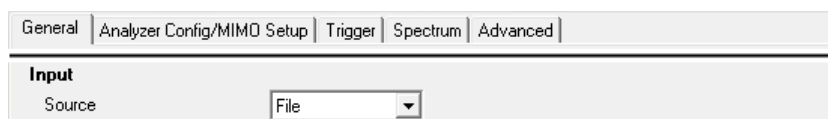

Selecting the Input Source..... 70

Selecting the Input Source

The input source selects the source of the data you'd like to analyze. You can either analyze a live signal or a signal that has been recorded previously and whose characteristics have been saved to a file.

You can select the input source from the "Source" dropdown menu.

- RF
Captures and analyzes the data from the RF input of the spectrum analyzer in use.
- Baseband (BB)
Captures and analyzes the data from the baseband input of the spectrum analyzer in use.
Note that you have to use an analyzer that supports analog baseband input if you select that input source.
- Digital I/Q
Captures and analyzes the data from the digital baseband input of the spectrum analyzer in use.
Note that you have to use an analyzer that supports digital baseband input if you select that input source.
- File
Analyzes data that has been recorded already and has been saved to a file.
If selected, the software asks you to select a file from a dialog box after you have initiated a measurement. If the file contents are not valid or the file could not be found, the software shows an error message.
A connection to an analyzer or a dongle is required to successfully load a file.
For more information see [chapter 7.1, "Importing and Exporting I/Q Data"](#), on page 122.

Remote command:

Input source selection: [SENSe:INPut](#) on page 183

Loading I/Q data from file: [MMEMory:LOAD:IQ:STATe](#) on page 227

4.1.3 Configuring the Input Level

The level settings contain settings that control the input level of any analyzer in the measurement setup.

You can control the input level for any of the input channels you are using separately from the dropdown menu next to the "Level Settings" label.

The level settings are part of the "General Settings" tab of the "General Settings" dialog box.

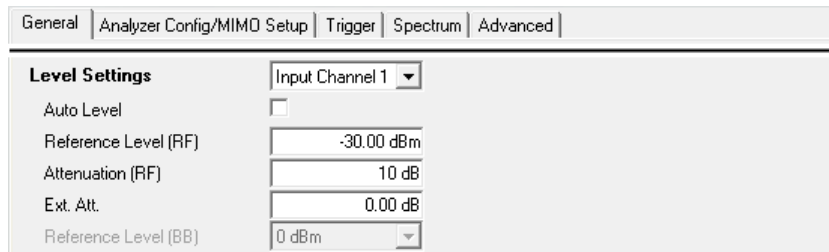

Defining a Reference Level.....71
 Attenuating the Signal.....72

Defining a Reference Level

The reference level is the power level the analyzer expects at the RF input. Keep in mind that the power level at the RF input is the peak envelope power in case of signals with a high crest factor like LTE.

To get the best dynamic range, you have to set the reference level as low as possible. At the same time, make sure that the maximum signal level does not exceed the reference level. If it does, it will overload the A/D converter, regardless of the signal power. Measurement results may deteriorate (e.g. EVM). This applies especially for measurements with more than one active channel near the one you are trying to measure (± 6 MHz).

Note that the signal level at the A/D converter may be stronger than the level the application displays, depending on the current resolution bandwidth. This is because the resolution bandwidths are implemented digitally after the A/D converter.

You can either specify the **RF Reference Level** (in dBm) or **Baseband Reference Level** (in V), depending on the [input source](#).

You can also use **automatic detection** of the reference level with the "Auto Level" function.

If active, the software measures and sets the reference level to its ideal value before each sweep. This process slightly increases the measurement time. You can define the measurement time of that measurement with the **Auto Level Track Time** (→ "Advanced" tab).

Automatic level detection also optimizes RF attenuation.

Automatic level detection is available for an RF input source.

The software shows the current reference level of the first input channel (including RF and external attenuation) in the header table.

Master Ref Level	-20.00 dBm, 15 dB (10 dB)
Capture Time/Frame	20.10 ms/-

Remote command:

Manual (RF): `CONFigure:POWer:EXPEcted:RF<instrument>` on page 184

Manual (BB): `CONFigure:POWer:EXPEcted:IQ<instrument>` on page 184

Automatic: `[SENSE]:POWer:AUTO<instrument>[:STATE]` on page 183

Auto Level Track Time: `[SENSE]:POWer:AUTO<instrument>:TIME` on page 197

Attenuating the Signal

Attenuation of the signal may become necessary if you have to reduce the power of the signal that you have applied. Power reduction is necessary, for example, to prevent an overload of the input mixer.

You can attenuate the signal at the RF input of one of the analyzers in the measurement setup (mechanical or **RF attenuation**) or attenuate the signal externally (**external attenuation**).

If you attenuate or amplify the signal either way, the software adjusts the numeric and graphical results accordingly. In case of graphical power result displays, it moves the trace(s) vertically by the specified value.

Positive values correspond to an attenuation and negative values correspond to an amplification.

The range of the RF attenuation depends on the hardware you are using in the measurement setup. For details refer to its data sheet. If the attenuation you have set is not supported by the hardware, the software corrects the attenuation and shows a corresponding message.

The software shows the RF and external attenuation level in the header table next to the reference level.

Master Ref Level	-20.00 dBm, 15 dB (10 dB)
Capture Time/Frame	20.10 ms/-

Remote command:

RF attenuation: `INPut<n>:ATTenuation<instrument>` on page 184

External attenuation: `DISPlay[:WINDow<n>]:TRACe<t>:Y[:SCALE]:RLEVEL:OFFSET` on page 185

4.1.4 Configuring the Data Capture

The data capture settings contain settings that control the amount of data and the way that the software records the LTE signal.

The data capture settings are part of the "General Settings" tab of the "General Settings" dialog box.

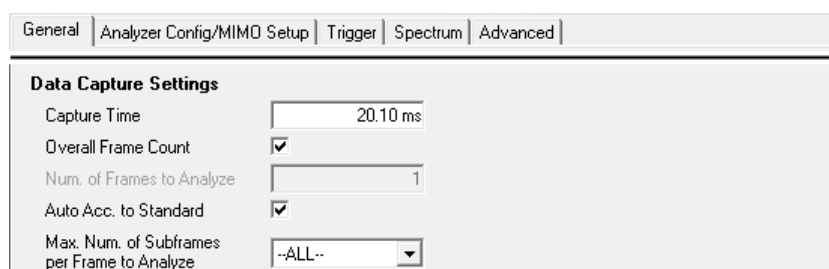

Capture Time.....	73
Overall Frame Count.....	73
Number of Frames to Analyze.....	73
Auto According to Standard.....	73
Maximum Number of Subframes per Frame to Analyze.....	74

Capture Time

Defines the capture time.

The capture time corresponds to the time of one sweep. Hence, it defines the amount of data the software captures during one sweep.

By default, the software captures 20.1 ms of data to make sure that at least one complete LTE frame is captured in one sweep.

The software shows the current capture time (including the frame number) in the header table.

Master Ref Level	-20.00 dBm, 15 dB (10 dB)
Capture Time/Frame	20.10 ms/-

Remote command:

[\[SENSe\] :SWEep:TIME](#) on page 185

Overall Frame Count

Turns the manual selection of the number of frames to capture (and analyze) on and off.

If the overall frame count is active, you can define a particular number of frames to capture and analyze. The measurement runs until all required frames have been analyzed, even if it takes more than one sweep. The results are an average of the captured frames.

If the overall frame count is inactive, the software analyzes all complete LTE frames currently in the capture buffer.

Remote command:

[\[SENSe\] \[:LTE\] :FRAMe:COUNT:STATe](#) on page 185

Number of Frames to Analyze

Sets the number of frames that you want to capture and analyze.

If the number of frames you have set last longer than a single sweep, the software continues the measurement until all frames have been captured.

The parameter is read only if

- the overall frame count is inactive,
- the data is captured [according to the standard](#).

Remote command:

[\[SENSe\] \[:LTE\] :FRAMe:COUNT](#) on page 185

Auto According to Standard

Turns automatic selection of the number of frames to capture and analyze on and off.

If active, the software evaluates the number of frames as defined for EVM tests in the LTE standard.

If inactive, you can set the number of frames you want to analyze.

This parameter is not available if the overall frame count is inactive.

Remote command:

[\[SENSe\] \[:LTE\] :FRAMe:COUNT:AUTO](#) on page 186

Maximum Number of Subframes per Frame to Analyze

Selects the maximum number of subframes that the software analyzes and therefore improves measurement speed.

Reducing the number of analyzed subframes may become necessary if you define a capture time of less than 20.1 ms. For successful synchronization, all subframes that you want to analyze must be in the capture buffer. You can make sure that this is the case by using, for example, an external frame trigger signal.

For maximum measurement speed turn off [Auto According to Standard](#) and set the [Number of Frames to Analyze](#) to 1. These settings prevent the software from capturing more than once for a single run measurement.

Remote command:

[\[SENSe\] \[:LTE\] :FRAMe:SCOunt](#) on page 186

4.1.5 Configuring Measurement Results

The measurement result settings contain settings that define certain aspects of the results that are displayed.

The result settings are part of the "General Settings" tab of the "General Settings" dialog box.

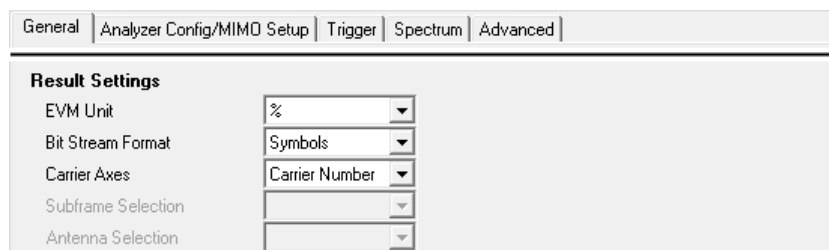

[EVM Unit](#)..... 74
[Bit Stream Format](#)..... 74
[Carrier Axes](#)..... 75
[Subframe Selection](#)..... 75
[Antenna Selection](#)..... 76

EVM Unit

Selects the unit for graphic and numerical EVM measurement results.

Possible units are dB and %.

Remote command:

[UNIT:EVM](#) on page 187

Bit Stream Format

Selects the way the bit stream is displayed.

The bit stream is either a stream of raw bits or of symbols. In case of the symbol format, the bits that belong to a symbol are shown as hexadecimal numbers with two digits.

Examples:

B Bit Stream		Subframe(s)	ALL	Bit Stream																
Sub-frame	Allocation ID	Code-word	Modulation	Symbol Index																
0	PBCH	1/1	QPSK	0	02	00	00	00	01	00	00	02	00	03	00	00	02	01	03	00
0	PBCH	1/1	QPSK	16	02	02	02	03	00	00	03	01	03	02	02	01	02	03	02	01
0	PBCH	1/1	QPSK	32	00	01	01	00	00	02	02	03	01	00	03	03	03	01	02	01
0	PBCH	1/1	QPSK	48	00	02	01	01	02	03	03	03	00	02	01	02	02	02	01	02

Fig. 4-1: Bit stream display in downlink application if the bit stream format is set to "symbols"

B Bit Stream		Subframe(s)	ALL	Bit Stream						
Sub-frame	Allocation ID	Code-word	Modulation	Bit Index						
0	PBCH	1/1	QPSK	0	10000000001000010000110000100111001010101100001101					
0	PBCH	1/1	QPSK	48	111010011011100100010100001010110100111111011001					
0	PBCH	1/1	QPSK	96	001001011011111100100110101001100110000000110001					
0	PBCH	1/1	QPSK	144	100101000110100101111111010001011000111010110010					

Fig. 4-2: Bit stream display in downlink application if the bit stream format is set to "bits"

Remote command:

UNIT:BSTR on page 187

Carrier Axes

Selects the scale of the x-axis for result displays that show results of OFDM subcarriers.

- X-axis shows the frequency of the subcarrier

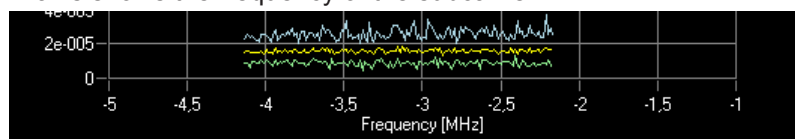

- X-axis shows the number of the subcarrier

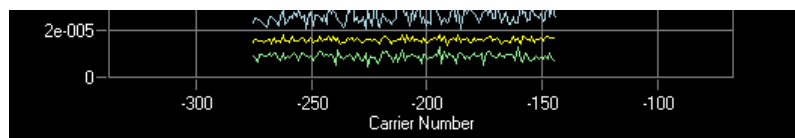

Remote command:

UNIT:CAXes on page 187

Subframe Selection

Selects a particular subframe whose results the software displays.

You can select a particular subframe for the following measurements.

Result Summary, EVM vs. Carrier, EVM vs. Symbol, EVM vs. Symbol x Carrier, Channel Flatness, Channel Group Delay, Channel Flatness Difference, Power vs Symbol x Carrier, Constellation Diagram, Allocation Summary, Bit Stream and Time Alignment. If ---All--- is selected, either the results from all subframes are displayed at once or a statistic is calculated over all analyzed subframes.

Selecting "All" either displays the results over all subframes or calculates a statistic over all subframes that have been analyzed.

Example: Subframe selection

If you select all subframes ("All"), the software shows three traces. One trace shows the subframe with the minimum level characteristics, the second trace shows the subframe with the maximum level characteristics and the third subframe shows the averaged level characteristics of all subframes.



- PK: peak value
- AV: average value
- MI: minimum value

If you select a specific subframe, the software shows one trace. This trace contains the results for that subframe only.



Remote command:

[SENSe] [:LTE]:SUBFrame:SElect on page 188

Antenna Selection

Selects the antenna you want to display the results for.

For more information see "MIMO Configuration" on page 79.

Remote command:

[SENSe] [:LTE]:ANTenna:SElect on page 187

[SENSe] [:LTE]:SOURce:SElect on page 188

4.1.6 Configuring Time Alignment Measurements

The Time Alignment measurement settings contain settings that define certain aspects of this measurement.

The Time Alignment measurement settings are part of the "General Settings" tab of the "General Settings" dialog box.

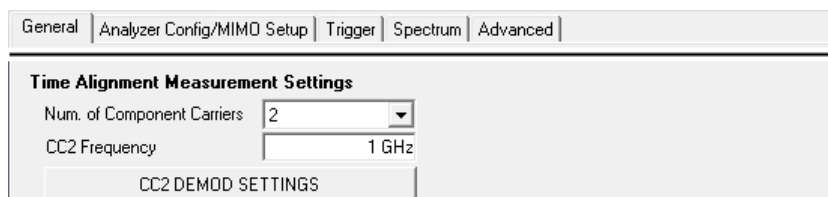

[Carrier Aggregation](#).....77

Carrier Aggregation

The software supports Time Alignment Error measurements with carrier aggregation. Select the number of carriers from the **"Number of Component Carriers"** dropdown menu.

If you select more than one carrier, define the frequency of the other carrier in the **"CC2 Frequency"** field.

The **"CC2 Demod Settings"** button opens a dialog box to configure the signal characteristics of the second carrier. This dialog contains a selection of the demodulation settings.

For more information see [chapter 5, "Demod Settings"](#), on page 89.

Note that the software shows measurement results for the second component carrier even if only one antenna of the second component carrier is attached (i.e. no combiner is used).

Remote command:

[CONFigure:NOCC](#) on page 189

[\[SENSe\]:FREQuency:CENTer\[:CC<cci>\]](#) on page 182

CC2 Demod settings: see [chapter 9.8, "Remote Command to Configure the Demodulation"](#), on page 199

4.1.7 Configuring Transmit On/Off Power Measurements

The On/Off Power measurement settings contain settings that define certain aspects of those measurements.

The On/Off Power measurement settings are part of the "General Settings" tab of the "General Settings" dialog box.

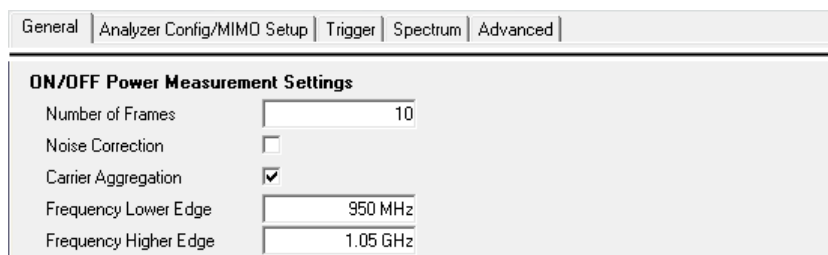

[Number of Frames](#)..... 77

[Noise Correction](#)..... 78

[Carrier Aggregation](#)..... 78

Number of Frames

Defines the number of frames that are averaged to calculate a reliable power trace for On/Off Power measurements.

Remote command:

[CONFigure\[:LTE\]:OOPower:NFRames](#) on page 190

Noise Correction

Turns noise correction for On/Off Power measurements on and off.

Remote command:

[SENSe] [:LTE] :OOPower:NCORrection on page 190

Carrier Aggregation

The software supports Transmit On/Off Power measurements with carrier aggregation.

To turn on measurements on more than one carrier, check the "Carrier Aggregation" parameter. If on, the "Frequency Lower Edge" and "Frequency Higher Edge" field become available.

When defining the lower and higher frequency, make sure to that the values are valid.

- The center frequency of the master component carrier (→ [Defining the Signal Frequency](#)) has to be within the bandwidth defined by the lower and higher edge frequencies.
- The bandwidth defined by the lower and higher edge frequencies must not be too large.

If one of these conditions is not met, the fields turn red or the software shows an error message.

Remote command:

[SENSe] [:LTE] :OOPower:CAGGregation on page 189

[SENSe] [:LTE] :OOPower:FREQuency:LOWer on page 190

[SENSe] [:LTE] :OOPower:FREQuency:HIGHer on page 189

4.2 Configuring MIMO Measurement Setups

The MIMO settings contain settings to configure a MIMO test setup and control the instruments in that test setup.

The MIMO settings are part of the "Analyzer Config / MIMO Setup" tab of the "General Settings" dialog box.

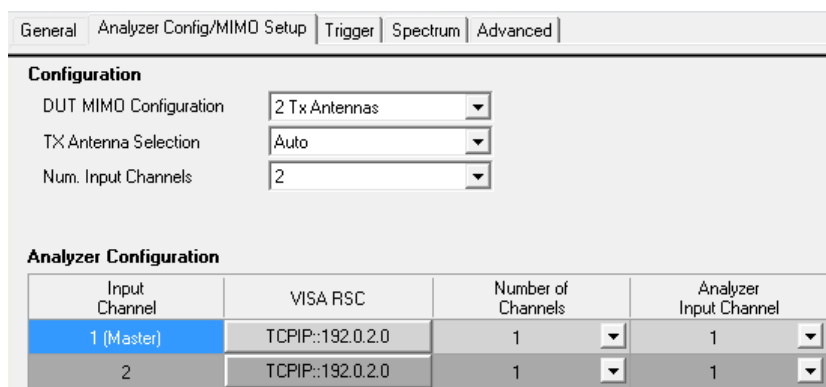

MIMO Configuration..... 79
 MIMO Analyzer Configuration..... 81

MIMO Configuration

The software supports measurements on DUTs with up to 8 antennas and is thus able to capture up to 8 I/Q data streams. You can select the number of antennas that transmit cell-specific reference signals (antenna ports AP 0 to 3) from the **"DUT MIMO Configuration"** dropdown menu.

The **"Tx Antenna Selection"** dropdown menu selects a particular antenna for evaluation. The number of items depends on the number of antennas you have selected in the "DUT MIMO Configuration" dropdown menu.

- "Antenna 1" corresponds to AP0
- "Antenna 2" corresponds to AP1
- "Antenna 3" corresponds to AP2
- "Antenna 4" corresponds to AP3
- If you select the "Auto" menu item, the software identifies which antennas transmit the cell-specific reference signals and selects them for the measurement.

The antenna you have selected is also the reference antenna for Time Alignment measurements.

Note that the "DUT MIMO Configuration" and the "Tx Antenna Selection" are the same as in the "Downlink Signal Characteristics" tab (→ "Demod Settings") - if you change them in one place, they are also changed in the other.

For more information on MIMO measurements see [chapter 8.4, "MIMO Measurement Guide"](#), on page 130.

The **"Num of Input Channels"** defines the number of I/Q streams to capture. The software allows you to record up to 8 I/Q data streams. You can capture the data from oscilloscope(s) or spectrum analyzer(s), or a combination of both. Depending on the number of input channels you have selected, the software adjusts the size of the **"Analyzer Configuration"** table.

Note: Time Alignment measurements with more than one carrier (→ [Carrier Aggregation](#)) also expand the size of the table, because more than one input channel is necessary for this task.

The number of input channels you have selected also affects the contents of the **"Antenna Selection"** dropdown menu (→ "General Settings" tab). A description is provided below ("Antenna (Port) Selection").

Selecting the "From Antenna Selection" menu item has the following effects.

- The number of used input channels depends on the number of antennas (→ "MIMO Configuration") and the "Tx Antenna Selection".
- The contents of the "Tx Antenna Selection" dropdown menu change. In addition to selecting a particular antenna, you can let the software decide which antenna(s) to test and in which order (→ "Auto 1 Antenna" etc.).

In case of automatic detection the software analyzes the reference signal(s) to select the antenna(s).

Displayed results for MIMO measurements

In the default state, each active result display shows the result for each input channel. Thus, the number of results corresponds to the **"Number of Input Channels"** you have selected. For example, if you have selected 4 input channels, the software would show 4 Constellation Diagrams.

Because this screen layout may make it difficult to read individual results, you have several options to increase the comfort of evaluating the results.

- Display one result display only (→ [Full screen mode](#))
- Open each result display in a separate window (→ "Open in Separate Window")
- Display the results for a particular stream of I/Q data only (→ [Antenna Selection](#), → "General" tab)
Note that a particular I/Q data stream may still contain information on several antenna ports.

Antenna (Port) Selection

In the [Antenna Selection](#) dropdown menu (→ "General" tab), the software allows you to select the antenna ports whose results are shown. Antenna port selection is possible only after the I/Q data has been already captured.

The contents of the dropdown menu depend on several parameters.

- the MIMO configuration (1, 2 or 4 antenna)
- the antenna selected for analysis
- the number of input channels
- the state of the CSI reference signal
- the state of the positioning reference signal
- the PDSCH MIMO precoding

The mapping of antenna ports to antenna is done by the software. Antennas that transmit a cell-specific reference signal (AP0 - AP3) are labeled "Tx1" to "Tx4". All other antennas are labeled "Tx BF" (beamforming).

Each menu item covers one or more antenna ports. The antenna ports are added and removed by the following rules.

- Antenna Port 0 - 3 (AP0 - AP3)
Available for analysis of antennas 1 to 4.
- Antenna Port 4 (AP4)
Analysis currently not supported.
- Antenna Port 5 (AP5)
Available for analysis of the UE specific reference signals.
- Antenna Port 6 (AP6)
Available for analysis if the [Positioning Reference Signal](#) is present.
- Antenna Port 7 - 14 (AP7 - AP14)
Available for analysis of UE-specific references.
- Antenna Port 15 - 22 (AP15 - AP22)
Available for analysis if the [CSI Reference Signal](#) is present.

Remote command:

DUT MIMO configuration:

[CONFigure\[:LTE\]:DL\[:CC<cci>\]:MIMO:CONFig](#) on page 208

TX antenna selection:

[CONFigure\[:LTE\]:DL\[:CC<cci>\]:MIMO:ASElection](#) on page 208

Number of input channels:

[CONFigure\[:LTE\]:NSources](#) on page 191

I/Q data stream selection:

[\[SENSe\]\[:LTE\]:SOURCE:SElect](#) on page 188

MIMO Analyzer Configuration

For a comprehensive description see [chapter 2.3, "Connecting the Computer to an Analyzer"](#), on page 19.

4.3 Triggering Measurements

The trigger settings contain settings that control triggered measurements.

You can select a trigger for any of the four possible analyzers in the measurement setup separately by selecting one of the analyzers from the dropdown menu next to the "Trigger Settings" label.

The trigger settings are part of the "General Settings" tab of the "General Settings" dialog box.

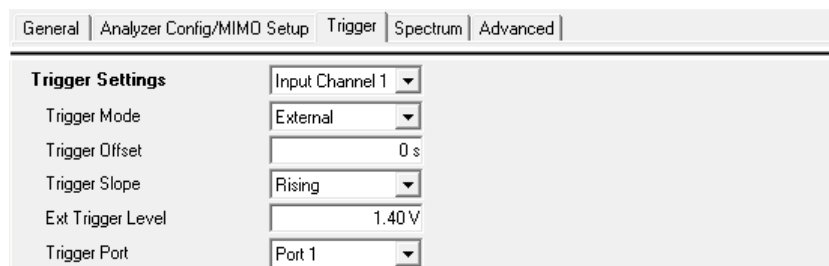

Trigger Settings	
Input Channel 1	Input Channel 1
Trigger Mode	External
Trigger Offset	0 s
Trigger Slope	Rising
Ext Trigger Level	1.40 V
Trigger Port	Port 1

Configuring the Trigger

A trigger allows you to capture those parts of the signal that you are really interested in.

While the software runs freely and analyzes all signal data in its default state, no matter if the signal contains information or not, a trigger initiates a measurement only under certain circumstances (the trigger event).

The software supports several **trigger modes** or sources.

- Free Run
Starts the measurement immediately and measures continuously.
- External
The trigger event is the level of an external trigger signal. The measurement starts when this signal meets or exceeds a specified trigger level at the "Ext Trigger/Gate" input.
Some measurement devices have several trigger ports. When you use one of these, you can additionally select the **trigger port** (1 to 3) you want to use.
- IF Power
The trigger event is the IF power level. The measurement starts when the IF power meets or exceeds a specified power trigger level.
- Trigger Unit FS-Z11
The R&S FS-Z11 is a trigger unit designed to control triggers in MIMO measurement setups.
Note that the trigger unit is not compatible with oscilloscope measurements.
For more information see ["Measurements with the R&S FS-Z11 trigger unit"](#) on page 134 and the documentation of the R&S FS-Z11.

You can define a **power level** for an external and an IF power trigger.

For most trigger sources you can select the **trigger slope**. The trigger slope defines whether triggering occurs when the signal rises to the trigger level or falls down to it.

The measurement starts as soon as the trigger event happens. It may become necessary to start the measurement some time after the trigger event. In that case, define a **trigger offset** (or trigger delay). The trigger offset is the time that should pass between the trigger event and the start of the measurement.

The trigger offset may be a negative time. The trigger offset is then called a **pretrigger**.

The trigger offset is available for all trigger modes, except free run.

Remote command:

For a comprehensive list of commands to define trigger characteristics see [chapter 9.7.3, "Using a Trigger"](#), on page 192.

4.4 Spectrum Settings

The spectrum settings contain settings to configure frequency sweep measurements (ACLR and SEM).

You can find the spectrum settings in the "General Settings" dialog box.

4.4.1 Configuring SEM and ACLR Measurements

The SEM (Spectrum Emission Mask) and ACLR (Adjacent Channel Leakage Ratio) settings contain settings that define aspects of those measurements.

The SEM and ACLR settings are part of the "Spectrum" tab of the "General Settings" dialog box.

The screenshot shows the 'Spectrum' tab of the 'General Settings' dialog box. The 'SEM and ACLR Settings' section is visible, containing the following controls:

- Category:** A dropdown menu set to 'Medium Range'.
- Assumed Adj. Channel Carrier:** A dropdown menu set to 'EUTRA same B'W'.
- ACLR Noise Correction:** An unchecked checkbox.
- Auto Gating:** A checked checkbox.
- TX Power:** A label, the text 'Auto', an unchecked checkbox, and a text input field containing '0.00 dBm'.

Category.....	82
Aggregated Maximum Power Of All TX Ports (P).....	83
TX Power.....	83
Assumed Adjacent Channel Carrier.....	83
Noise Correction.....	84
Auto Gating.....	84

Category

Selects the type, category and option of the limit definitions for SEM measurements.

The software supports limit definitions for the following types of base stations:

- Wide areas base stations (Category A and B)
- Local Area base stations
- Home base stations
- Medium Range base stations

Category A and B are defined in ITU-R recommendation SM.329. For Category B operating band unwanted emissions, there are two options for the limits that may be applied regionally (Opt1 and Opt2).

The type and category you should use for the measurement depends on the category and option that the base station you are testing supports.

For Home Area base stations, you can define an additional [Aggregated Maximum Power Of All TX Ports \(P\)](#) for all antenna ports of a home area base station. The aggregated maximum power is the aggregated power of all antenna ports and has an effect on the shape of the SEM.

For Medium Range base station, you can automatically measure or manually enter the power of the carrier [TX Power](#).

Remote command:

[\[SENSe\]:POWer:SEM:CAteGory](#) on page 194

Home BS power: [\[SENSe\]:POWer:SEM:CHBS:AMPower](#) on page 198

Medium BS power mode: [\[SENSe\]:POWer:SEM:CHBS:AMPower:AUTO](#) on page 194

Medium BS power value: [\[SENSe\]:POWer:SEM:CHBS:AMPower](#) on page 198

Aggregated Maximum Power Of All TX Ports (P)

Defines the aggregated maximum power of all TX ports of home base stations. The aggregate maximum power is required to calculate limit line values for SEM measurements on home base stations.

The parameter is available only if you have selected [SEM Category](#) "Home".

Remote command:

[\[SENSe\]:POWer:SEM:CHBS:AMPower](#) on page 198

TX Power

Turns automatic detection of the TX channel power for Medium Range base stations on and off.

When you turn this feature off, you can manually define the power of the transmission channel.

When you turn automatic detection of the power on, the software measures the power of the transmission channel.

The parameter is available only if you have selected [SEM Category](#) "Medium Range".

Remote command:

State: [\[SENSe\]:POWer:SEM:CHBS:AMPower:AUTO](#) on page 194

Power: [\[SENSe\]:POWer:SEM:CHBS:AMPower](#) on page 198

Assumed Adjacent Channel Carrier

Selects the assumed adjacent channel carrier for the ACLR measurement.

The supported types are EUTRA of same bandwidth, 1.28 Mcps UTRA, 3.84 Mcps UTRA and 7.68 Mcps UTRA.

Note that not all combinations of LTE Channel Bandwidth settings and Assumed Adj. Channel Carrier settings are defined in the 3GPP standard.

Remote command:

[\[SENSe\]:POWer:ACHannel:AACHannel](#) on page 195

Noise Correction

Turns noise correction on and off.

Note that the input attenuator makes a clicking noise after each sweep if you are using the noise correction in combination with the auto leveling process.

Remote command:

[\[SENSe\]:POWer:NCORrection](#) on page 195

Auto Gating

Turns gating for SEM and ACLR measurements on and off.

If on, the software evaluates the on-periods of an LTE TDD signal only. The software determines the location and length of the on-period from the "TDD UL/DL Allocations" and the "Configuration of the Special Subframe".

Note that the automatic cyclic prefix mode detection is not supported if you have turned on Auto Gating. In that case, you have to select the cyclic prefix mode manually.

Auto gating is available for TDD measurements in combination with an external or IF power trigger.

If you are using an external trigger, the DUT has to send an LTE frame trigger.

Remote command:

[\[SENSe\]:SWEep:EGATe:AUTO](#) on page 195

4.5 Advanced Settings

The advanced settings contain settings to configure the signal input and some global measurement analysis settings.

You can find the advanced settings in the "General Settings" dialog box.

- [Controlling I/Q Data](#).....84
- [Configuring the Baseband Input](#).....85
- [Using Advanced Input Settings](#).....86
- [Configuring the Digital I/Q Input](#).....86
- [Global Settings](#).....87
- [Mapping Antenna Ports](#).....88

4.5.1 Controlling I/Q Data

The I/Q settings contain settings that control the I/Q data flow.

The I/Q settings are part of the "Advanced" tab of the "General Settings" dialog box.

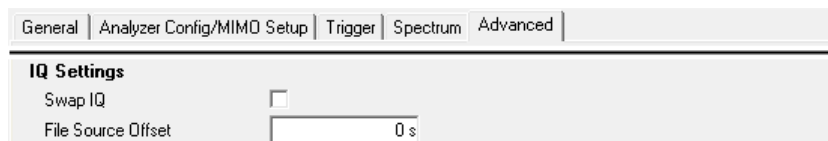

Swap I/Q..... 85
 File Source Offset..... 85

Swap I/Q

Swaps the real (I branch) and the imaginary (Q branch) parts of the signal.

Remote command:

[SENSe]:SWAPiQ on page 196

File Source Offset

Defines the location in an I/Q data file where the analysis starts.

Remote command:

INPut:IQ:FSoFFset on page 196

4.5.2 Configuring the Baseband Input

The baseband settings contain settings that configure the baseband input.

The baseband settings are part of the "Advanced" tab of the "General Settings" dialog box.

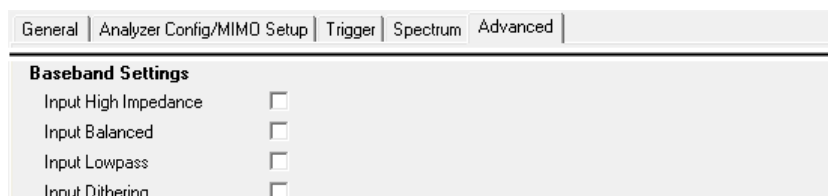

High Impedance..... 85
 Balanced..... 86
 Low Pass..... 86
 Dither..... 86

High Impedance

Selects the impedance of the baseband input.

By default (high impedance is off), the impedance is 50 Ω.

If you turn the high impedance on, the impedance changes to 1 kΩ or 1 MΩ, depending on the configuration of the analyzer.

High impedance is available for a baseband input source.

Remote command:

INPut:IQ:IMPedance on page 196

Balanced

Turns symmetric (or balanced) input on and off.

If active, a ground connection is not necessary. If you are using an asymmetrical (unbalanced) setup, the ground connection runs through the shield of the coaxial cable that is used to connect the DUT

Balancing is available for a baseband input source.

Remote command:

`INPut:IQ:BALanced[:STATe]` on page 197

Low Pass

Turns an anti-aliasing low pass filter on and off.

The filter has a cut-off frequency of 36 MHz and prevents frequencies above from being mixed into the usable frequency range. Note that if you turn the filter off, harmonics or spurious emissions of the DUT might be in the frequency range above 36 MHz and might be missed.

You can turn it off for measurement bandwidths greater than 30 MHz.

The low pass filter is available for a baseband input source.

Remote command:

`[SENSe]:IQ:LPASs[:STATe]` on page 197

Dither

Adds a noise signal into the signal path of the baseband input.

Dithering improves the linearity of the A/D converter at low signal levels or low modulation. Improving the linearity also improves the accuracy of the displayed signal levels.

The signal has a bandwidth of 2 MHz with a center frequency of 38.93 MHz.

Dithering is available for a baseband input source.

Remote command:

`[SENSe]:IQ:DITHer[:STATe]` on page 197

4.5.3 Using Advanced Input Settings

The advanced input settings contain settings that configure the RF input.

The advanced input settings are part of the "Advanced" tab of the "General Settings" dialog box.

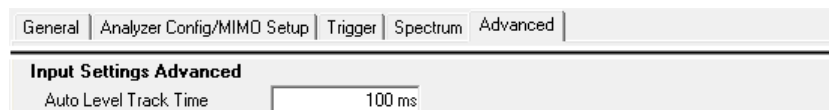

For more information see ["Defining a Reference Level"](#) on page 71.

4.5.4 Configuring the Digital I/Q Input

The digital I/Q settings contain settings that configure the digital I/Q input.

The digital I/Q settings are part of the "Advanced" tab of the "General Settings" dialog box.

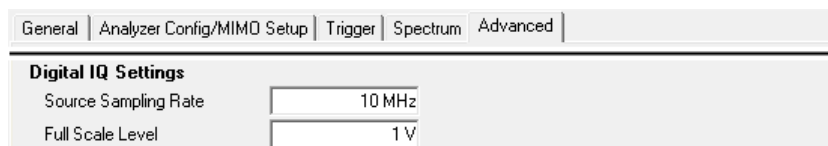

Sampling Rate (Input Data Rate)..... 87
 Full Scale Level..... 87

Sampling Rate (Input Data Rate)

Defines the data sample rate at the digital baseband input.

The sample rate is available for a digital baseband input source.

Remote command:

[INPut<n>:DIQ:SRATe](#) on page 198

Full Scale Level

Defines the voltage corresponding to the maximum input value of the digital baseband input.

Remote command:

[INPut<n>:DIQ:RANGe\[:UPPer\]](#) on page 198

4.5.5 Global Settings

The global settings contain settings that are independent of other settings.

The global settings are part of the "Advanced" tab of the "General Settings" dialog box.



Couple Screens..... 87
 Stop Run Continuous On Limit Check Fail..... 87

Couple Screens

Couples and decouples markers that have the same x-axis unit in the top and bottom result displays (e.g. both result displays have a frequency axis).

In case of the constellation diagram, the constellation selection is also coupled to the marker.

Stop Run Continuous On Limit Check Fail

Stops a continuous measurement if the signal fails any limit check in the currently active result display.

For example, the measurement would stop on an EVM PDSCH QPSK limit check fail if the result summary is active.

4.5.6 Mapping Antenna Ports

The antenna port mapping settings contain settings that map antenna ports to a specific input channel.

The antenna port mapping settings are part of the "Advanced" tab of the "General Settings" dialog box.



[Input Channel 1 UE/CSI-RS Antenna Port](#).....88

Input Channel 1 UE/CSI-RS Antenna Port

Selects the (beamforming) antenna port that is measured on the first I/Q data stream. The first I/Q data stream corresponds to input channel 1.

By default, the software automatically assigns the antenna port to the input channel. To assign a specific antenna port to the first input channel, select the required antenna port from the dropdown menu.

Assigning the antenna port to the input channel is necessary to measure the EVM for all available UE / CSI-RS antenna ports. When you perform a measurement on a MIMO signal with more than one I/Q streams, the remaining antenna ports are assigned in ascending order to the inputs.

Remote command:

[CONFigure\[:LTE\]:DL\[:CC<cci>\]:MIMO:SUAP](#) on page 199

5 Demod Settings

The following chapter contains all settings that are available in the "Demodulation Settings" dialog box.

- [Configuring Downlink Signal Demodulation](#)..... 89
- [Defining Downlink Signal Characteristics](#)..... 95
- [Defining Advanced Signal Characteristics](#)..... 105
- [Defining MBSFN Characteristics](#)..... 116

5.1 Configuring Downlink Signal Demodulation

The downlink demodulation settings contain settings that describe the signal processing and the way the signal is measured.

You can find the demodulation settings in the "Demod Settings" dialog box.

- [Selecting the Demodulation Method](#)..... 89
- [Configuring Multicarrier Base Stations](#)..... 90
- [Configuring Parameter Estimation](#)..... 91
- [Compensating Signal Errors](#)..... 91
- [Configuring EVM Measurements](#)..... 92
- [Processing Demodulated Data](#)..... 93
- [Configuring MIMO Setups](#)..... 94

5.1.1 Selecting the Demodulation Method

The PDSCH demodulation settings contain settings that describe the way the PDSCH is demodulated during measurements.

The demodulation settings are part of the "Downlink Demodulation Settings" tab of the "Demodulation Settings" dialog box.

Downlink Demodulation Settings	Downlink Signal Characteristics	Downlink Advanced Signal Characteristics
Demodulation		
Auto PDSCH Demodulation <input type="checkbox"/>		
PDSCH Subframe Configuration Detection <input type="text" value="Physical Detection"/>		

- [Auto PDSCH Demodulation](#)..... 89
- [PDSCH Subframe Configuration Detection](#)..... 90

Auto PDSCH Demodulation

Turns automatic demodulation of the PDSCH on and off.

When you turn this feature on, the software automatically detects the PDSCH resource allocation. This is possible by analyzing the protocol information in the PDCCH or by analyzing the physical signal. The software then writes the results into the [PDSCH Configuration Table](#).

You can set the way the software identifies the PDSCH resource allocation with "[PDSCH Subframe Configuration Detection](#)" on page 90.

When you turn off automatic demodulation of the PDSCH, you have to configure the PDSCH manually. In that case, the software compares the demodulated LTE frame to the customized configuration. If the [PDSCH Subframe Configuration Detection](#) is not turned off, the software analyzes the frame only if both configurations are the same.

Remote command:

[\[SENSe\] \[:LTE\]:DL:DEMod:AUTO](#) on page 200

PDSCH Subframe Configuration Detection

Selects the method of identifying the PDSCH resource allocation.

- Off
Uses the user configuration to demodulate the PDSCH subframe. If the user configuration does not match the frame that was measured, a bad EVM will result.
- PDCCH protocol
Sets the PDSCH configuration according to the data in the protocol of the PDCCH DCIs.
When you use this method, the software measures the boosting for each PDCCH it has detected. The result is displayed in the [Channel Decoder Results](#).
- Physical detection
The physical detection is based on power and modulation detection.
Physical detection makes measurements on TDD E-TMs without a 20 ms trigger signal possible.
For more information on automatic demodulation see "[Auto PDSCH Demodulation](#)" on page 89.

Remote command:

[\[SENSe\] \[:LTE\]:DL:FORMat:PSCD](#) on page 200

5.1.2 Configuring Multicarrier Base Stations

The multicarrier base station settings contain settings to configure measurements on multicarrier base stations.

The multicarrier base station settings are part of the "Downlink Demodulation Settings" tab of the "Demodulation Settings" dialog box.

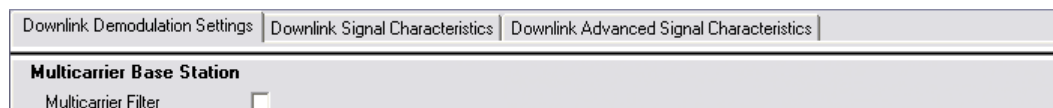

[Multicarrier Filter](#)..... 90

Multicarrier Filter

Turns the suppression of interference of neighboring carriers for tests on multiradio base stations on and off (e.g. LTE, WCDMA, GSM etc).

Remote command:

[\[SENSe\] \[:LTE\]:DL:DEMod:MCFilter](#) on page 201

5.1.3 Configuring Parameter Estimation

The parameter estimation settings contain settings that estimate various parameters during the measurement.

The parameter estimation settings are part of the "Downlink Demodulation Settings" tab of the "Demodulation Settings" dialog box.



Boosting Estimation	91
Channel Estimation	91

Boosting Estimation

Turns boosting estimation on and off.

When you turn this feature on, the software automatically sets the relative power settings of all physical channels and the P-/S-SYNC by analyzing the signal.

Remote command:

[\[SENSe\] \[:LTE\]:DL:DEMod:BEStimation](#) on page 201

Channel Estimation

Selects the method of channel estimation.

- **EVM 3GPP Definition**
Channel estimation according to 3GPP TS 36.141. This method is based on averaging in frequency direction and linear interpolation. Examines the reference signal only.
- **Optimal, Pilot only**
Optimal channel estimation method. Examines the reference signal only.
- **Optimal, Pilot and Payload**
Optimal channel estimation method. Examines both the reference signal and the payload resource elements.

Remote command:

[\[SENSe\] \[:LTE\]:DL:DEMod:CEStimation](#) on page 201

5.1.4 Compensating Signal Errors

The tracking settings contain settings that compensate for various common signal errors that may occur.

The tracking settings are part of the "Downlink Demodulation Settings" tab of the "Demodulation Settings" dialog box.

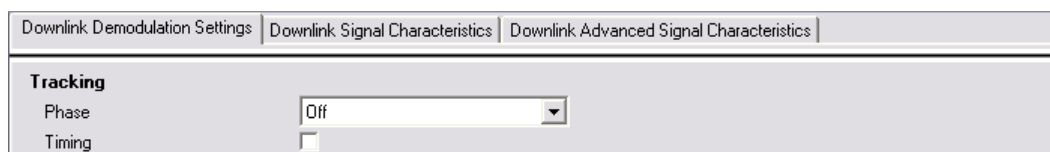

Phase..... 92
 Timing..... 92

Phase

Specifies whether or not the measurement results should be compensated for common phase error. When phase compensation is used, the measurement results will be compensated for phase error on a per-symbol basis.

- "Off" Phase tracking is not applied.
- "Pilot Only" Only the reference signal is used for the estimation of the phase error.
- "Pilot and Payload" Both reference signal and payload resource elements are used for the estimation of the phase error.

Remote command:

[SENSe] [:LTE] :DL:TRACking:PHASe on page 202

Timing

Specifies whether or not the measurement results should be compensated for timing error. When timing compensation is used, the measurement results will be compensated for timing error on a per-symbol basis.

Remote command:

[SENSe] [:LTE] :DL:TRACking:TIME on page 202

5.1.5 Configuring EVM Measurements

The demodulation EVM settings contain settings that control the way the software calculates EVM results.

The demodulation EVM settings are part of the "Downlink Demodulation Settings" tab of the "Demodulation Settings" dialog box.



EVM Calculation Method..... 92
 PDSCH Reference Data..... 93

EVM Calculation Method

Selects the method to calculate the EVM.

- **EVM 3GPP Definition**
 Calculation of the EVM according to 3GPP TS 36.141. Evaluates the EVM at two trial timing positions and then uses the maximum EVM of the two.

- **At Optimal Timing Position**

Calculates the EVM using the optimal timing position.

Remote command:

[SENSe] [:LTE]:DL:DEMod:EVMCalc on page 202

PDSCH Reference Data

Selects the type of reference data to calculate the EVM for the PDSCH.

- Auto detect
Automatically identifies the reference data for the PDSCH by analyzing the signal.
- All 0 (E-TM)
Sets the PDSCH reference data to a fixed value of 0. This value is according to the test model definition.
To get valid results, you have to use a DUT that transmits an all-zero data vector.
This setting is a good way if you are expecting signals with a high EVM because the automatic detection will not be reliable in that case.

Remote command:

[SENSe] [:LTE]:DL:DEMod:PRData on page 202

5.1.6 Processing Demodulated Data

The demodulated data settings contain settings that control the way the software handles demodulated data.

The demodulated data settings are part of the "Downlink Demodulation Settings" tab of the "Demodulation Settings" dialog box.



Scrambling of Coded Bits.....93
 Decode All Channels.....94

Scrambling of Coded Bits

Turns the scrambling of coded bits for all physical channels like PDSCH or PHICH on and off.

The scrambling of coded bits affects the bitstream results.

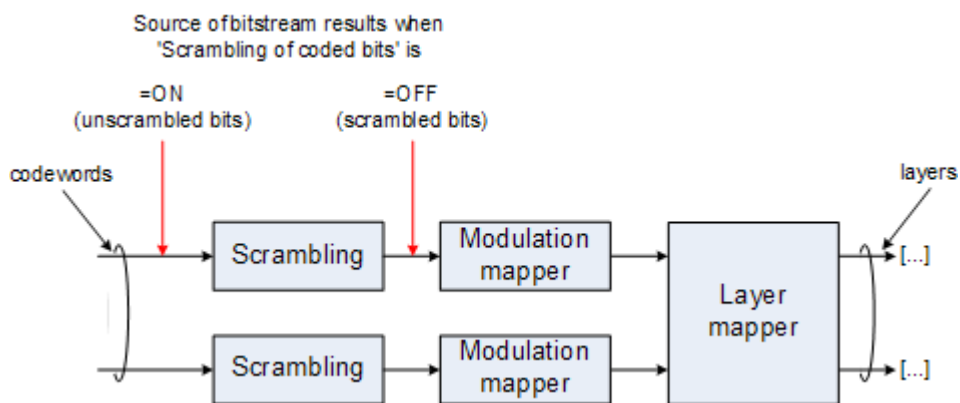

Fig. 5-1: Source for bitstream results if scrambling for coded bits is on and off

Remote command:

[SENSe] [:LTE] :DL:DEMod:CBSCrambling on page 203

Decode All Channels

Turns the decoding of all physical channels on and off.

When you turn this feature on, the software shows the decoding results in the "Channel Decoder Results" result display.

In addition, the software only measures the EPDCCH resource block that are actually used.

When you turn the feature off,

- the PBCH is decoded only if the PHICH Duration or the PHICH N_g are automatically determined
- the PDCCH is decoded only if the PDSCH Subframe Configuration Detection is set to PDCCH protocol.

If decoding of all control channels is off, measurement speed will increase.

Remote command:

[SENSe] [:LTE] :DL:DEMod:DACHannels on page 203

5.1.7 Configuring MIMO Setups

The MIMO settings contain settings that configure MIMO measurement setups.

The MIMO settings are part of the "Downlink Demodulation Settings" tab of the "Demodulation Settings" dialog box.

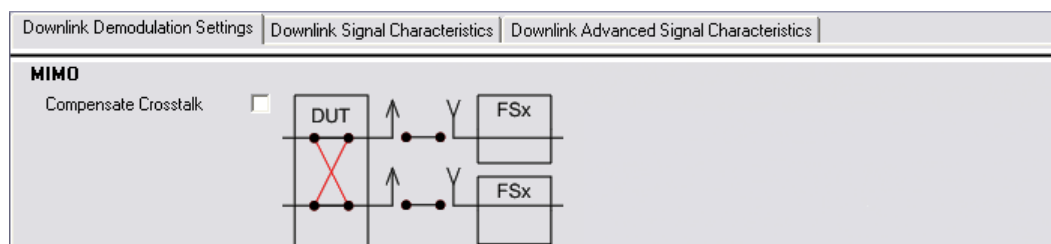

Compensate Crosstalk.....95

Compensate Crosstalk

Turns compensation of crosstalk produced by one of the components in the test setup on and off.

Turn this feature on, if you expect crosstalk from the DUT or another component in the test setup. This may be necessary, for example, for over-the-air measurements.

If you connect the DUT to the analyzer by cable, turn off crosstalk compensation. In that case, the only crosstalk results from the DUT itself and contributes as distortion to the measurement results.

Remote command:

`CONFigure[:LTE]:DL:MIMO:CROStalk` on page 203

5.2 Defining Downlink Signal Characteristics

The downlink signal characteristics contain settings to describe the physical attributes and structure of a downlink LTE signal.

You can find the signal characteristics in the "Demod Settings" dialog box.

For more information on the "MIMO Configuration" see "[MIMO Configuration](#)" on page 79.

- [Defining the Physical Signal Characteristics](#).....95
- [Configuring the Physical Layer Cell Identity](#).....97
- [Configuring MIMO Measurements](#).....98
- [Configuring PDSCH Subframes](#).....99

5.2.1 Defining the Physical Signal Characteristics

The physical signal characteristics contain settings to describe the physical attributes of a downlink LTE signal.

The physical settings are part of the "Downlink Signal Characteristics" tab of the "Demodulation Settings" dialog box.

Downlink Demodulation Settings		Downlink Signal Characteristics		Downlink Advanced Signal Characteristics	
Physical Settings					
Channel Bandwidth	3 MHz (15 RB)	Sampling Rate	3.84 MHz	Occupied BW	2.715 MHz
Cyclic Prefix	Auto	FFT Size	256	Occupied Carriers	181
TDD UL/DL Allocations	Conf. 0	TDD Allocations	DL,S,UL,UL,UL	DL,S,UL,UL,UL	
Conf. of Special Subframe	Conf. 0				

Channel Bandwidth / Number of Resource Blocks

Specifies the channel bandwidth and number of resource blocks (RB).

The channel bandwidth and number of resource blocks (RB) are interdependent. Currently, the LTE standard recommends six bandwidths (see table below).

The software also calculates the FFT size, sampling rate, occupied bandwidth and occupied carriers from the channel bandwidth. Those are read only.

Channel Bandwidth [MHz]	1.4	3	5	10	15	20
Number of Resource Blocks	6	15	25	50	75	100
Sample Rate [MHz]	1.92	3.84	7.68	15.36	30.72	30.72
FFT Size	128	256	512	1024	2048	2048

The software shows the currently selected LTE mode (including the bandwidth) in the header table.

Freq 1 GHz	CP/Cell ID E
Mode UL TDD, 10 MHz	Sync State -

Remote command:

[CONFigure\[:LTE\]:DL\[:CC<cci>\]:BW](#) on page 204

Cyclic Prefix

The cyclic prefix serves as a guard interval between OFDM symbols to avoid interferences. The standard specifies two cyclic prefix modes with a different length each.

The cyclic prefix mode defines the number of OFDM symbols in a slot.

- Normal
A slot contains 7 OFDM symbols.
- Extended
A slot contains 6 OFDM symbols.
The extended cyclic prefix is able to cover larger cell sizes with higher delay spread of the radio channel.
- Auto
The application automatically detects the cyclic prefix mode in use.

The software shows the currently selected cyclic prefix in the header table.

CP/Cell ID Extended/Cell ID 190	Mas
Sync State --	Cap

Remote command:

[CONFigure\[:LTE\]:DL\[:CC<cci>\]:CYCPrefix](#) on page 204

Configuring TDD Frames

TDD frames contain both uplink and downlink information separated in time with every subframe being responsible for either uplink or downlink transmission. The standard specifies several subframe configurations or resource allocations for TDD systems.

TDD UL/DL Allocations

Selects the configuration of the subframes in a radio frame in TDD systems.

The UL/DL configuration (or allocation) defines the way each subframe is used: for uplink, downlink or if it is a special subframe. The standard specifies seven different configurations.

Configuration	Subframe Number and Usage									
	0	1	2	3	4	5	6	7	8	9
0	D	S	U	U	U	D	S	U	U	U
1	D	S	U	U	D	D	S	U	U	D
2	D	S	U	D	D	D	S	U	D	D
3	D	S	U	U	U	D	D	D	D	D
4	D	S	U	U	D	D	D	D	D	D
5	D	S	U	D	D	D	D	D	D	D
6	D	S	U	U	U	D	S	U	U	D

U = uplink
D = downlink
S = special subframe

Conf. of Special Subframe

In combination with the cyclic prefix, the special subframes serve as guard periods for switches from uplink to downlink. They contain three parts or fields.

- DwPTS
The DwPTS is the downlink part of the special subframe. It is used to transmit downlink data.
- GP
The guard period makes sure that there are no overlaps of up- and downlink signals during a switch.
- UpPTS
The UpPTS is the uplink part of the special subframe. It is used to transmit uplink data.

The length of the three fields is variable. This results in several possible configurations of the special subframe. The LTE standard defines 10 different configurations for the special subframe. However, configurations 8 and 9 only work for a normal cyclic prefix.

If you select configurations 8 or 9 using an extended cyclic prefix or automatic detection of the cyclic prefix, the software will show an error message.

Remote command:

Subframe: `CONFigure[:LTE]:DL[:CC<cci>]:TDD:UDConf` on page 205

Special subframe: `CONFigure[:LTE]:DL[:CC<cci>]:TDD:SPSC` on page 205

5.2.2 Configuring the Physical Layer Cell Identity

The physical signal characteristics contain settings to describe the physical attributes of a downlink LTE signal.

The physical settings are part of the "Downlink Signal Characteristics" tab of the "Demodulation Settings" dialog box.

The screenshot shows the 'Downlink Signal Characteristics' tab of the 'Demodulation Settings' dialog box. Under the 'Physical Layer Cell Identity' section, there is an 'Auto' checkbox which is unchecked. To its right are three input fields: 'Cell ID' containing the value '0', 'Cell Identity Group' containing the value '0', and 'Identity' containing the value '0'.

Configuring the Physical Layer Cell Identity

The cell ID, cell identity group and physical layer identity are interdependent parameters. In combination they are responsible for synchronization between network and user equipment.

The physical layer cell ID identifies a particular radio cell in the LTE network. The cell identities are divided into 168 unique cell identity groups. Each group consists of 3 physical layer identities. According to

$$N_{ID}^{cell} = 3 \cdot N_{ID}^{(1)} + N_{ID}^{(2)}$$

$N^{(1)}$ = cell identity group, {0...167}

$N^{(2)}$ = physical layer identity, {0...2}

there is a total of 504 different cell IDs.

If you change one of these three parameters, the software automatically updates the other two.

For automatic detection of the cell ID, turn the "Auto" function on.

Before it can establish a connection, the user equipment must synchronize to the radio cell it is in. For this purpose, two synchronization signals are transmitted on the downlink. These two signals are reference signals whose content is defined by the "Physical Layer Identity" and the "Cell Identity Group".

The first signal is one of 3 possible Zadoff-Chu sequences. The sequence that is used is defined by the physical layer identity. It is part of the P-SYNC.

The second signal is one of 168 unique sequences. The sequence is defined by the cell identity group. This sequence is part of the S-SYNC.

In addition to the synchronization information, the cell ID also determines

- the cyclic shifts for PCFICH, PHICH and PDCCH mapping,
- the frequency shifts of the reference signal.

The software shows the currently selected cell ID in the header table.

CP/Cell ID	Extended/Cell ID 190	Mag
Sync State	---	Cap

Remote command:

Cell ID: [CONFigure\[:LTE\]:DL\[:CC<cci>\]:PLC:CID](#) on page 206

Cell Identity Group (setting): [CONFigure\[:LTE\]:DL\[:CC<cci>\]:PLC:CIDGroup](#) on page 207

Cell Identity Group (query): [FETCh\[:CC<cci>\]:PLC:CIDGroup?](#) on page 207

Identity (setting): [CONFigure\[:LTE\]:DL\[:CC<cci>\]:PLC:PLID](#) on page 207

Identity (query): [FETCh\[:CC<cci>\]:PLC:PLID?](#) on page 208

5.2.3 Configuring MIMO Measurements

The "DUT MIMO Configuration" and the "Tx Antenna Selection" are the same as in the "Analyzer Config / MIMO Setup" tab (→ "General Settings") - if you change them in one place, they are also changed in the other.

For more information see ["MIMO Configuration"](#) on page 79.

5.2.4 Configuring PDSCH Subframes

The software allows you to configure individual subframes that are used to carry the information of the PDSCH. The PDSCH (Physical Downlink Shared Channel) primarily carries all general user data. It therefore takes up most of the space in a radio frame.

When you turn "Auto Demodulation" on, the software automatically determines the subframe configuration for the PDSCH. In the default state, automatic configuration is on (see "Auto PDSCH Demodulation" on page 89).

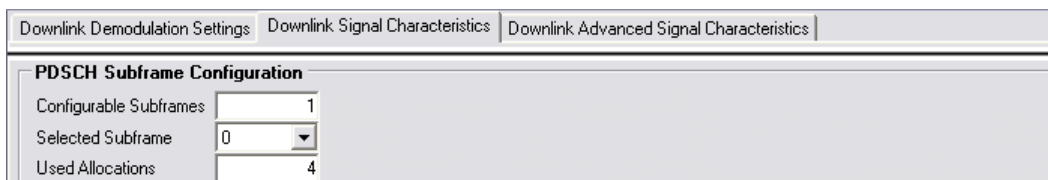

Every LTE frame (FDD and TDD) contains 10 subframes. (In TDD systems, some subframes are used by the uplink, however.) Each downlink subframe consists of one or more (resource) allocations. The software shows the contents for each subframe in the configuration table. In the configuration table, each row corresponds to one allocation.

	ID / N_RNTI	Code Word	Modulation	Enhanced Settings	VRB Gap	Number of RB	Offset RB	Rho A (Power)/dB
▶	0	1/1	16QAM	...	0	4	6	0
	1	1/1	16QAM	...	0	2	10	0
	2	1/1	16QAM	...	0	4	0	0
	3	1/1	16QAM	...	0	2	4	0



Subframe configuration errors

If there are any errors or conflicts between allocations in one or more subframes, the software shows a  icon in the column at the left of the table.

When you move the mouse over the icon, the software shows the kind of error.

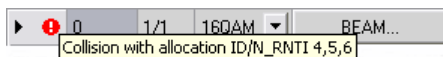

Before you start to work on the contents of each subframe, you should define the number of subframes you want to customize with the "Configurable Subframes" parameter. The software supports the configuration of up to 40 subframes.

Then you can select a particular subframe that you want to customize in the "Selected Subframe" field. Enter the number of the subframe (starting with 0). The software updates the contents of the configuration table to the selected subframe.

Remote command:

Number of subframes: `CONFigure[:LTE]:DL:CSUBframes` on page 209

Number of allocations: `CONFigure[:LTE]:DL:SUBFrame<subframe>:ALCount` on page 209

- [PDSCH Allocations](#)..... 100
- [Enhanced Settings](#)..... 102

5.2.4.1 PDSCH Allocations

In the default state, each subframe contains one allocation. Add allocations with the "Used Allocations" parameter. The software expands the configuration table accordingly with one row representing one allocation. You can define a different number of allocations for each subframe you want to configure and configure up to 110 allocations in every subframe.

The configuration table contains the settings to configure the allocations.

ID/N_RNTI.....	100
Code Word.....	100
Modulation.....	100
Enhanced Settings.....	101
VRB Gap.....	101
Number of RB.....	101
Offset RB.....	101
Power.....	102
Conflict.....	102

ID/N_RNTI

Selects the allocation's ID. The ID corresponds to the N_RNTI.

By default, the software assigns consecutive numbers starting with 0.

The ID, or N_RNTI, is the user equipment identifier for the corresponding allocation and is a number in the range from 0 to 65535. The order of the numbers is irrelevant. You can combine allocations by assigning the same number more than once. Combining allocations assigns those allocations to the same user. Allocations with the same N_RNTI share the same modulation scheme and power settings.

Remote command:

```
CONFigure[:LTE]:DL:SUBFrame<subframe>:ALLoc<allocation>:UEID
on page 210
```

Code Word

Shows the code word of the allocation.

The code word is made up out of two numbers. The first number is the number of the code word in the allocation. The second number is the total number of code words that the allocation contains. Thus, a table entry of "1/2" would mean that the row corresponds to code word 1 out of 2 code words in the allocation.

Usually one allocation corresponds to one code word. In case of measurements on a MIMO system (2 or 4 antennas) in combination with the "Spatial Multiplexing" precoding value, however, you can change the number of layers. Selecting 2 or more layers assigns two code words to the allocation. This results in an expansion of the configuration table. The allocation with the spatial multiplexing then comprises two rows instead of only one. Except for the modulation of the code word, which can be different, the contents of the second code word (row) are the same as the contents of the first code word.

Modulation

Selects the modulation scheme for the corresponding allocation.

The modulation scheme for the PDSCH is either QPSK, 16QAM, 64QAM or 256QAM.

Remote command:

```
CONFigure[:LTE]:DL:SUBFrame<subframe>:ALLoc<allocation>[:  
CW<Cwnum>]:MODulation on page 210
```

Enhanced Settings

Opens a dialog box to configure MIMO functionality.

For more information see [chapter 5.2.4.2, "Enhanced Settings"](#), on page 102.

VRB Gap

Turns the use of virtual resource blocks (VRB) on and off.

The standard defines two types of VRBs. Localized VRBs and distributed VRBs. While localized VRBs have a direct mapping to the PRBs, distributed VRBs result in a better frequency diversity.

Three values of VRB gap are allowed.

- **0** = Localized VRBs are used.
- **1** = Distributed VRBs are used and the first gap is applied.
- **2** = Distributed VRBs are used and the second gap is applied (for channel bandwidths > 50 resource blocks).

The second gap has a smaller size compared to the first gap.

If on, the VRB Gap determines the distribution and mapping of the VRB pairs to the physical resource blocks (PRB) pairs.

The distribution of the VRBs is performed in a way that consecutive VRBs are spread over the frequencies and are not mapped to PRBs whose frequencies are next to each other. Each VRB pair is split into two parts which results in a frequency gap between the two VRB parts. This method corresponds to frequency hopping on a slot basis.

The information whether localized or distributed VRBs are applied is carried in the PDCCH. The DCI formats 1A, 1B and 1D provide a special 1-bit flag for this purpose ("Localized / Distributed VRB Assignment"). Another bit in the DCI formats controls whether the first or second bit is applied.

Remote command:

```
CONFigure[:LTE]:DL:SUBFrame<subframe>:ALLoc<allocation>:GAP  
on page 210
```

Number of RB

Defines the number of resource blocks the allocation covers. The number of resource blocks defines the size or bandwidth of the allocation.

If you allocate too many resource blocks compared to the bandwidth you have set. the software will show a  icon in the column at the left of the table.

Remote command:

```
CONFigure[:LTE]:DL:SUBFrame<subframe>:ALLoc<allocation>:RBCount  
on page 213
```

Offset RB

Sets the resource block at which the allocation begins.

A wrong offset for any allocation would lead to an overlap of allocations. In that case the software will show an error message.

Remote command:

`CONFigure[:LTE]:DL:SUBFrame<subframe>:ALLoc<allocation>:RBOffset`
on page 213

Power

Sets the boosting of the allocation. Boosting is the allocation's power relative to the reference signal power.

Remote command:

`CONFigure[:LTE]:DL:SUBFrame<subframe>:ALLoc<allocation>:POWER`
on page 211

Conflict

Move the mouse over the  icon to see details on the conflict. Possible conflicts are:

- Allocation exceeds available bandwidth
A bandwidth error occurs when the number of resource blocks in the subframe exceeds the bandwidth you have set.

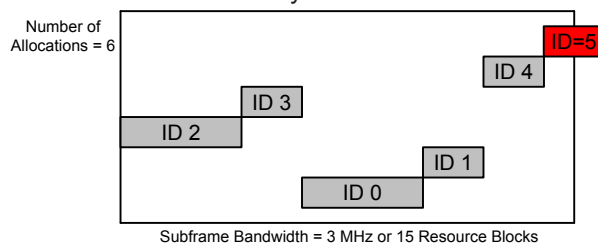

- Collision with allocation
An RB overlap error occurs if one or more allocations overlap. In that case, check if the length and offset values of the allocations are correct.

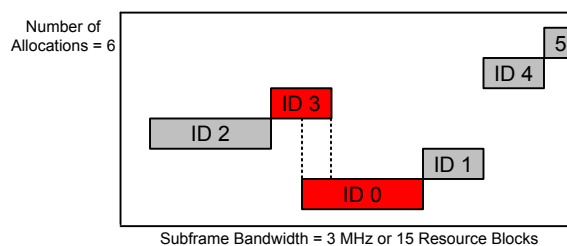

5.2.4.2 Enhanced Settings

The "Enhanced Settings" contain mostly functionality to configure the precoding scheme of a physical channel. The software supports several precoding schemes that you can select from a dropdown menu.

In addition, you can configure PDSCH allocations that use carrier aggregation.

Precoding

None.....	103
Transmit Diversity.....	103
Spatial Multiplexing.....	103
Beamforming (UE Spec RS).....	104
Carrier Aggregation.....	105

None

Turns off precoding.

Remote command:

CONFigure[:LTE]:DL:SUBFrame<subframe>:ALLoc<allocation>:

PRECoding[:SCHeme] on page 212

Transmit Diversity

Turns on precoding for transmit diversity according to 3GPP TS 36.211.

Remote command:

CONFigure[:LTE]:DL:SUBFrame<subframe>:ALLoc<allocation>:

PRECoding[:SCHeme] on page 212

Spatial Multiplexing

Turns on precoding for spatial multiplexing according to 3GPP TS 36.211.

If you are using spatial multiplexing, you can also define the number of layers for any allocation and the codebook index.

The number of layers of an allocation in combination with the number of code words determines the layer mapping. The available number of layers depends on the number of transmission antennas. Thus, the maximum number of layers you can select is eight.

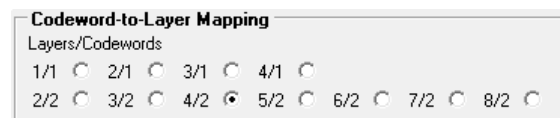

The codebook index determines the precoding matrix. The available number of indices depends on the number of transmission antennas in use. The range is from 0 to 15. The software automatically selects the codebook index if you turn the "Cyclic Delay Diversity" (CDD) on.

Spatial Multiplexing Settings

Codebook Index

0 1 2 3 4 5 6 7

8 9 10 11 12 13 14 15

Cyclic Delay Diversity (CDD)

Remote command:

`CONFigure[:LTE]:DL:SUBFrame<subframe>:ALLoc<allocation>:PRECoding[:SCHeme]` on page 212

`CONFigure[:LTE]:DL:SUBFrame<subframe>:ALLoc<allocation>:PRECoding:CLMapping` on page 211

`CONFigure[:LTE]:DL:SUBFrame<subframe>:ALLoc<allocation>:PRECoding:CBINdex` on page 211

`CONFigure[:LTE]:DL:SUBFrame<subframe>:ALLoc<allocation>:PRECoding:CDD` on page 212

Beamforming (UE Spec RS)

Turns on the precoding for beamforming.

If you are using beamforming, you can also define the number of layers and code-words (see [Spatial Multiplexing](#)), the scrambling identity and the single layer antenna port.

The mapping of antenna port to the physical antenna is fixed:

- Port 5 and 7: Antenna 1
- Port 8: Antenna 2
- Port 9: Antenna 3
- Port 10: Antenna 4

Beamforming Settings

Scrambling Identity n_{SCID} 0 1

Single Layer Antenna Port

The scrambling identity (n_{SCID}) is available for antenna ports 7 and 8. It is used to initialize the sequence that generates UE specific reference signals according to 36.211 (section 6.10.3.1).

The single layer antenna port selects the preconfigured antenna port in single layer beamforming scenarios. Available if the codeword to layer mapping is "1/1".

Remote command:

`CONFigure[:LTE]:DL:SUBFrame<subframe>:ALLoc<allocation>:PRECoding[:SCHeme]` on page 212

`CONFigure[:LTE]:DL:SUBFrame<subframe>:ALLoc<allocation>:PRECoding:CLMapping` on page 211

`CONFigure[:LTE]:DL:SUBFrame<subframe>:ALLoc<allocation>:PRECoding:SCID` on page 212

`CONFigure[:LTE]:DL:SUBFrame<subframe>:ALLoc<allocation>:PRECoding:AP` on page 211

Carrier Aggregation

Defines the PDSCH start offset for the selected PDSCH allocation in a system that uses carrier aggregation.

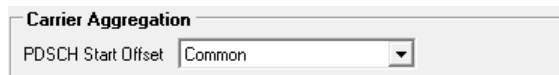

For cross-scheduled UEs, the PDSCH start offset for the secondary carrier is usually not defined for each subframe individually but is constant over several subframes. In case the control channel region of the secondary component carrier is longer than the PDSCH start offset you have defined for the primary carrier, PDSCH resource elements might be overwritten by the resource elements of the control channel. Note that the bit stream result displays labels these resource element with a "#" sign.

Remote command:

`CONFigure [:LTE] :DL:SUBFrame<subframe>:ALLoc<allocation>:PSOffset`
on page 213

5.3 Defining Advanced Signal Characteristics

The downlink advanced signal characteristics contain settings that describe the detailed structure of a downlink LTE signal.

You can find the advanced signal characteristics in the "Demod Settings" dialog box.

- [Configuring the Synchronization Signal](#)..... 105
- [Configuring the Reference Signal](#)..... 106
- [Configuring Positioning Reference Signals](#)..... 106
- [Configuring Channel State Information Reference Signal](#)..... 108
- [Defining the PDSCH Resource Block Symbol Offset](#).....110
- [Configuring the Control Channels](#)..... 110
- [Configuring the Shared Channel](#)..... 115

5.3.1 Configuring the Synchronization Signal

The synchronization signal settings contain settings to describe the physical attributes and structure of the synchronization signal.

The synchronization signal settings are part of the "Downlink Advanced Signal Characteristics" tab of the "Demodulation Settings" dialog box.

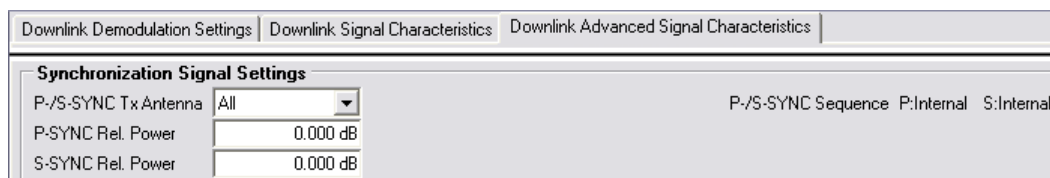

- [P-/S-SYNC Tx Antenna](#)..... 106
- [P-SYNC Relative Power](#)..... 106
- [S-SYNC Relative Power](#)..... 106

P-/S-SYNC Tx Antenna

Selects the antenna that transmits the synchronization signal (P-SYNC or S-SYNC).

When selecting the antenna, you implicitly select the synchronization method. If the selected antenna transmits no synchronization signal, the software uses the reference signal to synchronize. Note that automatic cell ID detection is not available if synchronization is based on the reference signal.

Remote command:

`CONFigure[:LTE]:DL[:CC<cci>]:SYNC:ANTenna` on page 214

P-SYNC Relative Power

Defines the power of the primary synchronization signal (P-SYNC) relative to the reference signal.

Remote command:

`CONFigure[:LTE]:DL:SYNC:PPOwer` on page 214

S-SYNC Relative Power

Defines the power of the secondary synchronization signal (S-SYNC) relative to the reference signal.

Remote command:

`CONFigure[:LTE]:DL:SYNC:SPOwer` on page 214

5.3.2 Configuring the Reference Signal

The reference signal settings contain settings to describe the physical attributes and structure of the reference signal.

The reference signal settings are part of the "Downlink Advanced Signal Characteristics" tab of the "Demodulation Settings" dialog box.

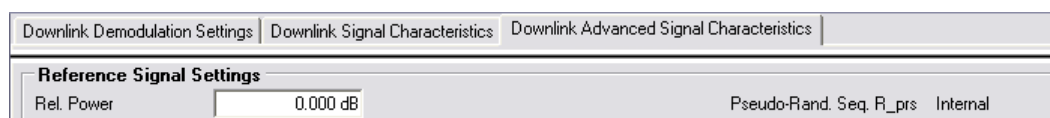

Rel Power (Reference Signal)..... 106

Rel Power (Reference Signal)

Defines the relative power of the reference signal compared to all the other physical signals and physical channels.

Note that this setting gives you an offset to all other relative power settings.

Remote command:

`CONFigure[:LTE]:DL:REFSig:POwer` on page 215

5.3.3 Configuring Positioning Reference Signals

The positioning reference signal settings contain settings to describe the physical attributes and structure of the positioning reference signal.

Positioning reference signals are used to estimate the position of the user equipment.

Resource elements used by positioning reference signals are shown in blue color in the Allocation ID versus Symbol X Carrier measurement.

Note that PDSCH allocations will overwrite the positioning reference signal if they share a common resource block.

The positioning reference signal settings are part of the "Downlink Advanced Signal Characteristics" tab of the "Demodulation Settings" dialog box.

Positioning Reference Signals Settings					
Present	<input checked="" type="checkbox"/>	Configuration Index	<input type="text" value="0"/>	Rel. Power	<input type="text" value="0.000 dB"/>
Bandwidth	<input type="text" value="1.4 MHz (6 RB)"/>	Num. Subframes (N_PRS)	<input type="text" value="1"/>	Frame Number Offset	<input type="text" value="0"/>

Present.....	107
Bandwidth.....	107
Configuration Index.....	107
Num. Subframes (N_PRS).....	107
Relative Power (Positioning Reference Signal).....	108
Frame Number Offset.....	108

Present

Turns the positioning reference signal on and off.

Remote command:

[CONFigure\[:LTE\]:DL:PRSS:STATE](#) on page 215

Bandwidth

Defines the bandwidth and thus the number of resource blocks the positioning reference signal occupies.

Note that the PRS bandwidth has to be smaller than the channel bandwidth.

Remote command:

[CONFigure\[:LTE\]:DL:PRSS:BW](#) on page 215

Configuration Index

Defines the PRS Configuration Index I_{PRS} as defined in 3GPP TS 36.211, table 6.10.4.3-1.

Remote command:

[CONFigure\[:LTE\]:DL:PRSS:CI](#) on page 215

Num. Subframes (N_PRS)

Defines the number of consecutive DL subframes in that PRS are transmitted.

Remote command:

[CONFigure\[:LTE\]:DL:PRSS:NPRS](#) on page 216

Relative Power (Positioning Reference Signal)

Defines the power of a PRS resource element in relation to the power of a common reference signal resource element.

Remote command:

CONFigure[:LTE]:DL:PRSS:POWer on page 216

Frame Number Offset

Defines the system frame number of the current frame that you want to analyze.

Because the positioning reference signal and the CSI reference signal usually have a periodicity of several frames, for some reference signal configurations it is necessary to change the expected system frame number of the frame to be analyzed.

Note that if you define the frame number offset for either reference signal, it is automatically defined for both reference signals.

Remote command:

CONFigure[:LTE]:DL:SFNO on page 216

5.3.4 Configuring Channel State Information Reference Signal

The channel state information reference signal (CSI-RS) settings contain settings to describe the physical attributes and structure of the Channel State Information Reference Signal (CSI-RS).

CSI-RS are used to estimate the channel properties of the signal propagation channel from the base station to the user equipment. This information is quantized and fed back to the base station. The base station makes use of this information for example to adjust the beamforming parameters.

The mapping of antenna port to the physical antenna is fix:

- Port 15: antenna 1
- Port 16: antenna 2
- Port 17: antenna 3
- Port 18: antenna 4

Resource elements used by CSI-RS are shown in yellow color in the Allocation ID versus Symbol X Carrier measurement.

The CSI-RS settings are part of the "Downlink Advanced Signal Characteristics" tab of the "Demodulation Settings" dialog box.

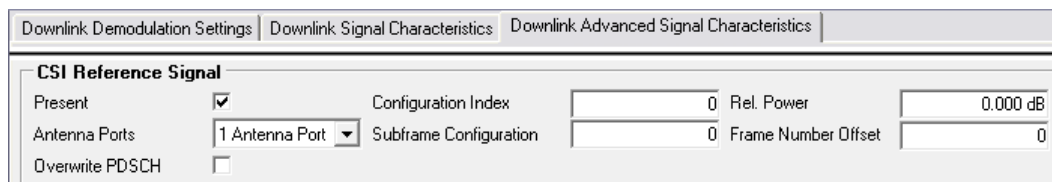

Present..... 109

Antenna Ports..... 109

Configuration Index..... 109

Subframe Configuration..... 109

Relative Power (CSI Reference Signal).....	109
Frame Number Offset.....	109
Overwrite PDSCH.....	110

Present

Turns the CSI reference signal on and off.

Remote command:

[CONFigure\[:LTE\]:DL:CSIRs:STATe](#) on page 218

Antenna Ports

Defines the number of antenna ports that transmit the CSI reference signal.

The CSI reference signals are transmitted on one, two, four or eight antenna ports using

- $p = 15$
- $p = 15$ to 16
- $p = 15$ to 18
- $p = 15$ to 22

Remote command:

[CONFigure\[:LTE\]:DL:CSIRs:NAP](#) on page 217

Configuration Index

Defines the CSI reference signal configuration as defined in 3GPP TS 36.211, table 6.10.5.2-1/2

Remote command:

[CONFigure\[:LTE\]:DL:CSIRs:CI](#) on page 216

Subframe Configuration

Defines the CSI reference signal subframe configuration index ($I_{\text{CSI-RS}}$) as defined in 3GPP TS 36.211, table 6.10.5.3-1.

Remote command:

[CONFigure\[:LTE\]:DL:CSIRs:SCI](#) on page 217

Relative Power (CSI Reference Signal)

Defines the power of a CSI reference signal resource element in relation to the power of a common reference signal resource element.

Remote command:

[CONFigure\[:LTE\]:DL:CSIRs:POWer](#) on page 217

Frame Number Offset

Defines the system frame number of the current frame that you want to analyze.

Because the positioning reference signal and the CSI reference signal usually have a periodicity of several frames, for some reference signal configurations it is necessary to change the expected system frame number of the frame to be analyzed.

Note that if you define the frame number offset for either reference signal, it is automatically defined for both reference signals.

Remote command:

[CONFigure\[:LTE\]:DL:SFNO](#) on page 216

Overwrite PDSCH

Turns overwriting of PDSCH resource elements for UEs that do not consider the CSI reference signal on and off.

If on, the software assumes that the UE is not configured to consider CSI reference signals. Thus, resource elements of the CSI reference signal overwrite the PDSCH resource elements. Note that the bit stream result displays labels these resource element with a "#" sign.

Remote command:

[CONFigure\[:LTE\]:DL:CSIRs:OPDSch](#) on page 217

5.3.5 Defining the PDSCH Resource Block Symbol Offset

PRB Symbol Offset

PRB Symbol Offset specifies the symbol offset of the PDSCH allocations relative to the subframe start. This setting applies to all subframes in a frame.

With this settings, the number of OFDM symbols used for control channels is defined, too. For example, if this parameter is set to 2 and the PDCCH is enabled, the number of OFDM symbols actually used by the PDCCH is 2.

Special control channels like the PCFICH or PHICH require a minimum number of control channel OFDM symbols at the beginning of each subframe. If PRB Symbol Offset is lower than the required value, the control channel data overwrites some resource elements of the PDSCH.

If Auto is selected, the Control Region for PDCCH (PRB Symbol Offset) value is detected from the PCFICH. For correct Demodulation of a 3GPP conform PCFICH signal, the Scrambling of Coded Bits has to be enabled.

Remote command:

[CONFigure\[:LTE\]:DL:PSOffset](#) on page 222

5.3.6 Configuring the Control Channels

The control channel settings contain settings that describe the physical attributes and structure of the control channel.

The control channel settings are part of the "Downlink Advanced Signal Characteristics" tab of the "Demodulation Settings" dialog box.

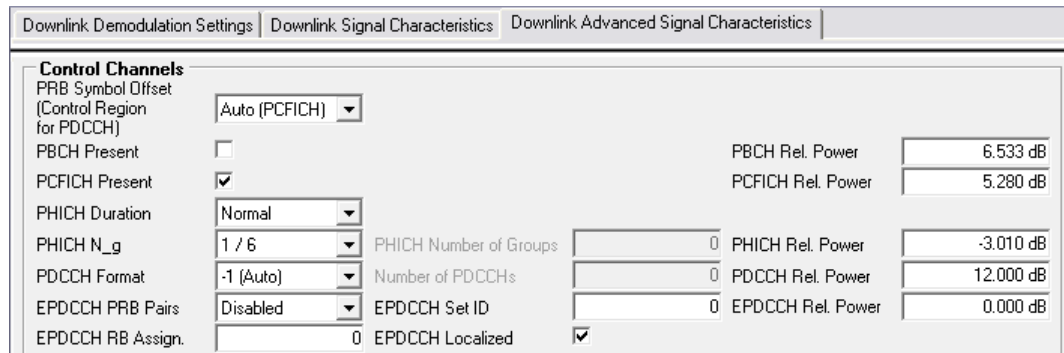

- [Configuring the PBCH](#)..... 111
- [Configuring the PCFICH](#)..... 111
- [Configuring the PHICH](#)..... 112
- [Configuring the PDCCH](#)..... 113
- [Configuring the EPDCCH](#)..... 114

5.3.6.1 Configuring the PBCH

The physical broadcast channel (PBCH) carries system information for the user equipment. You can include or exclude the PBCH in the test setup and define the relative power of this channel.

- [PBCH Present](#)..... 111
- [PBCH Relative Power](#)..... 111

PBCH Present

Includes or excludes the PBCH from the test setup.

Remote command:

`CONFigure[:LTE]:DL:PBCH:STAT` on page 219

PBCH Relative Power

Defines the power of the PBCH relative to the reference signal.

Remote command:

`CONFigure[:LTE]:DL:PBCH:POWer` on page 221

5.3.6.2 Configuring the PCFICH

The physical control format indicator channel (PCFICH) carries information about the format of the PDCCH. You can include or exclude the PCFICH in the test setup and define the relative power of this channel.

- [PCFICH Present](#)..... 112
- [PCFICH Relative Power](#)..... 112

PCFICH Present

Includes or excludes the PCFICH from the test setup.

Remote command:

[CONFigure\[:LTE\]:DL:PCFich:STAT](#) on page 220

PCFICH Relative Power

Defines the power of the PCFICH relative to the reference signal.

Remote command:

[CONFigure\[:LTE\]:DL:PCFich:POWer](#) on page 222

5.3.6.3 Configuring the PHICH

The physical hybrid ARQ indicator channel (PHICH) contains the hybrid ARQ indicator. The hybrid ARQ indicator contains the acknowledgement / negative acknowledgments for uplink blocks.

You can set several specific parameters for the PHICH.

**Turning off the PHICH**

If you set the value of the [PHICH N_g](#) to Custom and at the same time define "0" [PHICH groups](#), the PHICH is excluded from the signal.

PHICH Duration	112
PHICH TDD m_i=1 (E-TM)	112
PHICH N_g	113
PHICH Number of Groups	113
PHICH Rel Power	113

PHICH Duration

Selects the duration of the PHICH. Normal and extended duration are supported.

With a normal duration, all resource element groups of the PHICH are allocated on the first OFDM symbol.

With an extended duration, the resource element groups of the PHICH are distributed over three OFDM symbols for a normal subframe or over two symbols within a special subframe.

If you select Auto, the duration of PHICH is automatically determined and based on the PBCH decoding results.

Note that you have to turn on the PBCH for an automatic determination of the PHICH duration.

Remote command:

[CONFigure\[:LTE\]:DL:PHICH:DURation](#) on page 220

PHICH TDD m_i=1 (E-TM)

Turns the special setting of the PHICH for the enhanced test models on and off.

The special setting is defined in 36.141 V9.0.0, 6.1.2.6: "For frame structure type 2 the factor m_i shall not be set as per TS36.211, Table 6.9-1, but instead shall be set to $m_i=1$ for all transmitted subframes."

The parameter is available if you have selected TDD.

Remote command:

[CONFigure\[:LTE\]:DL:PHICH:MITM](#) on page 221

PHICH N_g

Sets the variable N_g .

N_g in combination with the number of resource blocks defines the number of PHICH groups in a downlink subframe. The standard specifies several values for N_g that you can select from the dropdown menu.

If you need a customized configuration, you can set the number of PHICH groups in a subframe by selecting the "Custom" menu item and set a number of PHICH groups directly with [PHICH Number of Groups](#).

Remote command:

[CONFigure\[:LTE\]:DL:PHICH:NGParameter](#) on page 220

PHICH Number of Groups

Sets the number of PHICH groups contained in a subframe.

To select a number of groups, you have to set the [PHICH \$N_g\$](#) to "Custom".

Remote command:

[CONFigure\[:LTE\]:DL:PHICH:NOGRoups](#) on page 221

PHICH Rel Power

Defines the power of all PHICHs in a PHICH group relative to the reference signal.

The software measures a separate relative power for each PHICH if [Boosting Estimation](#) is on. In that case, the "Rel. Power / dB" result in the Allocation Summary stays empty, because it refers to the common relative power for all PHICHs. The relative powers for each PHICH in the group are displayed in the Channel Decoder Results.

Note that the PHICH power results are quantized to 1 dB steps based on the PHICH relative power, because only a few PHICH symbols are available for boosting estimation.

Example:

The "PHICH Rel Power" is -3.01 dB.

In that case, possible PHICH boostings are -4.01 dB, -3.01 dB, -2.01 dB, etc.

Remote command:

[CONFigure\[:LTE\]:DL:PHICH:POWer](#) on page 222

5.3.6.4 Configuring the PDCCH

The physical downlink control channel (PDCCH) carries the downlink control information (for example the information about the PDSCH resource allocation).

You can define several specific parameters for the PDCCH.

PDCCH Format.....	114
Number of PDCCHs.....	114
PDCCH Rel Power.....	114

PDCCH Format

Defines the format of the PDCCH (physical downlink control channel).

Note that PDCCH format "-1" is not defined in the standard. This format corresponds to the transmission of one PDCCH on all available resource element groups. As a special case for this PDCCH format, the center of the constellation diagram is treated as a valid constellation point.

Remote command:

[CONFigure\[:LTE\]:DL:PDCCh:FORMat](#) on page 220

Number of PDCCHs

Sets the number of physical downlink control channels.

This parameter is available if the PDCCH format is -1.

Remote command:

[CONFigure\[:LTE\]:DL:PDCCh:NOPD](#) on page 221

PDCCH Rel Power

Defines the power of the PDCCH relative to the reference signal.

Remote command:

[CONFigure\[:LTE\]:DL:PDCCh:POWer](#) on page 222

5.3.6.5 Configuring the EPDCCH

The enhanced physical downlink control channel (EPDCCH) carries the downlink control information. Compared to the PDCCH, the EPDCCH uses resource blocks normally reserved for the PDSCH.



Shared resource blocks of PDSCH and EPDCCH

PDSCH allocations overwrite the EPDCCH if they occupy the same resource blocks.

The EPDCCH is always transmitted in an EPDCCH-PRB set. For each cell and user, you can define one or two EPDCCH-PRB sets. A EPDCCH-PRB set is made up out of two or more resource blocks that are combined logically.

Note that you have to measure one EPDCCH-PRB set at a time. If you have to measure a signal with more than one EPDCCH-PRB set, you have to configure each set separately and refresh the I/Q data for each set.

You can define several parameters for the EPDCCH.

EPDCCH PRB Pairs.....	115
EPDCCH Set ID.....	115
EPDCCH Rel Power.....	115
EPDCCH RB Assignment.....	115
EPDCCH Localized.....	115

EPDCCH PRB Pairs

Selects the number of resource blocks used in an EPDCCH-PRB set.

If you select the "Disabled" item, the EPDCCH is turned off.

For more information see 3GPP TS 36.213 (*numberPRBPairs-r11*).

Remote command:

[CONFigure\[:LTE\]:DL:EPDCch:NPRB](#) on page 219

EPDCCH Set ID

Defines the EPDCCH set ID.

The set ID controls the generation of reference symbols for the EPDCCH. For more information see TS36.211, 6.10.3A.1.

Remote command:

[CONFigure\[:LTE\]:DL:EPDCch:SID](#) on page 219

EPDCCH Rel Power

Defines the power of the EPDCCH relative to the reference signal.

Remote command:

[CONFigure\[:LTE\]:DL:EPDCch:POWer](#) on page 219

EPDCCH RB Assignment

Defines the location of the resource blocks that the EPDCCH is transmitted in.

For more information see 3GPP TS 36.213 (*resourceBlockAssignment-r11*).

Remote command:

[CONFigure\[:LTE\]:DL:EPDCch:RBASsign](#) on page 219

EPDCCH Localized

Turns localized transmission of the EPDCCH on and off.

Localized transmission is useful for known channel conditions. In that case, the scheduling and MIMO precoding can be optimized.

If the channel conditions are unknown, distributed transmission is used. Distributed transmission utilizes the frequency diversity in that the information is distributed over the selected frequency range.

Remote command:

[CONFigure\[:LTE\]:DL:EPDCch:LOCalized](#) on page 218

5.3.7 Configuring the Shared Channel

The shared channel settings contain settings that describe the characteristics of the shared channels.

The shared channel settings are part of the "Downlink Advanced Signal Characteristics" tab of the "Demodulation Settings" dialog box.

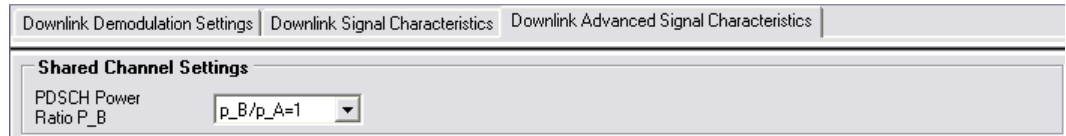

PDSCH Power Ratio

Selects the PDSCH P_B parameter that defines the cell-specific ratio of rho_B to rho_A according to 3GPP TS 36.213, table 5.2-1.

The table below shows the resulting values as a function of the number of antennas.

PDSCH P_B	1 Tx antenna	2 and 4 Tx antennas
0	0.000 dB	0.969 dB
1	-0.969 dB	0.000 dB
2	-2.218 dB	-1.249 dB
3	-3.979 dB	-3.010 dB

If you select "p_B/p_A=1", the ratio is always 1, regardless of the number of antennas.

Remote command:

`CONFigure[:LTE]:DL:PDSch:PB` on page 223

5.4 Defining MBSFN Characteristics

The MBSFN settings contain settings to configure Multimedia Broadcast Single Frequency Networks (MBSFNs).

You can find the MBSFN characteristics in the "Demod Settings" dialog box.

- [Configuring MBSFNs](#)..... 116
- [Configuring MBSFN Subframes](#)..... 117

5.4.1 Configuring MBSFNs

The general MBSFN settings contain settings that apply to all subframes that contain MBSFN information.

The MBSFN settings are part of the "MBSFN Settings" tab of the "Demodulation Settings" dialog box.

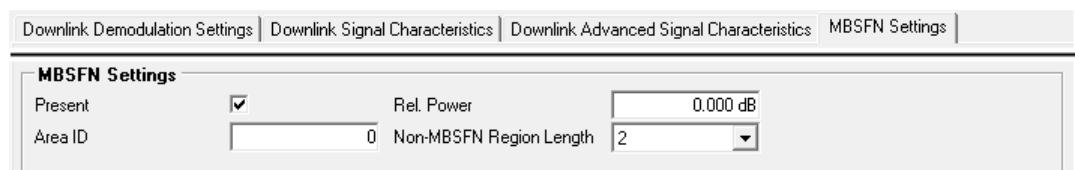

Present.....	117
Area ID.....	117
MBSFN Relative Power.....	117
Non-MBSFN Region Length.....	117

Present

Includes or excludes an MBSFN from the test setup.

Remote command:

`CONFigure[:LTE]:DL:MBSFn:STATe` on page 224

Area ID

Defines the ID for an MBSFN area.

Radio cells that shall transmit the same content to multiple users will form a so called MBSFN area. Multiple cells can belong to such an area, and every cell can be part of up to eight MBSFN areas. There could be up to 256 different MBSFN areas defined, each one with an own identity.

The area ID (N_{ID}^{MBSFN}) is defined in 3GPP 36.211.

Remote command:

`CONFigure[:LTE]:DL:MBSFn:AI:ID` on page 224

MBSFN Relative Power

Defines the power of the MBSFN transmission relative to the reference signal.

Remote command:

`CONFigure[:LTE]:DL:MBSFn:POWer` on page 224

Non-MBSFN Region Length

Selects the length of the MBSFN control data region at the start of the MBSFN sub-frame.

If you select a region length of '1', the first symbol in an MBSFN subframe carries data of the control channel. All other symbols of an MBSFN region may be used by the PMCH.

If you select a region length of '2', the first two symbols in an MBSFN subframe carry data of the control channel.

Remote command:

`CONFigure[:LTE]:DL:MBSFn:AI:NMRL` on page 224

5.4.2 Configuring MBSFN Subframes

If you are testing systems that support MBSFN, 3GPP allows you to reserve one or more subframes for multimedia broadcasting.

The MBSFN subframe configuration is part of the "MBSFN Settings" tab of the "Demodulation Settings" dialog box.

MBSFN Subframe Configuration				
	MBSFN Subframe	Active	PMCH Present	Modulation
▶	1	<input checked="" type="checkbox"/>	<input checked="" type="checkbox"/>	QPSK ▼
	2	<input type="checkbox"/>	<input type="checkbox"/>	QPSK ▼
	3	<input type="checkbox"/>	<input type="checkbox"/>	QPSK ▼
	6	<input type="checkbox"/>	<input type="checkbox"/>	QPSK ▼
	7	<input type="checkbox"/>	<input type="checkbox"/>	QPSK ▼
	8	<input type="checkbox"/>	<input type="checkbox"/>	QPSK ▼

MBSFN Subframe..... 118
 Active..... 118
 PMCH Present..... 118
 Modulation..... 118

MBSFN Subframe

Shows the subframe number that may contain MBSFN data.

Note that 3GPP only allows to turn selected subframes into MBSFN subframes. Depending on the configuration (for example the TDD configuration), different subframe numbers are available for MBSFN transmissions.

Active

Turns a subframe into a MBSFN subframe.

If active, the corresponding subframe may contains MBSFN data.

Remote command:

`CONFigure[:LTE]:DL:MBSFn:SUBFrame<subframe>:STATe` on page 225

PMCH Present

Turns the Physical Multicast Channel (PMCH) on and off.

If you turn on the PMCH, the resource elements of the MBSFN subframe are used by the PMCH.

If you turn off the PMCH, the resource elements of the MBSFN subframe may be used by the PDSCH.

Remote command:

`CONFigure[:LTE]:DL:MBSFn:SUBFrame<subframe>:PMCH:STATe` on page 225

Modulation

Selects the modulation scheme for the MBSFN subframe.

Remote command:

`CONFigure[:LTE]:DL:MBSFn:SUBFrame<subframe>:PMCH:MODulation` on page 225

6 Analyzing Measurement Results

The measurement software provides several tools to get more detailed information on the measurement results. The corresponding tools are part of the context menu.

- ▶ To access the context menu, click anywhere in the diagram grid with the right mouse button.

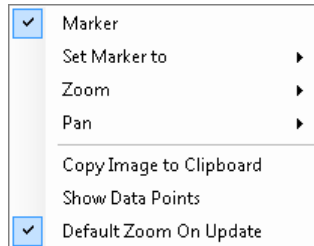

Fig. 6-1: Context menu

Using the marker

You can use a marker to get the coordinates of a single point in the diagram area.

- ▶ Open the context menu and select the "Marker" menu item.
When the marker is active, the software puts a check mark () in front of the "Marker" menu item.

When you turn it on, the software positions the marker on the trace maximum. After that you can move it around freely to any point of the trace.

In result displays that contain more than one trace (for example EVM vs Carrier), you can select the trace the marker is positioned on (Peak, Minimum or Average trace) with the "Set Marker To" menu item. Note that "Set Marker To" is only available if a marker is already active.



Marker positioning

If you try to put the marker on a coordinate not occupied by the trace, the software puts the marker to the nearest trace maximum (if you place it above the trace) or the nearest trace minimum (if you place it below the trace).

The marker coordinates are displayed in the upper left area of the diagram. The first number shows the vertical position, the second number the horizontal position of the marker including the units.

Mkr: -8.920 dBm @ 38.141 ms



If you want to reposition the marker on the trace maximum after moving it around, you have to first deactivate the marker and then reactivate it.

To deactivate the marker, open the context menu and reselect the "Marker" menu item.



Note that the marker is not available for all measurements and result displays.

Displaying data points

In result displays that contain a line trace only (for example the Power Spectrum), you can display the data points the trace is based on with the "Show Data Points" menu item. The data points are displayed in addition to the line trace.

Some result displays already contain the data points by default (for example EVM vs Symbol). Note that information might get lost if you turn the data points off in these result displays.

Zooming into the diagram area

If you'd like to see parts of the diagram area in more detail, you can use the zoom.

- ▶ Open the context menu and select the "Zoom" menu item.
The software opens a submenu with several zooming options.

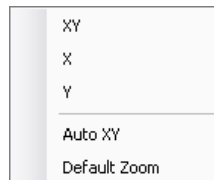

Fig. 6-2: Zooming options

- Zooming vertically and horizontally (XY)
Click on any point in the diagram area and draw a rectangle with the mouse. The rectangle defines the part of the diagram area you are zooming into.
- Zooming horizontally (X)
Click on any point in the diagram area and define the horizontal section of the diagram area you want to zoom into.
- Zooming vertically (Y)
Click on any point in the diagram area and define the vertical section of the diagram area you want to zoom into.
- Zooming automatically (Auto XY)
Automatically scales the diagram area so that the complete trace data is visible. Double-clicking on the diagram has the same effect.
- Restoring the default zoom
The "Default Zoom" entry restores the default zoom.

The software also provides functionality to restore the default zoom each time when the results are refreshed.

- ▶ Open the context menu and select the "Default Zoom on Update" menu item.

Panning the trace

If you'd like to see parts of the measurement results that are outside the diagram area, you can move the contents of the diagram area. To move the contents of the diagram area, click anywhere in the diagram area and drag the contents of the diagram area until the parts you'd like to see are visible.



If there are parts of the trace data that are outside the visible display area, the software shows arrows to the right of the diagram area.

The arrows point in the direction where the invisible trace data is. If parts of the trace data is outside the visible area, the arrows are yellow. If all data in a particular direction is outside the visible area, the arrows turn red.



To make sure that the whole trace is always visible, you can use the automatic zoom ("Auto XY") available in the "Zoom" menu.

- ▶ Open the context menu and select the "Pan" menu item.
The software opens a submenu with several panning options.

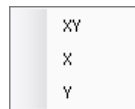

Fig. 6-3: Panning options

- Panning vertically and horizontally (XY)
Panning is possible in all directions.
- Panning horizontally (X)
Panning is possible to the left and right.
- Panning vertically (Y)
Panning is possible upwards and downwards.

Copying an image to the clipboard

If you want to document measurement results, you can move a copy of them to the clipboard of the operating system.

- ▶ Open the context menu and select the "Copy to Clipboard" menu item.

7 Data Management

For easy handling of special measurement configurations, the software allows you to import or export various kinds of data.

7.1 Importing and Exporting I/Q Data

Instead of capturing data directly through hardware components, you can also analyze data that has been recorded previously and saved in a file. On the same lines, it is also possible to save the data that has been captured with an analyzer for further analysis at a later time or for documentation.

You can store and load I/Q data in binary or ASCII format. For a correct display of the power, the I/Q data has to be scaled linearly in Volt (e.g. for the Capture Buffer result display).



Loading I/Q data

Load the contents of an I/Q data file into the software fast and easy by dragging and dropping the file somewhere into the user interface.

The software updates the I/Q data to be measured automatically.

All functionality to import and export data is in the "File" menu (or file manager) that you can access via the FILE key.

ASCII format (.dat format)

In case of the ASCII (.dat) format, the data is expected as I and Q values in alternating rows.

<I value 1>

<Q value 1>

<I value 2>

<Q value 2>

(...)

To be able to analyze previously recorded data, you have to set the [input source](#) to "File". When you start a measurement, the software will ask you to select a file that contains the data.

To save data, enter the file manager and save the data with "Save IQ Data".

Binary format (.iqw format)

In case of the binary .iqw format, the data is expected in 32-bit floating point format. This format is also known as Little Endian, LSB Order or Intel format.

Example:

The hexadecimal value 0x1D86E7BB would be decoded to -7.0655481E-3.

For single antenna measurements, the order of the I/Q data is either IQIQIQ... or II...IQQ...Q.

For MIMO measurements, you also have to consider the antenna in the order of the data, with alternating I and Q data for every antenna.

[I/Q][antenna index]([symbol index])

Example:

For a two antenna system, the string of data would like:

I0(0),Q0(0),I1(0),Q1(0),I0(1),Q0(1),I1(1),Q1(1),I0(2),Q0(2),...

Binary format (.iq.tar format)

In case of the .iq.tar format, the I/Q data is stored in a compressed format with the file extension .iq.tar.

An .iq.tar file contains I/Q data in binary format together with meta information that describes the nature and the source of data, e.g. the sample rate. The objective of the .iq.tar file format is to separate I/Q data from the meta information while still having both inside one file. In addition, the file format allows you to preview the I/Q data in a web browser, and allows you to include customized data.

An .iq.tar file must contain the following files.

- I/Q parameter XML file
Contains meta information about the I/Q data (e.g. sample rate). The filename can be defined freely, but there must be only one single I/Q parameter XML file inside an .iq.tar file.
- I/Q data binary file
Contains the binary I/Q data of all channels. There must be only one single I/Q data binary file inside an .iq.tar file.

Optionally, an .iq.tar file can contain the following file.

- I/Q preview XSLT file
Contains a stylesheet to display the I/Q parameter XML file and a preview of the I/Q data in a web browser.

7.2 Managing Frame Data

For fast access to the frame description (or structure of a signal), you can save it and again use it at a later time. To manage frame descriptions, enter the file manager and select "Save Demod Setup" to save the current setup or "Load Demod Setup" to restore a previously created setup.

The frame description contains the complete modulation structure of the signal.

The frame structure is defined in the xml file format. The file contains all parameters that are part of the demodulation settings. If you want to define more than one allocation, you can do so by adding additional PRB entries (<PRB> element).

Note the following restrictions for the frame description.

- You have to define at least one PRB.
- You can allocate a maximum of four frames.

The example below shows a typical frame description.

```
<FrameDefinition LinkDirection="downlink" TDDULDLAllocationConfiguration="0"
TDDSpecialSubframeConfiguration="0" ResourceBlocks="50" CP="auto" PSYNBoostingdB="0"
SSYNBoostingdB="0" PSSYNCTxAntenna="All" ReferenceSignalBoostingdB="0"
PBCHIsPresent="true" PBCHBoostingdB="0" PCFICHIsPresent="true" PCFICHBoostingdB="0"
PHICH_Ng="1" PHICHNumGroups="0" PHICHDuration="Normal" PHICHBoostingdB="-3.01"
PHICHTDDSetMiAccToETMs="false" NumberOfPDCCHs="0" PDCCHFormat="-1"
PDCCHBoostingdB="0" PSSYNCRetpetitionPeriod="10" DataSymbolOffsetSubFrame="-1"
MIMOConfiguration="1 Tx Antenna" MIMOAntennaSelection="Antenna 1"
PhysLayCellIDGrp="Auto" PhysLayID="Auto" RefSignal3GPPVersion="3"
N_c_fastforward="1600">
  <Frame>
    <Subframe>
      <PRBs>
        <PRB Start="0" Length="6" Boosting="0" Modulation="QPSK" Precoding="None"
          Layers="1" Codebook="0" CDD="0" N_RNTI="0"></PRB>
      </PRBs>
    </Subframe>
  </Frame>
  <stControl PhaseTracking="1" TimingTracking="0" ChannelEstimation="1"
    EVMCalculationMethod="1" CompensateCrosstalk="0" EnableScrambling="1"
    AutoDemodulation="1" AutoBoostingEstimation="1" SubframeConfDetect="2"
    RefDataSource="1" MulticarrierFilter="0"></stControl>
</FrameDefinition>
```

7.3 Importing and Exporting Limits

In addition to the limits defined by the standard, you can create and use customized limits. After you have created the file, you have to name it Default.eutra_limits and copy it into the same folder as the software binary ("%Program folder%\Rohde-Schwarz\EUTRA LTE" by default). The limits are automatically loaded when you start the software.

The limits you can customize work for the Result Summary.

Limits are defined in the xml file format. Any xml elements you do not want to define can be left out, either by making no entry or by deleting the corresponding element.

```
<Limits>
  <DL>
    <EVM>
```

```

<PDSCHQPSK Mean="0.175"></PDSCHQPSK><!--Unit: linear (1 = 0 dB, 0.1 = -20 dB)-->
<PDSCH16QAM Mean="0.125"></PDSCH16QAM><!--Unit: linear (1 = 0 dB, 0.1 = -20 dB)-->
<PDSCH64QAM Mean="0.08"></PDSCH64QAM><!--Unit: linear (1 = 0 dB, 0.1 = -20 dB)-->
<PhysicalChannel></PhysicalChannel><!--Unit: linear (1 = 0 dB, 0.1 = -20 dB)-->
<PhysicalSignal></PhysicalSignal><!--Unit: linear (1 = 0 dB, 0.1 = -20 dB)-->
<All></All><!--Unit: linear (1 = 0 dB, 0.1 = -20 dB)-->
</EVM>
<FrequencyError></FrequencyError><!--Unit: [Hz]-->
<SamplingClockError></SamplingClockError><!--Unit: [ppm]-->
<TimeAlignmentError></TimeAlignmentError><!--Unit: [ns]-->
<IQOffset></IQOffset><!--Unit: linear (1 = 0 dB, 0.1 = -20 dB)-->
<IQGainImbalance></IQGainImbalance><!--Unit: linear (1 = 0 dB, 0.1 = -20 dB)-->
<IQQuadraturError></IQQuadraturError><!--Unit: [°]-->
<OSTP></OSTP><!--Unit: [W]-->
<PowerTotal></PowerTotal><!--Unit: [W]-->
<CrestFactor></CrestFactor><!--Unit: linear (1 = 0 dB, 10 = 10 dB)-->
<OffPowSpectralDensity Limit="-85"></OffPowSpectralDensity><!--Unit: [dBm/MHz]-->
</DL>
</Limits>

```

8 Measurement Basics

This chapter provides background information on the measurements and result displays available with the LTE Analysis Software.

- [Symbols and Variables](#)..... 126
- [Overview](#)..... 127
- [The LTE Downlink Analysis Measurement Application](#)..... 127
- [MIMO Measurement Guide](#)..... 130
- [Calibrating Beamforming Measurements](#)..... 136
- [Performing Time Alignment Measurements](#)..... 138
- [Performing Transmit On/Off Power Measurements](#)..... 140

8.1 Symbols and Variables

The following chapters use various symbols and variables in the equations that the measurements are based on. The table below explains these symbols for a better understanding of the measurement principles.

$a_{i,k}, \hat{a}_{i,k}$	data symbol (actual, decided)
$b_{i,k}$	boosting factor
$\Delta f, \Delta \hat{f}_{\text{coarse}}$	carrier frequency offset between transmitter and receiver (actual, coarse estimate)
Δf_{res}	residual carrier frequency offset
ζ	relative sampling frequency offset
$H_{i,k}, \hat{H}_{i,k}$	channel transfer function (actual, estimate)
i	time index
$\hat{t}_{\text{coarse}}, \hat{t}_{\text{fine}}$	timing estimate (coarse, fine)
k	subcarrier index
l	OFDM symbol index
N_{FFT}	length of FFT
N_g	number of samples in cyclic prefix (guard interval)
N_s	number of Nyquist samples
N_{RE}	number of resource elements
n	subchannel index, subframe index
$n_{i,k}$	noise sample
Φ_l	common phase error
$r(i)$	received sample in the time domain

$r_{l,k}$, $r'_{l,k}$, $r''_{l,k}$	received sample (uncompensated, partially compensated, equalized) in the frequency domain
T	useful symbol time
T_g	guard time
T_s	symbol time

8.2 Overview

The digital signal processing (DSP) involves several stages until the software can present results like the EVM.

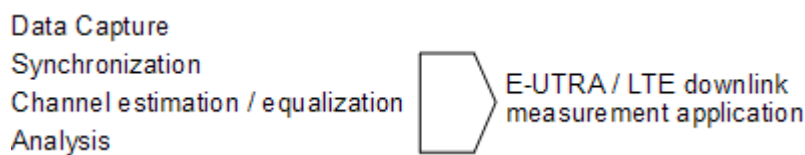

The contents of this chapter are structured like the DSP.

8.3 The LTE Downlink Analysis Measurement Application

The block diagram in [figure 8-1](#) shows the EUTRA/LTE downlink measurement application from the capture buffer containing the I/Q data to the actual analysis block. The outcome of the fully compensated reference path (green) are the estimates $\hat{a}_{i,k}$ of the transmitted data symbols $a_{i,k}$. Depending on the user-defined compensation, the received samples $r''_{l,k}$ of the measurement path (yellow) still contain the transmitted signal impairments of interest. The analysis block reveals these impairments by comparing the reference and the measurement path. Prior to the analysis, diverse synchronization and channel estimation tasks have to be accomplished.

8.3.1 Synchronization

The first of the synchronization tasks is to estimate the OFDM symbol timing, which coarsely estimates both timing and carrier frequency offset. The frame synchronization block determines the position of the P-/S-Sync symbols in time and frequency by using the coarse fractional frequency offset compensated capture buffer and the timing estimate \hat{t}_{coarse} to position the window of the FFT. If no P-/S-Sync is available in the signal, the reference signal is used for synchronization. The fine timing block prior to the FFT allows a timing improvement and makes sure that the EVM window is centered on the measured cyclic prefix of the considered OFDM symbol. For the 3GPP EVM calculation according to 3GPP TS 36.211 (v8.9.0), the block “window” produces three signals taken at the timing offsets $\Delta\tilde{t}_c$, $\Delta\tilde{t}_i$ and $\Delta\tilde{t}_h$. For the reference path, only the signal taken at the timing offset $\Delta\tilde{t}_c$ is used.

The LTE Downlink Analysis Measurement Application

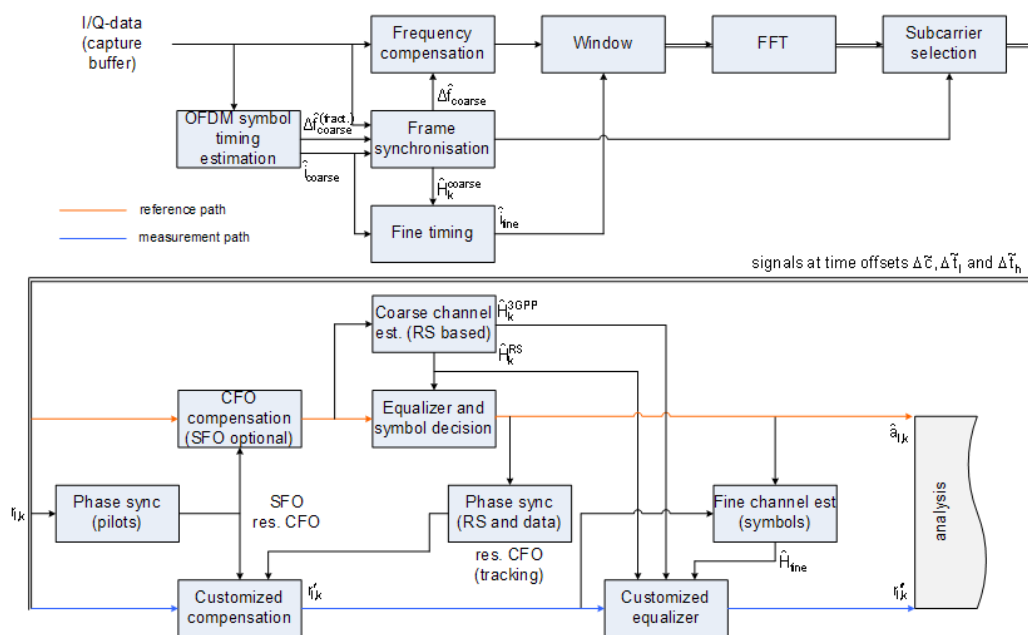

Fig. 8-1: Block diagram for the LTE DL measurement application

After the time to frequency transformation by an FFT of length N_{FFT} , the phase synchronization block is used to estimate the following:

- the relative sampling frequency offset ζ (SFO)
- the residual carrier frequency offset Δf_{res} (CFO)
- the common phase error Φ_1 (CPE)

According to 3GPP TS 25.913 and 3GPP TR 25.892, the uncompensated samples can be expressed as

$$R_{l,k} = A_{l,k} \cdot H_{l,k} \cdot \underbrace{e^{j\Phi_1}}_{CPE} \cdot \underbrace{e^{j2\pi \cdot N_s / N_{FFT} \cdot \zeta \cdot k \cdot l}}_{SFO} \cdot \underbrace{e^{j2\pi \cdot N_s / N_{FFT} \cdot \Delta f_{res} \cdot T \cdot l}}_{res. CFO} + N_{l,k} \tag{8 - 1}$$

where

- the data symbol is $a_{l,k}$, on subcarrier k at OFDM symbol l
- the channel transfer function is $h_{l,k}$
- the number of Nyquist samples is N_s within the symbol time T_s
- the useful symbol time $T = T_s - T_g$
- the independent and Gaussian distributed noise sample is $n_{l,k}$

Within one OFDM symbol, both the CPE and the residual CFO cause the same phase rotation for each subcarrier, while the rotation due to the SFO depends linearly on the subcarrier index. A linear phase increase in symbol direction can be observed for the residual CFO as well as for the SFO.

The results of the tracking estimation block are used to compensate the samples $r_{l,k}$

Whereas a full compensation is performed in the reference path, the signal impairments that are of interest to the user are left uncompensated in the measurement path.

After having decided the data symbols in the reference path, an additional phase tracking can be utilized to refine the CPE estimation.

8.3.2 Channel Estimation and Equalization

As shown in [figure 8-1](#), there is one coarse and one fine channel estimation block. The reference signal-based coarse estimation is tapped behind the CFO compensation block (SFO compensation can optionally be enabled) of the reference path. The coarse estimation block uses the reference signal symbols to determine estimates of the channel transfer function by interpolation in both time and frequency direction. A special channel estimation (H_k^{3GPP}) as defined in 3GPP TS 36.211 is additionally generated. The coarse estimation results are used to equalize the samples of the reference path prior to symbol decision. Based on the decided data symbols, a fine channel estimation is optimally performed and then used to equalize the partially compensated samples of the measurement path.

8.3.3 Analysis

The analysis block of the EUTRA/LTE downlink measurement application allows to compute a variety of measurement variables.

EVM

The error vector magnitude (EVM) measurement results 'EVM PDSCH QPSK/16-QAM/64-QAM' are calculated according to the specification in 3GPP TS 36.211.

All other EVM measurement results are calculated according to

$$EVM_{l,k} = \frac{|r_{l,k}'' - \hat{a}_{l,k}|}{b_{l,k} \sqrt{E \left\{ \left| \frac{a_{l,k}}{b_{l,k}} \right|^2 \right\}}} \quad (8 - 2)$$

on subcarrier k at OFDM symbol l, where $b_{l,k}$ is the boosting factor. Since the average power of all possible constellations is 1 when no boosting is applied, the equation can be rewritten as

$$EVM_{n,l} = \frac{|r_{l,k}'' - \hat{a}_{l,k}|}{b_{l,k}} \quad (8 - 3)$$

The average EVM of all data subcarriers is then

$$EVM_{data} = \sqrt{\frac{1}{N_{REdata}} \sum_l \sum_{k_{data}} EVM_{l,k_{data}}^2}$$
(8 - 4)

The number of resource elements taken into account is denoted by $N_{RE\ data}$.

I/Q imbalance

The I/Q imbalance can be written as

$$r(t) = I \Re\{s(t)\} + jQ \Im\{s(t)\}$$
(8 - 5)

where $s(t)$ is the transmit signal, $r(t)$ is the received signal, and I and Q are the weighting factors. We define that $I:=1$ and $Q:=1+\Delta Q$.

The I/Q imbalance estimation makes it possible to evaluate the

$$\text{modulator gain balance} = |1 + \Delta Q|$$
(8 - 6)

and the

$$\text{quadrature mismatch} = \arg\{1 + \Delta Q\}$$
(8 - 7)

based on the complex-valued estimate $\Delta \hat{Q}$.

Other measurement variables

Without going into detail, the EUTRA/LTE downlink measurement application additionally provides the following results.

- Total power
- Constellation diagram
- Group delay
- I/Q offset
- Crest factor
- Spectral flatness

8.4 MIMO Measurement Guide

Performing MIMO measurements requires additional equipment that allows you to capture multiple data streams.

- Several signal analyzers, the number depending on the number of data streams you have to capture.
Alternatively, you can use an oscilloscope with multiple channels, the number of channels also depending on the number of data streams you have to capture.

- At least one analyzer equipped with option R&S FS(x)-K102(PC) that unlocks MIMO functionality.

True MIMO measurements are useful to verify MIMO precoding implementations for setups where it is not possible to decode the transmit data using only one antenna (e.g. applying spatial multiplexing MIMO precoding with more than 1 layer) and to measure the hardware performance of the MIMO transmitter hardware in a true MIMO measurement setup.

8.4.1 MIMO Measurements with Signal Analyzers

MIMO measurements require multiple signal analyzers. The number depends on the number of data streams you have to capture.

For valid measurement results, the frequencies of the analyzers in the test setup have to be synchronized. It is also necessary to configure the trigger system properly to capture the data simultaneously.

Synchronizing the frequency

The frequency of the analyzers in the test setup have to be synchronized. Thus, one of the analyzers (master) controls the other analyzers (slaves) in the test setup. The master analyzer has to be equipped with the LTE MIMO application and provides the reference oscillator source for the slave analyzers.

- ▶ Connect the REF OUT of the master to the REF IN connector of the slaves. Make sure to configure the slaves to use an external reference (→ General Setup menu).

If you are using a measurement setup with several R&S signal generators (for example R&S SMW), the situation is similar. One of the generators controls the other via the external reference.

- ▶ Connect the REF OUT of the master to the REF IN of the slaves. Make sure to configure the slaves to use an external reference (→ Reference Oscillator settings).

Triggering MIMO measurements

For valid MIMO measurements, it is crucial to capture all data streams simultaneously. To do so, you need a trigger signal provided by the DUT or the signal generator. The trigger signal has to be connected to all analyzers. If you have several signal generators in the setup, the master generator has to trigger the slave as well.

The [8-2](#) shows a MIMO setup with two (or optional four) analyzers and one (or optional two) signal generators with two channels.

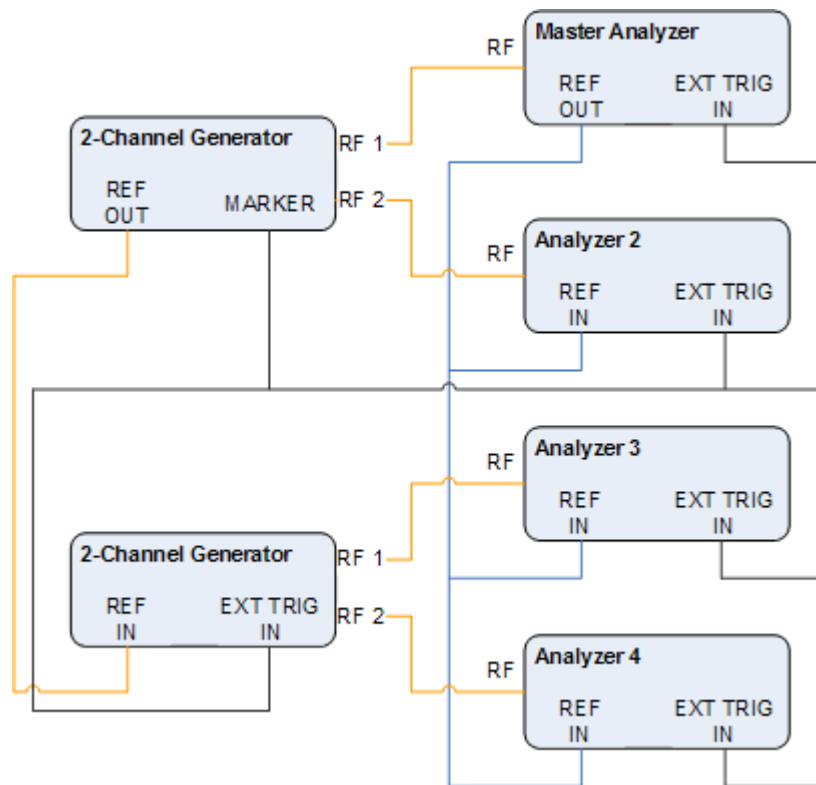

Fig. 8-2: MIMO Hardware Setup

You can use several trigger configurations, with or without additional hardware.

Measurements with a delayed trigger signal

Simultaneous capture of the I/Q data requires the trigger inputs of all instruments in the setup to be armed.

Arming a trigger does not happen immediately when you start a measurement, but is delayed slightly for a number of reasons, for example:

- Connecting several instruments with a LAN or GPIB connection usually causes a certain network delay.
- Tasks like the auto leveling function require some time to finish.

Because of these factors, you have to make sure that the trigger event does not occur during this time frame. You can do so, for example, by configuring an appropriate delay time on the DUT.

The exact delay depends on the GPIB or network condition and the input settings.

You can estimate the delay by performing a single measurement on one analyzer. Measure the time it takes until the "DSP" indicator starts flashing.



Note that this estimation also includes the time it takes to transfer the I/Q samples from the analyzer to the software.

A typical delay to arm the trigger is 2 seconds per instrument.

The minimum delay of the trigger signal must now be greater than the measured time multiplied with the number of measured antennas (the number of analyzers), because the spectrum analyzers are initialized sequentially.

The usage of an LTE frame trigger is not possible for this measurement setup.

Measurements with a frame trigger signal

You can use a frame trigger if all transmitted LTE frames use the same frame configuration and contain the same data. In this case, the analyzers in the test setup capture data from different LTE frames but with the same content.

This method to analyze data, however, raises one issue. The phase variations of the reference oscillators of the different signals that are transmitted are not the same, because the data is not captured simultaneously.

The result is a phase error which degrades the EVM (see the figures below).

An application for this measurement method is, for example, the test of the MIMO precoding implementation. Because of the bad EVM values, it is not recommended to use this test setup to measure hardware performance.

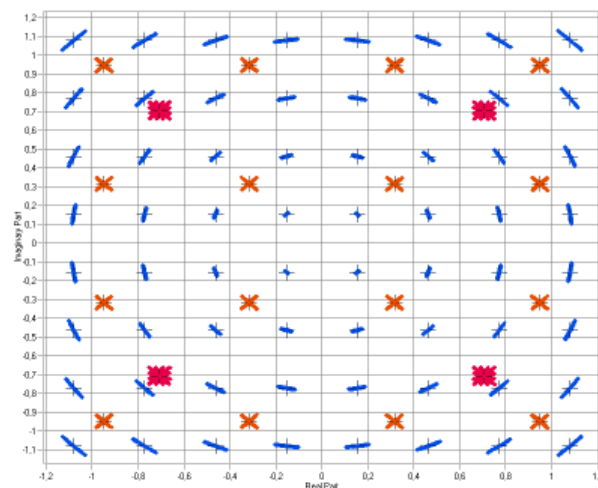

Fig. 8-3: Constellation diagram

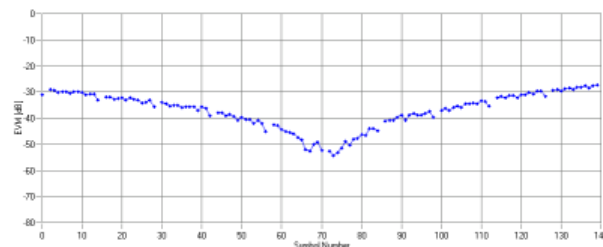

Fig. 8-4: EVM vs OFDM symbol number

Measurements with the R&S FS-Z11 trigger unit

The trigger unit R&S FS-Z11 is a device that makes sure that the measurement starts on all analyzers (master and slaves) at the same time.

Connecting the trigger unit

- ▶ Connect the NOISE SOURCE output of the master analyzer to the NOISE SOURCE CONTROL input of the trigger unit.
- ▶ Connect the EXT TRIG inputs of all analyzers (master **and** slaves) to the TRIG OUT 1 to 4 (or 1 and 2 in case of measurements on two antennas) of the trigger unit. The order is irrelevant, that means it would be no problem if you connect the master analyzer to the TRIG OUT 2 of the trigger unit.

With this setup, all analyzers (including the master analyzer) are triggered by the trigger unit.

The trigger unit also has a TRIG INPUT connector that you can connect an external trigger to. If you are using an external trigger, the external trigger supplies the trigger event. If not, the analyzer noise source control supplies the trigger event. Note that if you do not use an external trigger, the TRIG INPUT must remain open.

To use the R&S FS-Z11 as the trigger source, you have to select it as the trigger source in the "General Settings" dialog box of the LTE measurement application. For more information see "[Configuring the Trigger](#)" on page 81.

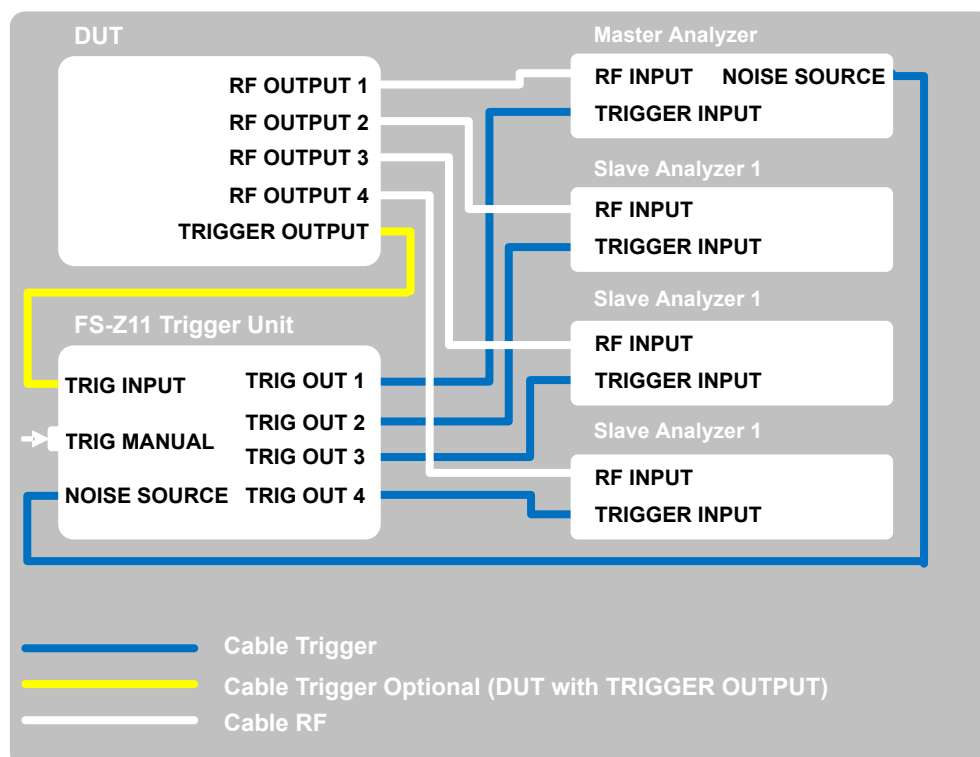

8.4.2 MIMO Measurements with Oscilloscopes

This part presents an approach to measure a MIMO signal transmitted on two or four antennas using the R&S®RTO1044 digital oscilloscope, 4 GHz, 4 channels and the R&S®FS-K102/103PC LTE MIMO downlink/uplink PC software. This has multiple advantages:

- Only one measurement instrument is required. This not only reduces the number of test instruments but also simplifies the test setup and cabling (no reference oscillator and trigger cabling, no additional hardware for synchronization required like the R&S®FS-Z11).
- The measurement time is reduced.

For measuring LTE signals with the RTO it has to be equipped with the options R&S®RTO-B4 and R&S®RTO-K11.

The hardware setup is illustrated in [figure 8-5](#). All transmit antennas (TX) of the device under test (DUT) or an SMU are connected to the RF input of the RTO. Either two or optionally four antennas are attached. The LTE-Software runs on a PC and is connected to the RTO via a local area network (LAN).

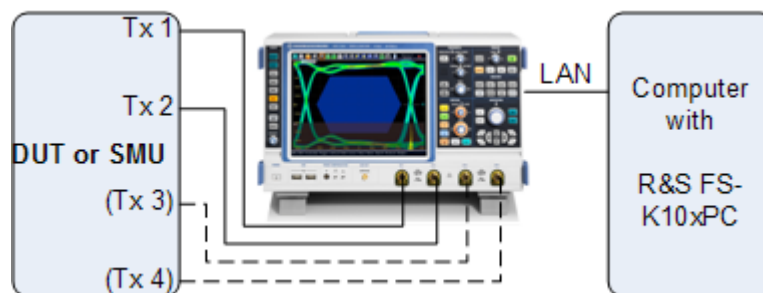

Fig. 8-5: Test setup for LTE MIMO measurements with an oscilloscope

To successfully connect the software to the oscilloscope, enter the correct network address in the "Analyzer Configuration" table and define the hardware properties (for example the number of input channels).

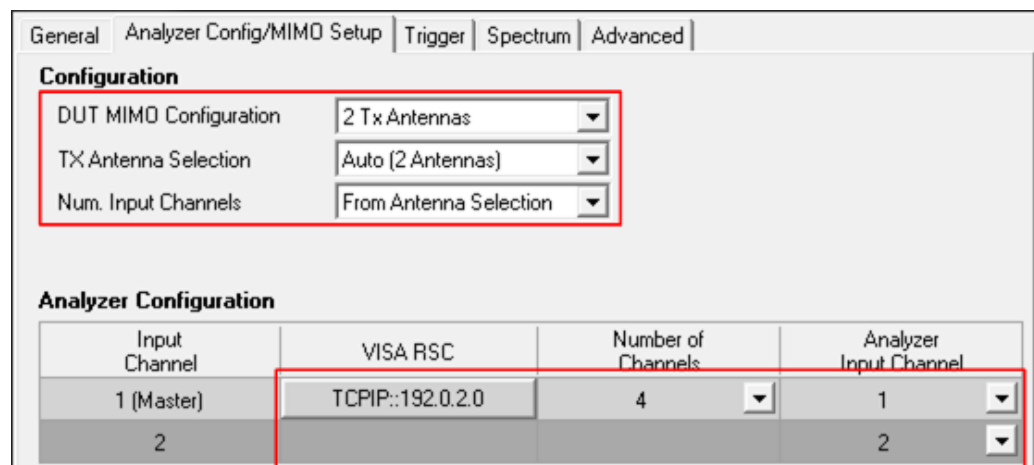

Fig. 8-6: Configuration of the R&S RTO connection and input channels

For configuring the number of active R&S RTO inputs the DUT MIMO configuration (2 Tx antennas or 4 Tx antennas) and the "Tx Antenna Selection" must be set. The DUT MIMO configuration describes which antennas are available and the Tx antenna selection defines how many I/Q data streams are captured and which antennas are assigned to the streams. To measure more than one antenna at once, "Tx Antenna Selection" must be set to "All", "Auto (2 Antennas)" or "Auto (4 Antennas)".

- "All": all available Tx antennas are measured and the antennas are assigned to the streams in ascending order.
- "Auto": the antenna assignment is automatically detected.
In case of "Auto (2 Antennas)" two streams are captured.
In case of "Auto (4 Antennas)" four streams are captured.

The signal level of each R&S RTO input channel is measured and the reference level and attenuation settings are adjusted automatically. If a manual setting is preferred and for speed optimization, the automatic level adjustment can be disabled in the "General" tab of the "General Settings" dialog box.

8.5 Calibrating Beamforming Measurements

The quality of beamforming transmission depends on the phase characteristics of the transmission, because phase errors lead to an incorrect beamforming pattern. Thus, measuring the phase difference between the transmit antennas is the most important task regarding beamforming.

The precision of beamforming phase measurements relies on the phase characteristics of the measurement equipment (cables, oscilloscope etc.). These phase characteristics should be considered in the test setup, otherwise measurement results could be affected by errors. Therefore, it is recommended to calibrate beamforming measurements before performing the actual measurement, and thus improve the precision of the measurement.

The software provides functionality that allows you to correct the measurement results by phase errors resulting from the measurement equipment.

Required equipment

Calibrating beamforming phase measurements requires the following equipment.

- An R&S RTO with four channels.
Note: All data streams have to be measured on a single oscilloscope. Signal analyzers and oscilloscopes with less than four channels are not supported for the calibration.
Calibration is only valid for a particular test setup. If you replace measurement equipment, calibration becomes invalid and you have to recalibrate the test setup.
- An Rohde & Schwarz signal generator (R&S SMBV or similar) equipped with the LTE option.
- An RF splitter (4-way or 2-way).

- Optional: an attenuator between cable and oscilloscope to improve the matching impedance. Improving the matching impedance improves the accuracy of the results even more.

Preparing the calibration measurement

The software creates the calibration data from an LTE signal that you can generate with an Rohde & Schwarz signal generator.

To get the signal, preset the signal generator and select the appropriate channel bandwidth for the beamforming phase measurement. All other settings should remain the same. However, make sure that the signal contains the antenna port 0 of the reference signal.

When done, configure the LTE measurement software with the settings required for the beamforming measurement. Note that after calibration is done, you must not change several parameters (see below).

Setting up the measurement equipment

Now that the generator and software are configured properly, feed the signal into the oscilloscope through an RF splitter.

If you are using a 4-way RF splitter with four data streams, calibration can be done in one go. If you are using a 2-way splitter with four data streams, you have to calibrate each input channel and cable separately (→ start the calibration, select the splitter type from the dialog box and follow the instructions).

Optionally, you can connect an attenuator to each oscilloscope channel and thus improve matching impedance.

Generating new calibration data

- ▶ Start the calibration with the "Generate Calibration Data" softkey. The software performs a single measurement to calculate the correction values.
Note: If you are using a 2-way splitter, calibration consists of several measurements, one for each antenna. After each measurement, you have to connect the signal to a different input channel.

After the calibration measurement is done, you can save the calibration file. This can be useful if you want to use the same equipment again later on. The calibration file has the extension `.cal`. It contains the following parameters that will be restored if you use the calibration file again.

- Center frequency
- Reference level during calibration
- MIMO configuration (number of antennas and number of input channels)
- LTE bandwidth

If you do not save the calibration data, calibration becomes invalid when you change one of the parameters mentioned above or use different equipment (oscilloscope,

cables etc.). The current calibration state is displayed in a status bar at the top of the user interface.

Remote command:

`CALibration:PHASe:GENerate` on page 149

Restoring previously recorded calibration data

If you have previously saved calibration data, you can restore it later on without having to recalibrate the measurement.

- ▶ Load the previously recorded file via drag and drop or the "Load Calibration Data" softkey.
The software restores the frequency, reference level, MIMO configuration and LTE bandwidth that were active during calibration.
Note: Auto leveling is cancelled if you restore calibration data. Instead the reference level is set to the value stored in the calibration file.

Remote command:

`CALibration:PHASe:LOAD` on page 149

Performing beamforming phase measurement

After you are done calibrating the measurement, you can configure the actual phase measurement. Except for the parameters saved in the calibration file, you can change settings and configure the signal as required.

When all is set up, perform the actual measurement. The software corrects the UE RS Weights Phase Difference and Cell RS Weights Phase Difference result display based on the calibration data.

8.6 Performing Time Alignment Measurements

The measurement software allows you to perform Time Alignment measurements between different antennas.

You can perform this measurement in 2 or 4 Tx antenna MIMO setups.

The result of the measurement is the Time Alignment Error. The Time Alignment Error is the time offset between a reference antenna (for example antenna 1) and another antenna.

The Time Alignment Error results are summarized in the corresponding result display.

A schematic description of the results is provided in [figure 8-7](#).

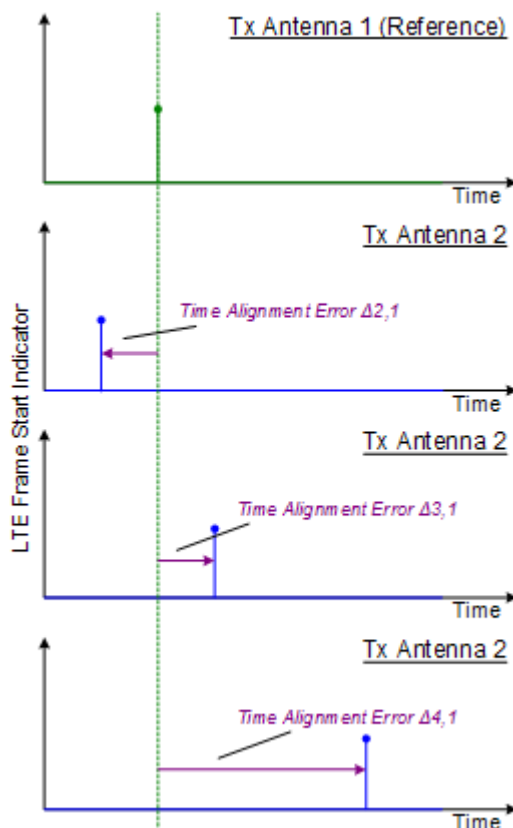

Fig. 8-7: Time Alignment Error (4 Tx antennas)

Test setup

Successful Time Alignment measurements require a correct test setup.

A typical hardware test setup is shown in [figure 8-8](#). Note that the dashed connections are only required for MIMO measurements on 4 Tx antennas.

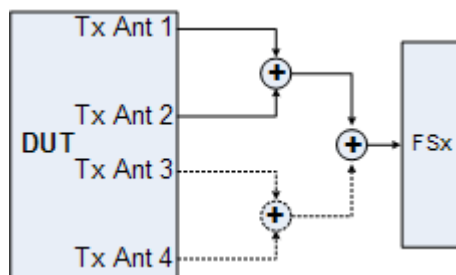

Fig. 8-8: Hardware setup

For best measurement result accuracy it is recommended to use cables of the same length and identical combiners as adders.

In the software, make sure to correctly apply the following settings.

- select a reference antenna in the [MIMO Configuration](#) dialog box (**not** "All")
- set the [Subframe Selection](#) to "All"

- Note that the Time Alignment measurement only evaluates the reference signal and therefore ignores any PDSCH settings - for example, it does not have an influence on this measurement if the PDSCH MIMO scheme is set to transmit diversity or spatial multiplexing.

Time Alignment measurements with carrier aggregation

The test setup per component carrier is basically the same as measurements on a single carrier. You should, however, follow these guidelines for the best measurement results.

- Perform the measurement with an R&S RTO. Compared to an analyzer, the oscilloscope yields more accurate results in this case.
- If you perform the measurement with two analyzers, one analyzer is the master analyzer, the other is the slave. In that case, use the External Reference to synchronize the analyzers and use a trigger to make sure that the measurement starts at the same time on both analyzers. For a more comprehensive description of this test setup see [chapter 8.4.1, "MIMO Measurements with Signal Analyzers"](#), on page 131.
- Use a combiner to combine antennas for each carrier (as shown in [figure 8-8](#)).

8.7 Performing Transmit On/Off Power Measurements

The technical specification in 3GPP TS 36.141 prescribes the measurement of the transmitter OFF power and the transmitter transient period of an EUTRA/LTE TDD base transceiver station (BTS) operating at its specified maximum output power. A special hardware setup is required for this measurement since the actual measurement is done at very low power during the transmitter OFF periods requiring low attenuation at the analyzer input. The signal power during the transmitter ON periods in this test scenario is usually higher than the specified maximum input power of the R&S FSx signal analyzer and will cause severe damage to the analyzer if the measurement is not set up appropriately.

Test setup

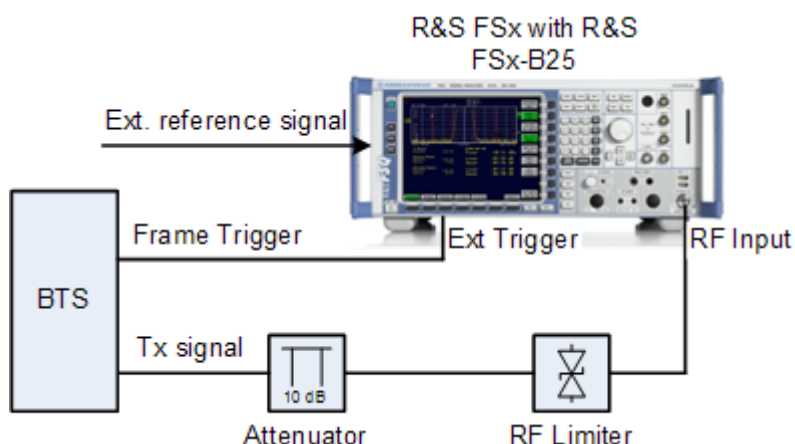

To protect the analyzer input from damage, an RF limiter has to be applied at the analyzer input connector, as can be seen in figure 2-16. Table 1.1 shows the specifications the used limiter has to fulfill.

Min. acceptable CW input power	BTS output power minus 10 dB
Min. acceptable peak input power	BTS peak output power minus 10 dB
Max. output leakage	20 dBm
Max. response time	1 μ s
Max. recovery time	1 μ s

An additional 10 dB attenuation should be placed in front of the RF limiter to absorb eventual reflected waves because of the high VSWR of the limiter. The allowed maximum CW input power of the attenuator must be lower than the maximum output power of the BTS.

Performing the measurement

For the transmit ON/OFF power measurements according to 36.141, 6.4, the test model E-TM1.1 has to be used. For more information on loading the test model settings see [chapter 7, "Data Management"](#), on page 122.

If an external trigger is used, before the actual measurement can be started, the timing must be adjusted by pressing the 'Adjust Timing' hotkey. The status display in the header of the graph changes from 'Timing not adjusted' to 'Timing adjusted' and the run hotkeys are released. Relevant setting changes again lead to a 'Timing not adjusted' status display.

If the adjustment fails, an error message is shown and the adjustment state is still "not adjusted". To find out what causes the synchronization failure, you should perform a regular EVM measurement (i.e. leave the ON/OFF Power measurement). Then you can use all the measurement results like EVM vs. Carrier to get more detailed information about the failure. The timing adjustment will succeed if the Sync State in the header is OK.

Using a R&S FSQ or R&S FSG it is recommended to use the external trigger mode since for high power signals a successful synchronization is not guaranteed under certain circumstances.

Pressing the 'Run Single' hotkey starts the averaging of the traces of the number of frames given in the 'General Settings' dialog. After performing all sweeps, the table in the upper half of the screen shows if the measurements pass or fail.

9 Remote Commands

When working via remote control, note that you have to establish a connection between your remote scripting tool and the software. Because the software runs directly on the PC and not an R&S instrument, you have to connect the remote scripting tool to your PC and not an instrument.

1. Start the software.
2. If you want to capture I/Q data from an analyzer, connect the software to that analyzer.
3. Start the remote scripting tool (e.g. Matlab) on the PC.
4. Connect the remote scripting tool to the local host (e.g. `TCPIC:LocalHost`)

- [Overview of Remote Command Suffixes](#)..... 142
- [Introduction](#)..... 143
- [Remote Commands to Select a Result Display](#)..... 147
- [Remote Commands to Perform Measurements](#)..... 148
- [Remote Commands to Read Numeric Results](#)..... 151
- [Remote Commands to Read Trace Data](#)..... 158
- [Remote Commands to Configure General Settings](#)..... 181
- [Remote Command to Configure the Demodulation](#)..... 199
- [Configuring the Software](#).....225
- [Managing Files](#).....226

9.1 Overview of Remote Command Suffixes

This chapter provides an overview of all suffixes used for remote commands in the LTE application.

Suffix	Range	Description
<allocation>	0 to 99	Selects an allocation.
<instrument>	1 to 8	Selects an instrument for MIMO measurements.
<antenna>	2 to 4	Selects an antenna for MIMO measurements.
<cci>	1 to 2	Selects a component carrier
<cluster>	1 to 2	Selects a cluster (uplink only).
<cwnum>	1 to n	Selects a codeword.
<k>		Selects a limit line. Irrelevant for the LTE software.

Suffix	Range	Description
<m>		Selects a marker. Irrelevant for the LTE software.
<n>	1 to 4	Selects a measurement window.
<subframe>	0 to 39	Selects a subframe.
<t>		Selects a trace. Irrelevant for the LTE application.

9.2 Introduction

Commands are program messages that a controller (e.g. a PC) sends to the instrument or software. They operate its functions ('setting commands') and request information ('query commands'). Some commands only work either way (setting only, query only), others work both ways (setting and query).

The syntax of a SCPI command consists of a so-called header and, in most cases, one or more parameters. A query command must append a question mark after the last header element, even if it contains a parameter.

A header contains one or more keywords, separated by a colon. Header and parameters are separated by a "white space" (ASCII code 0 to 9, 11 to 32 decimal, e.g. blank). If there is more than one parameter for a command, these are separated by a comma from one another.

This chapter summarizes the most important characteristics that you need to know when working with SCPI commands. For a more complete description, refer to the manual of one of the R&S analyzers.



Remote command examples

Note that some remote command examples mentioned in this introductory chapter may not be supported by this application.

9.2.1 Long and Short Form

The keywords have a long and a short form. You can use either the long or the short form, but no other abbreviations of the keywords.

The short form is emphasized in upper case letter. Note however, that this emphasis only serves the purpose to distinguish the short from the long form in the manual. For the instrument, the case does not matter.

Example:

SENSe:FREQuency:CENTer is the same as SENS:FREQ:CENT.

9.2.2 Numeric Suffixes

Some keywords have a numeric suffix if the command can be applied to multiple instances of an object. In that case, the suffix selects a particular instance (e.g. a measurement window).

Numeric suffixes are indicated by angular brackets (<n>) next to the keyword.

If you don't use a suffix for keywords that support one, it is treated as a 1.

Example:

DISPlay[:WINDow<1...4>]:ZOOM:STATe enables the zoom in a particular measurement window, selected by the suffix at WINDow.

DISPlay:WINDow4:ZOOM:STATe ON refers to window 4.

9.2.3 Optional Keywords

Some keywords are optional and are only part of the syntax because of SCPI compliance. You can include them in the header or not.

Note that if an optional keyword has a numeric suffix and you need to use the suffix, you have to include the optional keyword. Otherwise, the suffix is recognized as a 1.

Optional keywords are emphasized with square brackets.

Example:

Without a numeric suffix in the optional keyword:

[SENSe:]FREQuency:CENTer is the same as FREQuency:CENTer

With a numeric suffix in the optional keyword:

DISPlay[:WINDow<1...4>]:ZOOM:STATe

DISPlay:ZOOM:STATe ON enables the zoom in window 1 (no suffix).

DISPlay:WINDow4:ZOOM:STATe ON enables the zoom in window 4.

9.2.4 | (Vertical Stroke)

A vertical stroke indicates alternatives for a specific keyword. You can use both keywords to the same effect.

Example:

[SENSe:]BANDwidth|BWIDth[:RESolution]

In the short form without optional keywords, BAND 1MHZ would have the same effect as BWID 1MHZ.

9.2.5 SCPI Parameters

Many commands feature one or more parameters.

If a command supports more than one parameter, these are separated by a comma.

Example:

```
LAYout:ADD:WINDow Spectrum,LEFT,MTABLE
```

Parameters may have different forms of values.

- [Numeric Values](#)..... 145
- [Boolean](#)..... 146
- [Text](#)..... 146
- [Character Strings](#)..... 146
- [Block Data](#)..... 146

9.2.5.1 Numeric Values

Numeric values can be entered in any form, i.e. with sign, decimal point or exponent. In case of physical quantities, you can also add the unit. If the unit is missing, the command uses the basic unit.

Example:

with unit: `SENSe:FREQuency:CENTer 1GHZ`

without unit: `SENSe:FREQuency:CENTer 1E9` would also set a frequency of 1 GHz.

Values exceeding the resolution of the instrument are rounded up or down.

If the number you have entered is not supported (e.g. in case of discrete steps), the command returns an error.

Querying numeric values

When you query numeric values, the system returns a number. In case of physical quantities, it applies the basic unit (e.g. Hz in case of frequencies). The number of digits after the decimal point depends on the type of numeric value.

Example:

Setting: `SENSe:FREQuency:CENTer 1GHZ`

Query: `SENSe:FREQuency:CENTer?` would return `1E9`

In some cases, numeric values may be returned as text.

- `INF/NINF`
Infinity or negative infinity. Represents the numeric values `9.9E37` or `-9.9E37`.
- `NAN`
Not a number. Represents the numeric value `9.91E37`. `NAN` is returned in case of errors.

9.2.5.2 Boolean

Boolean parameters represent two states. The "ON" state (logically true) is represented by "ON" or a numeric value 1. The "OFF" state (logically untrue) is represented by "OFF" or the numeric value 0.

Querying boolean parameters

When you query boolean parameters, the system returns either the value 1 ("ON") or the value 0 ("OFF").

Example:

Setting: `DISPlay:WINDow:ZOOM:STATe ON`

Query: `DISPlay:WINDow:ZOOM:STATe?` would return 1

9.2.5.3 Text

Text parameters follow the syntactic rules of keywords. You can enter text using a short or a long form. For more information see [chapter 9.2.1, "Long and Short Form"](#), on page 143.

Querying text parameters

When you query text parameters, the system returns its short form.

Example:

Setting: `SENSe:BANDwidth:RESolution:TYPE NORMAl`

Query: `SENSe:BANDwidth:RESolution:TYPE?` would return NORM

9.2.5.4 Character Strings

Strings are either text or number. They have to be in straight quotation marks. You can use a single quotation mark - ' - or a double quotation mark - " -.

Example:

`INSTRument:DELeTe 'Spectrum'`

9.2.5.5 Block Data

Block data is a format which is suitable for the transmission of large amounts of data.

The ASCII character # introduces the data block. The next number indicates how many of the following digits describe the length of the data block. In the example the 4 following digits indicate the length to be 5168 bytes. The data bytes follow. During the transmission of these data bytes all end or other control signs are ignored until all bytes are transmitted. #0 specifies a data block of indefinite length. The use of the indefinite format requires a `NL^END` message to terminate the data block. This format is useful

when the length of the transmission is not known or if speed or other considerations prevent segmentation of the data into blocks of definite length.

9.3 Remote Commands to Select a Result Display

CALCulate<n>:FEED.....	147
DISPlay[:WINDow<n>]:TABLe.....	148

CALCulate<n>:FEED <DispType>

This command selects the measurement and result display.

Parameters:

<DispType> String containing the short form of the result display. See table below for details.

Example:

```
CALC2:FEED 'PVT:CBUF'
```

Select Capture Buffer to be displayed on screen B.

Result display	Parameter
ACLR	'SPEC:ACP'
Allocation ID vs Symbol x Carrier	'STAT:AISC'
Allocation Summary	'STAT:ASUM'
Beamform Allocation Summary	'BEAM:URWA'
Bitstream	'STAT:BSTR'
Capture Buffer	'PVT:CBUF'
CCDF	'STAT:CCDF'
Cell RS Weights (Phase)	'BEAM:CRWP'
Cell RS Weights Difference (Phase)	'BEAM:CRPD'
Channel Decoder	'STAT:CDR'
Constellation Diagram	'CONS:CONS'
CSI RS Weights (Magnitude)	'BEAM:IRWM'
CSI RS Weights (Phase)	'BEAM:IRWP'
EVM vs Carrier	'EVM:EVCA'
EVM vs RB	'EVM:EVRP'
EVM vs Subframe	'EVM:EVSU'
EVM vs Symbol	'EVM:EVSY'
EVM vs Symbol x Carrier	'EVM:EVSC'
Flatness Difference	'SPEC:FLAT'
Frequency Error vs Symbol	'EVM:FEVS'

Result display	Parameter
Group Delay	'SPEC:GDEL'
On / Off Power	'PVT:OOP'
Power Spectrum	'SPEC:PSPE'
Power vs RB PDSCH	'SPEC:PVRP'
Power vs RB RS	'SPEC:PVRR'
Power vs Symbol x Carrier	'SPEC:PVSC'
Spectrum Flatness	'SPEC:FLAT'
Signal Flow	'STAT:SFLO'
Spectrum Emission Mask	'SPEC:SEM'
Time Alignment Error	'PVT:TAER'
UE RS Weights (Magnitude)	'BEAM:URWM'
UE RS Weights (Phase)	'BEAM:URWP'
UE RS Weights Difference (Magnitude)	'BEAM:URMD'
UE RS Weights Difference (Phase)	'BEAM:URPD'

DISPlay[:WINDow<n>]:TABLe <State>

This command turns the result summary on and off.

Parameters:

<State>

ON

Turns the result summary on and removes all graphical results from the screen.

OFF

Turns the result summary off and restores the graphical results that were previously set.

Example:

```
DISP:TABL OFF
```

Turns the result summary off.

9.4 Remote Commands to Perform Measurements

CALibration:PHASe:GENerate.....	149
CALibration:PHASe:LOAD.....	149
INITiate[:IMMediate].....	149
INITiate:REFResh.....	149
[SENSe]:SYNC[:STATe]?.....	150
[SENSe][:LTE]:OOPower:ATIMing.....	150
CONFigure[:LTE]:DL:CONS:LOCation.....	150
CONFigure[:LTE]:DL:BF:AP.....	150

CALibration:PHASe:GENerate <Path>

This command generates calibration data for beamforming measurements and saves it to a file.

Setting parameters:

<Path> String containing the path and name of the calibration file.

Example: CAL:PHAS:GEN 'C:\calibration.cal'
Generates calibration data and saves it to a file.

Usage: Setting only

CALibration:PHASe:LOAD <Path>

This command restores a calibration file for beamforming measurements that you have previously created.

Setting parameters:

<Path> String containing the path and name of the calibration file.

Example: CAL:PHAS:LOAD 'C:\calibration.cal'
Restores the calibration data.

Usage: Setting only

INITiate[:IMMEDIATE]

This command initiates a new measurement sequence.

With a frame count > 0, this means a restart of the corresponding number of measurements.

In single sweep mode, you can synchronize to the end of the measurement with *OPC. In continuous sweep mode, synchronization to the end of the sweep is not possible.

Example: INIT
Initiates a new measurement.

Usage: Event

INITiate:REFresh

This command updates the current I/Q measurement results to reflect the current measurement settings.

No new I/Q data is captured. Thus, measurement settings apply to the I/Q data currently in the capture buffer.

The command applies exclusively to I/Q measurements. It requires I/Q data.

Example: INIT:REFR
The application updates the IQ results

Usage: Event

[SENSe]:SYNC[:STATe]?

This command queries the current synchronization state.

Return values:

<State>

The string contains the following information.

- <OFDMSymbolTiming> is the coarse symbol timing
- <P-SYNCSynchronization> is the P-SYNC synchronization state
- <S-SYNCSynchronization> is the S-SYNC synchronization state

A zero represents a failure and a one represents a successful synchronization.

If no compatible frame has been found, the command returns '0,0,0'.

Example:

SYNC:STAT?

Would return, e.g. '1,1,0' if coarse timing and P-SYNC were successful but S-SYNC failed.

Usage:

Query only

[SENSe][:LTE]:OOPower:ATIMing

This command adjusts the timing for On/Off Power measurements.

Example:

OOP:ATIM

Adjusts the On/Off Power timing.

Usage:

Event

CONFigure[:LTE]:DL:CONS:LOCation <Location>

This command selects the data source of the constellation diagram for measurements on downlink signals.

Parameters:

<Location>

AMD

After the MIMO decoder

BMD

Before the MIMO decoder

*RST: BMD

Example:

CONF:DL:CONS:LOC AMD

Use data from after the MIMO decoder.

CONFigure[:LTE]:DL:BF:AP <Port>

This command selects the antenna port for beamforming measurements.

The availability of ports depends on the number of transmit antennas and number of beamforming layers.

Parameters:

<Port>	AP5715 (antenna ports 5, 7, 15)
	AP816 (antenna ports 8, 16)
	AP917 (antenna ports 9, 17)
	AP1018 (antenna ports 10, 18)
	AP1119 (antenna ports 11, 19)
	AP1220 (antenna ports 12, 20)
	AP1321 (antenna ports 13, 21)
	AP1422 (antenna ports 14, 22)

Example:

```
CONF:DL:BF:AP AP816
Selects antenna ports 8 and 16.
```

9.5 Remote Commands to Read Numeric Results

FETCh:SUMMary:CRESt:MAXimum?	152
FETCh:SUMMary:CRESt:MINimum?	152
FETCh:SUMMary:CRESt[:AVERage]?	152
FETCh:SUMMary:EVM[:ALL]:MAXimum?	152
FETCh:SUMMary:EVM[:ALL]:MINimum?	152
FETCh:SUMMary:EVM[:ALL][:AVERage]?	152
FETCh:SUMMary:EVM:DSQP:MAXimum?	153
FETCh:SUMMary:EVM:DSQP:MINimum?	153
FETCh:SUMMary:EVM:DSQP[:AVERage]?	153
FETCh:SUMMary:EVM:DSST:MAXimum?	153
FETCh:SUMMary:EVM:DSST:MINimum?	153
FETCh:SUMMary:EVM:DSST[:AVERage]?	153
FETCh:SUMMary:EVM:DSSF:MAXimum?	153
FETCh:SUMMary:EVM:DSSF:MINimum?	153
FETCh:SUMMary:EVM:DSSF[:AVERage]?	153
FETCh:SUMMary:EVM:PCHannel:MAXimum?	154
FETCh:SUMMary:EVM:PCHannel:MINimum?	154
FETCh:SUMMary:EVM:PCHannel[:AVERage]?	154
FETCh:SUMMary:EVM:PSIGnal:MAXimum?	154
FETCh:SUMMary:EVM:PSIGnal:MINimum?	154
FETCh:SUMMary:EVM:PSIGnal[:AVERage]?	154
FETCh:SUMMary:FERRor:MAXimum?	154
FETCh:SUMMary:FERRor:MINimum?	154
FETCh:SUMMary:FERRor[:AVERage]?	154
FETCh:SUMMary:GIMBalance:MAXimum?	155
FETCh:SUMMary:GIMBalance:MINimum?	155
FETCh:SUMMary:GIMBalance[:AVERage]?	155
FETCh:SUMMary:IQOFfset:MAXimum?	155
FETCh:SUMMary:IQOFfset:MINimum?	155
FETCh:SUMMary:IQOFfset[:AVERage]?	155
FETCh:SUMMary:OSTP:MAXimum?	155
FETCh:SUMMary:OSTP:MINimum?	155

FETCh:SUMMary:OSTP[:AVERage]?	155
FETCh:SUMMary:POWer:MAXimum?	156
FETCh:SUMMary:POWer:MINimum?	156
FETCh:SUMMary:POWer[:AVERage]?	156
FETCh:SUMMary:QUADerror:MAXimum?	156
FETCh:SUMMary:QUADerror:MINimum?	156
FETCh:SUMMary:QUADerror[:AVERage]?	156
FETCh[:CC<cci>]:SUMMary:RFERror[:AVERage]?	156
FETCh:SUMMary:RSSI:MAXimum?	157
FETCh:SUMMary:RSSI:MINimum?	157
FETCh:SUMMary:RSSI[:AVERage]?	157
FETCh:SUMMary:RSTP:MAXimum?	157
FETCh:SUMMary:RSTP:MINimum?	157
FETCh:SUMMary:RSTP[:AVERage]?	157
FETCh:SUMMary:SERRor:MAXimum?	157
FETCh:SUMMary:SERRor:MINimum?	157
FETCh:SUMMary:SERRor[:AVERage]?	157
FETCh:SUMMary:TFRame?	157
FETCh:TAERror[:CC<cci>]:ANTenna<antenna>:MAXimum?	158
FETCh:TAERror[:CC<cci>]:ANTenna<antenna>:MINimum?	158
FETCh:TAERror[:CC<cci>]:ANTenna<antenna>[:AVERage]?	158

FETCh:SUMMary:CRESt:MAXimum?
FETCh:SUMMary:CRESt:MINimum?
FETCh:SUMMary:CRESt[:AVERage]?

This command queries the average crest factor as shown in the result summary.

Return values:

<CrestFactor> <numeric value>
 Crest Factor in dB.

Example: FETC:SUMM:CRESt?
 Returns the current crest factor in dB.

Usage: Query only

FETCh:SUMMary:EVM[:ALL]:MAXimum?
FETCh:SUMMary:EVM[:ALL]:MINimum?
FETCh:SUMMary:EVM[:ALL][:AVERage]?

This command queries the EVM of all resource elements.

Return values:

<EVM> <numeric value>
 Minimum, maximum or average EVM, depending on the last
 command syntax element.
 The unit is % or dB, depending on your selection.

Example: FETC:SUMM:EVM?
 Returns the mean value.

Usage: Query only

FETCh:SUMMary:EVM:DSQP:MAXimum?
FETCh:SUMMary:EVM:DSQP:MINimum?
FETCh:SUMMary:EVM:DSQP[:AVERAge]?

This command queries the EVM of all resource elements of the PDSCH with a QPSK modulation.

Return values:

<EVM> <numeric value>
 EVM in % or dB, depending on the unit you have set.

Example: FETC:SUMM:EVM:DSQP?
 Returns the PDSCH QSPK EVM.

Usage: Query only

FETCh:SUMMary:EVM:DSST:MAXimum?
FETCh:SUMMary:EVM:DSST:MINimum?
FETCh:SUMMary:EVM:DSST[:AVERAge]?

This command queries the EVM of all resource elements of the PDSCH with a 16QAM modulation.

Return values:

<EVM> <numeric value>
 EVM in % or dB, depending on the unit you have set.

Example: FETC:SUMM:EVM:DSST?
 Returns the PDSCH 16QAM EVM.

Usage: Query only

FETCh:SUMMary:EVM:DSSF:MAXimum?
FETCh:SUMMary:EVM:DSSF:MINimum?
FETCh:SUMMary:EVM:DSSF[:AVERAge]?

This command queries the EVM of all resource elements of the PDSCH with a 64QAM modulation.

Return values:

<EVM> <numeric value>
 EVM in % or dB, depending on the unit you have set.

Example: FETC:SUMM:EVM:DSSF?
 Returns the PDSCH 64QAM EVM.

Usage: Query only

FETCh:SUMMary:EVM:PCHannel:MAXimum?
FETCh:SUMMary:EVM:PCHannel:MINimum?
FETCh:SUMMary:EVM:PCHannel[:AVERage]?

This command queries the EVM of all physical channel resource elements.

Return values:

<EVM> <numeric value>
 Minimum, maximum or average EVM, depending on the last command syntax element.
 The unit is % or dB, depending on your selection.

Example: FETC : SUMM : EVM : PCH ?
 Returns the mean value.

Usage: Query only

FETCh:SUMMary:EVM:PSIGnal:MAXimum?
FETCh:SUMMary:EVM:PSIGnal:MINimum?
FETCh:SUMMary:EVM:PSIGnal[:AVERage]?

This command queries the EVM of all physical signal resource elements.

Return values:

<EVM> <numeric value>
 Minimum, maximum or average EVM, depending on the last command syntax element.
 The unit is % or dB, depending on your selection.

Example: FETC : SUMM : EVM : PSIG ?
 Returns the mean value.

Usage: Query only

FETCh:SUMMary:FERRor:MAXimum?
FETCh:SUMMary:FERRor:MINimum?
FETCh:SUMMary:FERRor[:AVERage]?

This command queries the frequency error.

Return values:

<FreqError> <numeric value>
 Minimum, maximum or average frequency error, depending on the last command syntax element.
 Default unit: Hz

Example: FETC : SUMM : FERR ?
 Returns the average frequency error in Hz.

Usage: Query only

FETCh:SUMMary:GIMBalance:MAXimum?
FETCh:SUMMary:GIMBalance:MINimum?
FETCh:SUMMary:GIMBalance[:AVERage]?

This command queries the I/Q gain imbalance.

Return values:

<GainImbalance> <numeric value>
 Minimum, maximum or average I/Q imbalance, depending on the last command syntax element.
 Default unit: dB

Example: `FETC:SUMM:GIMB?`
 Returns the current gain imbalance in dB.

Usage: Query only

FETCh:SUMMary:IQOffset:MAXimum?
FETCh:SUMMary:IQOffset:MINimum?
FETCh:SUMMary:IQOffset[:AVERage]?

This command queries the I/Q offset.

Return values:

<IQOffset> <numeric value>
 Minimum, maximum or average I/Q offset, depending on the last command syntax element.
 Default unit: dB

Example: `FETC:SUMM:IQOF?`
 Returns the current IQ-offset in dB

Usage: Query only

FETCh:SUMMary:OSTP:MAXimum?
FETCh:SUMMary:OSTP:MINimum?
FETCh:SUMMary:OSTP[:AVERage]?

This command queries the OSTP.

Return values:

<OSTP> <numeric value>
 Minimum, maximum or average OSTP, depending on the last command syntax element.
 Default unit: dBm

Example: `FETC:SUMM:OSTP?`
 Returns the current average OSTP value.

Usage: Query only

FETCh:SUMMary:POWer:MAXimum?
FETCh:SUMMary:POWer:MINimum?
FETCh:SUMMary:POWer[:AVERage]?

This command queries the total power.

Return values:

<Power> <numeric value>
 Minimum, maximum or average power, depending on the last command syntax element.
 Default unit: dBm

Example: FETC:SUMM:POW?
 Returns the total power in dBm

Usage: Query only

FETCh:SUMMary:QUADerror:MAXimum?
FETCh:SUMMary:QUADerror:MINimum?
FETCh:SUMMary:QUADerror[:AVERage]?

This command queries the quadrature error.

Return values:

<QuadError> <numeric value>
 Minimum, maximum or average quadrature error, depending on the last command syntax element.
 Default unit: deg

Example: FETC:SUMM:QUAD?
 Returns the current mean quadrature error in degrees.

Usage: Query only

FETCh[:CC<cci>]:SUMMary:RFERror[:AVERage]?

This command queries the frequency error of the component carriers.

Return values:

<FrequencyError> Frequency error of the component carrier (CC2) relative to the main component carrier (CC1).
 Default unit: Hz

Example: FETC:SUMM:RFER:AVER?
 Returns the frequency error in Hz.

Usage: Query only

FETCh:SUMMary:RSSI:MAXimum?
FETCh:SUMMary:RSSI:MINimum?
FETCh:SUMMary:RSSI[:AVERage]?

This command queries the RSSI as shown in the result summary.

Return values:

<RSSI> <numeric value>
 Minimum, maximum or average sampling error, depending on
 the last command syntax element.
 Default unit: dBm

Example: FETC:SUMM:RSSI?
 Queries the average RSSI.

Usage: Query only

FETCh:SUMMary:RSTP:MAXimum?
FETCh:SUMMary:RSTP:MINimum?
FETCh:SUMMary:RSTP[:AVERage]?

This command queries the RSTP as shown in the result summary.

Return values:

<RSTP> RSTP in dBm.

Example: FETC:SUMM:RSTP?
 Queries the RSTP.

Usage: Query only

FETCh:SUMMary:SERRor:MAXimum?
FETCh:SUMMary:SERRor:MINimum?
FETCh:SUMMary:SERRor[:AVERage]?

This command queries the sampling error.

Return values:

<SamplingError> <numeric value>
 Minimum, maximum or average sampling error, depending on
 the last command syntax element.
 Default unit: ppm

Example: FETC:SUMM:SERR?
 Returns the current mean sampling error in ppm.

Usage: Query only

FETCh:SUMMary:TFRame?

This command queries the (sub)frame start offset as shown in the Capture Buffer result display.

Return values:

<Offset> Time difference between the (sub)frame start and capture buffer start.

Default unit: s

Example:

FETC:SUMM:TFR?

Returns the (sub)frame start offset.

Usage:

Query only

FETCh:TAERror[:CC<cci>]:ANTenna<antenna>:MAXimum?
FETCh:TAERror[:CC<cci>]:ANTenna<antenna>:MINimum?
FETCh:TAERror[:CC<cci>]:ANTenna<antenna>[:AVERage]?

This command queries the time alignment error.

Return values:

<Time Alignment Error> Minimum, maximum or average time alignment error, depending on the last command syntax element.

Default unit: s

Example:

FETC:TAER:ANT2?

Returns the average time alignment error between the reference antenna and antenna 2 in s.

Usage:

Query only

9.6 Remote Commands to Read Trace Data

- [Using the TRACe\[:DATA\] Command](#)..... 158
- [Reading Out Limit Check Results](#)..... 173

9.6.1 Using the TRACe[:DATA] Command

This chapter contains information on the TRACe:DATA command and a detailed description of the characteristics of that command.

The TRACe:DATA command queries the trace data or results of the currently active measurement or result display. The type, number and structure of the return values are specific for each result display. In case of results that have any kind of unit, the command returns the results in the unit you have currently set for that result display.

Note also that return values for results that are available for both downlink and uplink may be different.

For several result displays, the command also supports various SCPI parameters in combination with the query. If available, each SCPI parameter returns a different aspect of the results. If SCPI parameters are supported, you have to quote one in the query.

Example:

```
TRAC2:DATA? TRACE1
```

The format of the return values is either in ASCII or binary characters and depends on the format you have set with `FORMat [:DATA]`.

Following this detailed description, you will find a short summary of the most important functions of the command (`TRACe [:DATA] ?`).

• Adjacent Channel Leakage Ratio.....	159
• Allocation ID vs Symbol x Carrier.....	160
• Allocation Summary.....	160
• Beamform Allocation Summary.....	161
• Bit Stream.....	161
• Capture Buffer.....	162
• CCDF.....	162
• Cell RS Weights Phase (Difference).....	162
• Channel Decoder Results.....	163
• Channel and Spectrum Flatness.....	164
• Channel and Spectrum Flatness Difference.....	164
• Channel Group Delay.....	164
• Constellation Diagram.....	165
• CSI RS Weights Magnitude.....	165
• CSI RS Weights Phase.....	166
• EVM vs Carrier.....	166
• EVM vs RB.....	166
• EVM vs Subframe.....	167
• EVM vs Symbol.....	167
• EVM vs Symbol x Carrier.....	167
• Frequency Error vs Symbol.....	167
• On/Off Power.....	168
• Power Spectrum.....	168
• Power vs RB RS.....	168
• Power vs RB PDSCH.....	169
• Power vs Symbol x Carrier.....	169
• Spectrum Emission Mask.....	169
• UE RS Weights Magnitude (Difference).....	170
• UE RS Weights Phase (Difference).....	170
• Return Value Codes.....	170

9.6.1.1 Adjacent Channel Leakage Ratio

For the ACLR result display, the number and type of returns values depend on the parameter.

- TRACE1
Returns one value for each trace point of trace 1 (yellow). Trace 1 contains the absolute power values measured with a 1 MHz RBW.
<absolute power>, ...
The unit is always dBm.

- **TRACE2**
Returns one value for each trace point of trace 2 (green). Trace 2 contains the absolute power values measured with a 100 kHz RBW. TRACE2 is available for relative ACLR measurements.
- **LIST**
Returns the contents of the ACLR table.
For each channel, it returns six values.
<bandwidth>, <spacing offset>, <power>, <delta to limit>, <frequency at delta to limit>, <limit check result>, ...
The channel order is: TX channel → lower adjacent → upper adjacent → lower alternate → upper alternate
The unit of the <bandwidth>, <spacing offset> and <frequency at delta to limit> is Hz.
The unit of the power is either dBc or dBm, depending on the ACLR measurement mode (relative or absolute).
The <limit check result> is either a 0 (for PASS) or a 1 (for FAIL).
Note that the TX channel does not have a <spacing offset>, <delta to limit>, <frequency at delta to limit> and <limit check result>. NaN is returned instead.

9.6.1.2 Allocation ID vs Symbol x Carrier

For the Allocation ID vs Symbol x Carrier, the command returns one value for each resource element.

```
<ID[Symbol(0),Carrier(1)]>, ..., <ID[Symbol(0),Carrier(n)]>,
<ID[Symbol(1),Carrier(1)]>, ..., <ID[Symbol(1),Carrier(n)]>,
...
```

```
<ID[Symbol(n),Carrier(1)]>, ..., <ID[Symbol(n),Carrier(n)]>
```

The <allocation ID> is encoded. For the code assignment see [chapter 9.6.1.30, "Return Value Codes"](#), on page 170.

The following parameters are supported.

- TRACE1

9.6.1.3 Allocation Summary

For the Allocation Summary, the command returns seven values for each line of the table.

```
<subframe>, <allocation ID>, <number of RB>, <relative power>,
<modulation>, <absolute power>, <EVM>, ...
```

The unit for <absolute power> is always dBm. The unit for <relative power> is always dB. The unit for <EVM> depends on [UNIT:EVM](#). All other values have no unit.

The <allocation ID> and <modulation> are encoded. For the code assignment see [chapter 9.6.1.30, "Return Value Codes"](#), on page 170.

Note that the data format of the return values is always ASCII.

Example:

Allocation Summary		Selection		Antenna: 1			
Sub-frame	Alloc. ID	Number of RB	Rel. Power/dB	Modulation	Power per RE/dBm	EVM/%	
0	RS Ant1		0,000	QPSK	-45,546	0,733	
	P-SYNC		-0,007	CAZAC	-42,558	0,254	
	S-SYNC		0,005	RBPSK	-42,546	0,251	

TRAC:DATA? TRACE1 would return:

```
0, -5, 0, 0.00000000000000, 2, -45.5463829153428, 7.33728660354122E-05,
0, -3, 0, 0.0073997452251, 6, -42.5581007463452, 2.54197349219455E-05,
0, -4, 0, 0.0052647197362, 1, -42.5464220485716, 2.51485275782241E-05,
...
```

9.6.1.4 Beamform Allocation Summary

For the Beamform Allocation Summary result display, the command returns four values for each allocation that has been found.

<Subframe>, <AllocationID>, <Phase>, <PhaseDifference>, ...

The unit for <Phase> and <PhaseDifference> is always degrees. The <Subframe> has no unit.

The <allocation ID> is encoded. For the code assignment see [chapter 9.6.1.30, "Return Value Codes"](#), on page 170.

9.6.1.5 Bit Stream

For the Bit Stream result display, the command returns five values and the bitstream for each line of the table.

<subframe>, <allocation ID>, <codeword>, <modulation>, <# of symbols/bits>, <hexadecimal/binary numbers>, ...

All values have no unit. The format of the bitstream depends on [Bit Stream Format](#).

The <allocation ID>, <codeword> and <modulation> are encoded. For the code assignment see [chapter 9.6.1.30, "Return Value Codes"](#), on page 170.

For symbols or bits that are not transmitted, the command returns

- "FFF" if the bit stream format is "Symbols"
- "9" if the bit stream format is "Bits".

For symbols or bits that could not be decoded because the number of layer exceeds the number of receive antennas, the command returns

- "FFE" if the bit stream format is "Symbols"
- "8" if the bit stream format is "Bits".

Note that the data format of the return values is always ASCII.

Example:

Sub-frame	Allocation ID	Code-word	Modulation	Symbol Index	Bit Stream
0	PBCH	1/1	QPSK	0	01 01 00 02 03 00 01 02 01 02 01 00 03 00 02 02
0	PBCH	1/1	QPSK	16	02 03 02 03 03 03 00 02 00 03 00 02 02 03 01 01
0	PBCH	1/1	QPSK	32	03 02 03 03 03 03 01 03 00 03 00 03 03 00 03 02

TRAC:DATA? TRACE1 would return:

```
0, -12, 0, 2, 0, 01, 01, 00, 02, 03, 00, 01, 02, 01, 02, 01, ...
<continues like this until the next data block starts or the end of data is
reached>
0, -12, 0, 2, 32, 03, 02, 03, 03, 03, 03, 01, 03, 00, 03, ...
```

9.6.1.6 Capture Buffer

For the Capture Buffer result display, the command returns one value for each I/Q sample in the capture buffer.

<absolute power>, ...

The unit is always dBm.

The following parameters are supported.

- TRACE1

9.6.1.7 CCDF

For the CCDF result display, the type of return values depends on the parameter.

- TRACE1
Returns the probability values (y-axis).
<# of values>, <probability>, ...
The unit is always %.
The first value that is returned is the number of the following values.
- TRACE2
Returns the corresponding power levels (x-axis).
<# of values>, <relative power>, ...
The unit is always dB.
The first value that is returned is the number of the following values.

9.6.1.8 Cell RS Weights Phase (Difference)

For the Cell RS Weights Magnitude and Cell RS Weights Magnitude Difference result display, the command returns one value for each subcarrier that has been analyzed.

<Phase>, ...

The unit degree.

The following parameters are supported.

- TRACE1
Returns the phase of the measured weights of the reference signal (RS) carriers over one subframe.

9.6.1.9 Channel Decoder Results

For the Channel Decoder Results, the number and type of return values depend on the parameter.

- PBCH
Returns the results for the PBCH if PBCH decoding (or CRC check) was successful. The results are made up out of six values.
<subframe>, <# of antennas>, <system bandwidth>, <frame>, <PHICH duration>, <PHICH resource>
The unit for <system bandwidth> is Hz. All other values have no unit.
The <PHICH duration> and <PHICH resource> are encoded. For the code assignment see [chapter 9.6.1.30, "Return Value Codes"](#), on page 170.
If PBCH decoding was not successful, the command returns NAN.
- PCFICH
Returns the results for the PCFICH. The results are made up out of two parameters.
<subframe>, <number of symbols for PDCCH>
The values have no unit.
- PHICH
Returns the results for the PHICH. The results are made up out of three values for each line of the table.
<subframe>, <ACK/NACK>, <relative power>
The unit for <relative power> is dB. All other values have no unit.
The <ACK/NACK> is encoded. For the code assignment see [chapter 9.6.1.30, "Return Value Codes"](#), on page 170.
- PDCCH
Returns the results for the PDCCH. The results are made up out of seven values for each line of the table.
<subframe>, <RNTI>, <DCI format>, <PDCCH format>, <CCE offset>, <# of transmitted bits>, [stream of binary numbers]
The values have no unit.
The [stream of binary numbers] is a list of binary numbers separated by comma.
The <DCI format> and <PDCCH format> are encoded. For the code assignment see [chapter 9.6.1.30, "Return Value Codes"](#), on page 170.
- PDSCH
Returns the results for the PDSCH. The results are made up out of five values for each line of the table.
<subframe>, <allocationID>, <codeword>, <# of transmitted bits>, [stream of binary numbers]
The values have no unit.

The [stream of binary numbers] is a list of binary numbers separated by comma.

If the PDSCH could not be decoded, the NAN is returned instead of the <# of transmitted bits>. The [stream of binary numbers] is not shown.

The <allocationID> and <codeword> are encoded. For the code assignment see [chapter 9.6.1.30, "Return Value Codes"](#), on page 170.

9.6.1.10 Channel and Spectrum Flatness

For the Channel Flatness result display, the command returns one value for each trace point.

<relative power>, ...

The unit is always dB.

The following parameters are supported.

- TRACE1
Returns the average power over all subframes.
- TRACE2
Returns the minimum power found over all subframes. If you are analyzing a particular subframe, it returns nothing.
- TRACE3
Returns the maximum power found over all subframes. If you are analyzing a particular subframe, it returns nothing.

9.6.1.11 Channel and Spectrum Flatness Difference

For the Channel Flatness Difference result display, the command returns one value for each trace point.

<relative power>, ...

The unit is always dB. The number of values depends on the selected LTE bandwidth.

The following parameters are supported.

- TRACE1
Returns the average power over all subframes.
- TRACE2
Returns the minimum power found over all subframes. If you are analyzing a particular subframe, it returns nothing.
- TRACE3
Returns the maximum power found over all subframes. If you are analyzing a particular subframe, it returns nothing.

9.6.1.12 Channel Group Delay

For the Channel Group Delay result display, the command returns one value for each trace point.

<group delay>, ...

The unit is always ns. The number of values depends on the selected LTE bandwidth.

The following parameters are supported.

- TRACE1
Returns the group delay.

9.6.1.13 Constellation Diagram

For the Constellation Diagram, the command returns two values for each constellation point.

```
<I[SF0][Sym0][Carrier1]>, <Q[SF0][Sym0][Carrier1]>, ..., <I[SF0][Sym0][Carrier(n)]>, <Q[SF0][Sym0][Carrier(n)]>,
<I[SF0][Sym1][Carrier1]>, <Q[SF0][Sym1][Carrier1]>, ..., <I[SF0][Sym1][Carrier(n)]>, <Q[SF0][Sym1][Carrier(n)]>,
<I[SF0][Sym(n)][Carrier1]>, <Q[SF0][Sym(n)][Carrier1]>, ..., <I[SF0][Sym(n)][Carrier(n)]>, <Q[SF0][Sym(n)][Carrier(n)]>,
<I[SF1][Sym0][Carrier1]>, <Q[SF1][Sym0][Carrier1]>, ..., <I[SF1][Sym0][Carrier(n)]>, <Q[SF1][Sym0][Carrier(n)]>,
<I[SF1][Sym1][Carrier1]>, <Q[SF1][Sym1][Carrier1]>, ..., <I[SF1][Sym1][Carrier(n)]>, <Q[SF1][Sym1][Carrier(n)]>,
<I[SF(n)][Sym(n)][Carrier1]>, <Q[SF(n)][Sym(n)][Carrier1]>, ..., <I[SF(n)][Sym(n)][Carrier(n)]>, <Q[SF(n)][Sym(n)][Carrier(n)]>
```

With SF = subframe and Sym = symbol of that subframe.

The I and Q values have no unit.

The number of return values depends on the constellation selection. By default, it returns all resource elements including the DC carrier.

The following parameters are supported.

- TRACE1
Returns all constellation points included in the selection.

9.6.1.14 CSI RS Weights Magnitude

For the CSI RS Weights Magnitude result display, the command returns one value for each subcarrier that has been analyzed.

<Magnitude>, ...

The unit dB.

The following parameters are supported.

- TRACE1
Returns the magnitude of the measured weights of the reference signal (RS) carriers over one subframe.

9.6.1.15 CSI RS Weights Phase

For the CSI RS Weights Phase result display, the command returns one value for each subcarrier that has been analyzed.

<Phase>, ...

The unit degrees.

The following parameters are supported.

- TRACE1
Returns the phase of the measured weights of the reference signal (RS) carriers over one subframe.

9.6.1.16 EVM vs Carrier

For the EVM vs Carrier result display, the command returns one value for each subcarrier that has been analyzed.

<EVM>, ...

The unit depends on [UNIT:EVM](#).

The following parameters are supported.

- TRACE1
Returns the average EVM over all subframes
- TRACE2
Returns the minimum EVM found over all subframes. If you are analyzing a particular subframe, it returns nothing.
- TRACE3
Returns the maximum EVM found over all subframes. If you are analyzing a particular subframe, it returns nothing.

9.6.1.17 EVM vs RB

For the EVM vs RB result display, the command returns one value for each resource block that has been analyzed.

<EVM>, ...

The unit depends on [UNIT:EVM](#).

The following parameters are supported.

- TRACE1
Returns the average power for each resource block over all subframes.
- TRACE2
Returns the minimum power found over all subframes. If you are analyzing a particular subframe, it returns nothing.
- TRACE3
Returns the maximum power found over all subframes. If you are analyzing a particular subframe, it returns nothing.

9.6.1.18 EVM vs Subframe

For the EVM vs Subframe result display, the command returns one value for each subframe that has been analyzed.

<EVM>, ...

The unit depends on `UNIT:EVM`.

The following parameters are supported.

- TRACE1

9.6.1.19 EVM vs Symbol

For the EVM vs Symbol result display, the command returns one value for each OFDM symbol that has been analyzed.

<EVM>, ...

For measurements on a single subframe, the command returns the symbols of that subframe only.

The unit depends on `UNIT:EVM`.

The following parameters are supported.

- TRACE1

9.6.1.20 EVM vs Symbol x Carrier

For the EVM vs Symbol x Carrier, the command returns one value for each resource element.

<EVM[Symbol(0),Carrier(1)]>, ..., <EVM[Symbol(0),Carrier(n)]>,
 <EVM[Symbol(1),Carrier(1)]>, ..., <EVM[Symbol(1),Carrier(n)]>,
 ...

<EVM[Symbol(n),Carrier(1)]>, ..., <EVM[Symbol(n),Carrier(n)]>,

The unit depends on `UNIT:EVM`.

Resource elements that are unused return NAN.

The following parameters are supported.

- TRACE1

9.6.1.21 Frequency Error vs Symbol

For the Frequency Error vs Symbol result display, the command returns one value for each OFDM symbol that has been analyzed.

<frequency error>, ...

The unit is always Hz.

The following parameters are supported.

- TRACE1

9.6.1.22 On/Off Power

For the On/Off Power measurement, the number and type of return values depend on the parameter.

- TRACE1
Returns the power for the Off power regions.
`<absolute power>, ...`
The unit is always dBm.
- TRACE2
Returns the power for the transient regions.
`<absolute power>, ...`
The unit is always dBm.
- LIST
Returns the contents of the On/Off Power table. For each line, it returns seven values.
`<off period start limit>, <off period stop limit>, <time at delta to limit>, <absolute off power>, <distance to limit>, <falling transient period>, <rising transient period>, ...`
The unit for the `<absolute off power>` is dBm. The unit for the `<distance to limit>` is dB. All other values have the unit s.

9.6.1.23 Power Spectrum

For the Power Spectrum result display, the command returns one value for each trace point.

`<power>, ...`

The unit is always dBm/Hz.

The following parameters are supported.

- TRACE1

9.6.1.24 Power vs RB RS

For the Power vs RB RS result display, the command returns one value for each resource block of the reference signal that has been analyzed.

`<absolute power>, ...`

The unit is always dBm.

The following parameters are supported.

- TRACE1
Returns the average power over all subframes
- TRACE2

Returns the minimum power found over all subframes. If you are analyzing a particular subframe, it returns nothing.

- TRACE3
Returns the maximum power found over all subframes. If you are analyzing a particular subframe, it returns nothing.

9.6.1.25 Power vs RB PDSCH

For the Power vs RB PDSCH result display, the command returns one value for each resource block of the PDSCH that has been analyzed.

`<absolute power>, ...`

The unit is always dBm.

The following parameters are supported.

- TRACE1
Returns the average power over all subframes
- TRACE2
Returns the minimum power found over all subframes. If you are analyzing a particular subframe, it returns nothing.
- TRACE3
Returns the maximum power found over all subframes. If you are analyzing a particular subframe, it returns nothing.

9.6.1.26 Power vs Symbol x Carrier

For the Power vs Symbol x Carrier, the command returns one value for each resource element.

```
<P[Symbol(0),Carrier(1)]>, ..., <P[Symbol(0),Carrier(n)]>,
<P[Symbol(1),Carrier(1)]>, ..., <P[Symbol(1),Carrier(n)]>,
...
<P[Symbol(n),Carrier(1)]>, ..., <P[Symbol(n),Carrier(n)]>
```

with P = Power of a resource element.

The unit is always dBm.

Resource elements that are unused return NAN.

The following parameters are supported.

- TRACE1

9.6.1.27 Spectrum Emission Mask

For the SEM measurement, the number and type of returns values depend on the parameter.

- TRACE1

Returns one value for each trace point.

<absolute power>, ...

The unit is always dBm.

- LIST

Returns the contents of the SEM table. For every frequency in the spectrum emission mask, it returns nine values.

<index>, <start frequency in Hz>, <stop frequency in Hz>, <RBW in Hz>, <limit fail frequency in Hz>, <absolute power in dBm>, <relative power in dBc>, <limit distance in dB>, <limit check result>, ...

The <limit check result> is either a 0 (for PASS) or a 1 (for FAIL).

9.6.1.28 UE RS Weights Magnitude (Difference)

For the UE RS Weights Magnitude and UE RS Weights Magnitude Difference result display, the command returns one value for each subcarrier that has been analyzed.

<Magnitude>, ...

The unit dB.

The following parameters are supported.

- TRACE1

Returns the magnitude of the measured weights of the reference signal (RS) carriers over one subframe.

9.6.1.29 UE RS Weights Phase (Difference)

For the UE RS Weights Phase and UE RS Weights Phase Difference result display, the command returns one value for each subcarrier that has been analyzed.

<Phase>, ...

The unit degrees.

The following parameters are supported.

- TRACE1

Returns the phase of the measured weights of the reference signal (RS) carriers over one subframe.

9.6.1.30 Return Value Codes

This chapter contains a list for encoded return values.

<ACK/NACK>

The range is {-1...1}.

- 1 = ACK
- 0 = NACK
- -1 = DTX

<allocation ID>

Represents the allocation ID. The range is as follows.

- **0 - 65535** = PDSCH
- **-1** = Invalid / not used
- **-2** = All
- **-3** = P-SYNC
- **-4** = S-SYNC
- **-5** = Reference Signal (Antenna 1)
- **-6** = Reference Signal (Antenna 2)
- **-7** = Reference Signal (Antenna 3)
- **-8** = Reference Signal (Antenna 4)
- **-9** = PCFICH
- **-10** = PHICH
- **-11** = PDCCH
- **-12** = PBCH
- **-13** = PMCH
- **-14** = Positioning Reference Signal
- **-15** = CSI Reference Signal (Port 15 and 16)
- **-16** = CSI Reference Signal (Port 17 and 18)
- **-17** = CSI Reference Signal (Port 19 and 20)
- **-18** = CSI Reference Signal (Port 21 and 22)
- **-19** = EPDCCH
- **-20** = EPDCCH DMRS1
- **-21** = EPDCCH DMRS2
- **-22** = PMCH Reference Signal
- **-1xxxxx** = UE Reference Signal (Port 5)
- **-2xxxxx** = UE Reference Signal 1 (Port 7, 8, 11, 12)
- **-3xxxxx** = UE Reference Signal 2 (Port 9, 10, 13, 14, signals with more than 2 layers)

Note. **xxxxx** is a placeholder for the ID of the PDSCH.

If the PDSCH has, for example, the ID 22, the return value would be -100022, -200022 or -300022 (depending on the configuration)

<codeword>

Represents the codeword of an allocation. The range is {0...6}.

- **0** = 1/1
- **1** = 1/2
- **2** = 2/2
- **3** = 1/4
- **4** = 2/4
- **5** = 3/4

- **6** = 4/4

<DCI format>

Represents the DCI format. The value is a number in the range {0...103}.

- **0** = DCI format 0
- **10** = DCI format 1
- **11** = DCI format 1A
- **12** = DCI format 1B
- **13** = DCI format 1C
- **14** = DCI format 1D
- **20** = DCI format 2
- **21** = DCI format 2A
- **22** = DCI format 2B
- **23** = DCI format 2C
- **24** = DCI format 2D
- **30** = DCI format 3
- **31** = DCI format A
- **103** = DCI format 0/3/3A

<modulation>

Represents the modulation scheme. The range is {0...14}.

- **0** = unrecognized
- **1** = RBPSK
- **2** = QPSK
- **3** = 16QAM
- **4** = 64QAM
- **5** = 8PSK
- **6** = PSK
- **7** = mixed modulation
- **8** = BPSK
- **14** = 256QAM

<number of symbols or bits>

In hexadecimal mode, this represents the number of symbols to be transmitted. In binary mode, it represents the number of bits to be transmitted.

<PHICH duration>

Represents the PHICH duration. The range is {1...2}.

- **1** = normal
- **2** = extended

<PHICH resource>

Represents the parameter N_g . The range is {1...4}.

- 1 = N_g 1/6
- 2 = N_g 1/2
- 3 = N_g 1
- 4 = N_g 2

TRACe[:DATA]? <Result>

This command returns the trace data for the current measurement or result display.

For more information see [chapter 9.6.1, "Using the TRACe\[:DATA\] Command"](#), on page 158.

Query parameters:

TRACE1 | TRACE2 |
TRACE3

LIST

PBCH

PCFICH

PHICH

PDCCH

PDSCH

Usage: Query only

9.6.2 Reading Out Limit Check Results

- [Checking Limits for Graphical Result Displays](#)..... 173
- [Checking Limits for Numerical Result Display](#)..... 176

9.6.2.1 Checking Limits for Graphical Result Displays

CALCulate<n>:LIMit<k>:ACPower:ACHannel:RESult?	173
CALCulate<n>:LIMit<k>:ACPower:ALternate:RESult?	174
CALCulate<n>:MARKer<m>:FUNctIon:POWer:RESult[:CURRent]?.....	175
CALCulate<n>:LIMit<k>:OOPower:OFFPower?	175
CALCulate<n>:LIMit<k>:OOPower:TRANsient?	176

CALCulate<n>:LIMit<k>:ACPower:ACHannel:RESult? <Result>

This command queries the limit check results for the adjacent channels during ACLR measurements.

Query parameters:

<Result>

ALL

Queries the overall limit check results.

REL

Queries the channel power limit check results.

ABS

Queries the distance to the limit line.

Return values:

<LimitCheck>

Returns two values, one for the upper and one for the lower adjacent channel.

PASSED

Limit check has passed.

FAILED

Limit check has failed.

Example:`CALC:LIM:ACP:ACH:RES? ALL`

Queries the results of the adjacent channel limit check.

Usage:

Query only

CALCulate<n>:LIMit<k>:ACP:ALternate:RESult? <Result>

This command queries the limit check results for the alternate channels during ACLR measurements.

Query parameters:

<Result>

ALL

Queries the overall limit check results.

REL

Queries the channel power limit check results.

ABS

Queries the distance to the limit line.

Return values:

<LimitCheck>

Returns two values, one for the upper and one for the lower alternate channel.

PASSED

Limit check has passed.

FAILED

Limit check has failed.

Example:`CALC:LIM:ACP:ALT:RES? ALL`

Queries the results of the alternate channel limit check.

Usage:

Query only

CALCulate<n>:MARKer<m>:FUNction:POWer:RESult[:CURRent]? <ResultType>

This command queries the current results of the ACLR measurement or the total signal power level of the SEM measurement.

To get a valid result, you have to perform a complete measurement with synchronization to the end of the measurement before reading out the result. This is only possible for single sweeps.

Suffix:

<m> 1

Query parameters:

<ResultType>

CPOW

This parameter queries the signal power of the SEM measurement.

Return values:

<Result>

SEMResults

Power level in dBm.

ACLRResults

Relative power levels of the ACLR channels. The number of return values depends on the number of transmission and adjacent channels. The order of return values is:

- <TXChannelPower> is the power of the transmission channel in dBm
- <LowerAdjChannelPower> is the relative power of the lower adjacent channel in dB
- <UpperAdjChannelPower> is the relative power of the upper adjacent channel in dB
- <1stLowerAltChannelPower> is the relative power of the first lower alternate channel in dB
- <1stUpperAltChannelPower> is the relative power of the first upper alternate channel in dB
- (...)
- <nthLowerAltChannelPower> is the relative power of a subsequent lower alternate channel in dB
- <nthUpperAltChannelPower> is the relative power of a subsequent upper alternate channel in dB

Example:

CALC1:MARK:FUNC:POW:RES?

Returns the current ACLR measurement results.

Usage:

Query only

CALCulate<n>:LIMit<k>:OOPower:OFFPower?

This command queries the results of the limit check in the "Off" periods of On/Off Power measurements.

Return values:

<OOPResults> Returns one value for every "Off" period.

PASSED

Limit check has passed.

FAILED

Limit check has failed.

Example:

`CALC:LIM:OOP:OFFP?`

Queries the results for the limit check during the signal Off periods.

Usage:

Query only

CALCulate<n>:LIMit<k>:OOPower:TRANsient? <Result>

This command queries the results of the limit check during the transient periods of the On/Off power measurement.

Query parameters:

<Result>

ALL

Queries the overall limit check results.

FALLing

Queries the limit check results of falling transients.

RISing

Queries the limit check results of rising transients.

Return values:

<OOPResults> Returns one value for every "Off" period.

PASSED

Limit check has passed.

FAILED

Limit check has failed.

Example:

`CALC:LIM:OOP:TRAN? RIS`

Queries the limit check of rising transients.

Usage:

Query only

9.6.2.2 Checking Limits for Numerical Result Display

<code>CALCulate<n>:LIMit<k>:SUMMary:EVM[:ALL]:MAXimum:RESult?</code>	177
<code>CALCulate<n>:LIMit<k>:SUMMary:EVM[:ALL]:AVERage]:RESult?</code>	177
<code>CALCulate<n>:LIMit<k>:SUMMary:EVM:DSQP:MAXimum:RESult?</code>	177
<code>CALCulate<n>:LIMit<k>:SUMMary:EVM:DSQP[:AVERage]:RESult?</code>	177
<code>CALCulate<n>:LIMit<k>:SUMMary:EVM:DSSF:MAXimum:RESult?</code>	178
<code>CALCulate<n>:LIMit<k>:SUMMary:EVM:DSSF[:AVERage]:RESult?</code>	178
<code>CALCulate<n>:LIMit<k>:SUMMary:EVM:DSST:MAXimum:RESult?</code>	178
<code>CALCulate<n>:LIMit<k>:SUMMary:EVM:DSST[:AVERage]:RESult?</code>	178
<code>CALCulate<n>:LIMit<k>:SUMMary:EVM:PCHannel:MAXimum:RESult?</code>	178
<code>CALCulate<n>:LIMit<k>:SUMMary:EVM:PCHannel[:AVERage]:RESult?</code>	178

CALCulate<n>:LIMit<k>:SUMMary:EVM:PSIGnal:MAXimum:RESult?	179
CALCulate<n>:LIMit<k>:SUMMary:EVM:PSIGnal[:AVERage]:RESult?	179
CALCulate<n>:LIMit<k>:SUMMary:FERRor:MAXimum:RESult?	179
CALCulate<n>:LIMit<k>:SUMMary:FERRor[:AVERage]:RESult?	179
CALCulate<n>:LIMit<k>:SUMMary:GIMBalance:MAXimum:RESult?	180
CALCulate<n>:LIMit<k>:SUMMary:GIMBalance[:AVERage]:RESult?	180
CALCulate<n>:LIMit<k>:SUMMary:IQOffset:MAXimum:RESult?	180
CALCulate<n>:LIMit<k>:SUMMary:IQOffset[:AVERage]:RESult?	180
CALCulate<n>:LIMit<k>:SUMMary:QUADerror:MAXimum:RESult?	180
CALCulate<n>:LIMit<k>:SUMMary:QUADerror[:AVERage]:RESult?	180
CALCulate<n>:LIMit<k>:SUMMary:SERRor:MAXimum:RESult?	181
CALCulate<n>:LIMit<k>:SUMMary:SERRor[:AVERage]:RESult?	181

CALCulate<n>:LIMit<k>:SUMMary:EVM[:ALL]:MAXimum:RESult?
CALCulate<n>:LIMit<k>:SUMMary:EVM[:ALL][:AVERage]:RESult?

This command queries the results of the EVM limit check of all resource elements.

Return values:

<LimitCheck> The type of limit (average or maximum) that is queried depends on the last syntax element.

FAILED

Limit check has failed.

PASSED

Limit check has passed.

NOTEVALUATED

Limits have not been evaluated.

Example:

```
CALC:LIM:SUMM:EVM:RES?
```

Queries the limit check.

Usage:

Query only

CALCulate<n>:LIMit<k>:SUMMary:EVM:DSQP:MAXimum:RESult?
CALCulate<n>:LIMit<k>:SUMMary:EVM:DSQP[:AVERage]:RESult?

This command queries the results of the EVM limit check of all PDSCH resource elements with a QPSK modulation.

Return values:

<LimitCheck> The type of limit (average or maximum) that is queried depends on the last syntax element.

FAILED

Limit check has failed.

PASSED

Limit check has passed.

NOTEVALUATED

Limits have not been evaluated.

Example:

```
CALC:LIM:SUMM:EVM:DSQP:RES?
```

Queries the limit check.

Usage: Query only

CALCulate<n>:LIMit<k>:SUMMary:EVM:DSSF:MAXimum:RESult?
CALCulate<n>:LIMit<k>:SUMMary:EVM:DSSF[:AVERage]:RESult?

This command queries the results of the EVM limit check of all PDSCH resource elements with a 64QAM modulation.

Return values:

<LimitCheck> The type of limit (average or maximum) that is queried depends on the last syntax element.

FAILED

Limit check has failed.

PASSED

Limit check has passed.

NOTEVALUATED

Limits have not been evaluated.

Example: `CALC:LIM:SUMM:EVM:DSSF:RES?`
 Queries the limit check.

Usage: Query only

CALCulate<n>:LIMit<k>:SUMMary:EVM:DSST:MAXimum:RESult?
CALCulate<n>:LIMit<k>:SUMMary:EVM:DSST[:AVERage]:RESult?

This command queries the results of the EVM limit check of all PDSCH resource elements with a 16QAM modulation.

Return values:

<LimitCheck> The type of limit (average or maximum) that is queried depends on the last syntax element.

FAILED

Limit check has failed.

PASSED

Limit check has passed.

NOTEVALUATED

Limits have not been evaluated.

Example: `CALC:LIM:SUMM:EVM:DSST:RES?`
 Queries the limit check.

Usage: Query only

CALCulate<n>:LIMit<k>:SUMMary:EVM:PCHannel:MAXimum:RESult?
CALCulate<n>:LIMit<k>:SUMMary:EVM:PCHannel[:AVERage]:RESult?

This command queries the results of the EVM limit check of all physical channel resource elements.

Return values:

<LimitCheck>

The type of limit (average or maximum) that is queried depends on the last syntax element.

FAILED

Limit check has failed.

PASSED

Limit check has passed.

NOTEVALUATED

Limits have not been evaluated.

Example:

```
CALC:LIM:SUMM:EVM:PCH:RES?
```

Queries the limit check.

Usage:

Query only

CALCulate<n>:LIMit<k>:SUMMary:EVM:PSIGnal:MAXimum:RESult?

CALCulate<n>:LIMit<k>:SUMMary:EVM:PSIGnal[:AVERage]:RESult?

This command queries the results of the EVM limit check of all physical signal resource elements.

Return values:

<LimitCheck>

The type of limit (average or maximum) that is queried depends on the last syntax element.

FAILED

Limit check has failed.

PASSED

Limit check has passed.

NOTEVALUATED

Limits have not been evaluated.

Example:

```
CALC:LIM:SUMM:EVM:PSIG:RES?
```

Queries the limit check.

Usage:

Query only

CALCulate<n>:LIMit<k>:SUMMary:FERRor:MAXimum:RESult?

CALCulate<n>:LIMit<k>:SUMMary:FERRor[:AVERage]:RESult?

This command queries the result of the frequency error limit check.

Return values:

<LimitCheck>

The type of limit (average or maximum) that is queried depends on the last syntax element.

FAILED

Limit check has failed.

PASSED

Limit check has passed.

NOTEVALUATED

Limits have not been evaluated.

Example: `CALC:LIM:SUMM:SERR:RES?`
Queries the limit check.

Usage: Query only

CALCulate<n>:LIMit<k>:SUMMary:GIMBalance:MAXimum:RESult?
CALCulate<n>:LIMit<k>:SUMMary:GIMBalance[:AVERage]:RESult?

This command queries the result of the gain imbalance limit check.

Return values:

<LimitCheck> The type of limit (average or maximum) that is queried depends on the last syntax element.

FAILED

Limit check has failed.

PASSED

Limit check has passed.

NOTEVALUATED

Limits have not been evaluated.

Example: `CALC:LIM:SUMM:GIMB:RES?`
Queries the limit check.

Usage: Query only

CALCulate<n>:LIMit<k>:SUMMary:IQOFfset:MAXimum:RESult?
CALCulate<n>:LIMit<k>:SUMMary:IQOFfset[:AVERage]:RESult?

This command queries the result of the I/Q offset limit check.

Return values:

<LimitCheck> The type of limit (average or maximum) that is queried depends on the last syntax element.

FAILED

Limit check has failed.

PASSED

Limit check has passed.

NOTEVALUATED

Limits have not been evaluated.

Example: `CALC:LIM:SUMM:IQOF:MAX:RES?`
Queries the limit check.

Usage: Query only

CALCulate<n>:LIMit<k>:SUMMary:QUADerror:MAXimum:RESult?
CALCulate<n>:LIMit<k>:SUMMary:QUADerror[:AVERage]:RESult?

This command queries the result of the quadrature error limit check.

Return values:

<LimitCheck> The type of limit (average or maximum) that is queried depends on the last syntax element.

FAILED

Limit check has failed.

PASSED

Limit check has passed.

NOTEVALUATED

Limits have not been evaluated.

Example:

CALC:LIM:SUMM:QUAD:RES?

Queries the limit check.

Usage:

Query only

CALCulate<n>:LIMit<k>:SUMMary:SERRor:MAXimum:RESult?

CALCulate<n>:LIMit<k>:SUMMary:SERRor[:AVERage]:RESult?

This command queries the results of the sampling error limit check.

Return values:

<LimitCheck> The type of limit (average or maximum) that is queried depends on the last syntax element.

FAILED

Limit check has failed.

PASSED

Limit check has passed.

NOTEVALUATED

Limits have not been evaluated.

Example:

CALC:LIM:SUMM:SERR:RES?

Queries the limit check.

Usage:

Query only

9.7 Remote Commands to Configure General Settings

- [Remote Commands for General Settings](#)..... 181
- [Configuring MIMO Measurement Setups](#)..... 190
- [Using a Trigger](#)..... 192
- [Configuring Spectrum Measurements](#)..... 194
- [Remote Commands for Advanced Settings](#)..... 196

9.7.1 Remote Commands for General Settings

This chapter contains remote control commands necessary to control the general measurement settings.

For more information see [chapter 4.1, "Configuring the Measurement"](#), on page 68.

- [Defining General Signal Characteristics](#)..... 182
- [Selecting the Input Source](#)..... 183
- [Configuring the Input Level](#)..... 183
- [Configuring the Data Capture](#)..... 185
- [Configuring Measurement Results](#)..... 186
- [Configuring Time Alignment Measurements](#)..... 188
- [Configuring On/Off Power Measurements](#)..... 189

9.7.1.1 Defining General Signal Characteristics

CONFigure[:LTE]:DUPLexing	182
CONFigure[:LTE]:LDIRection	182
[SENSe]:FREQuency:CENTer[:CC<cci>]	182

CONFigure[:LTE]:DUPLexing <Duplexing>

This command selects the duplexing mode.

Parameters:

<Duplexing>	TDD Time division duplex
	FDD Frequency division duplex
	*RST: FDD

Example:

```
CONF:DUPL TDD
Activates time division duplex.
```

CONFigure[:LTE]:LDIRection <Direction>

This command selects the link direction

Parameters:

<Direction>	DL Downlink
	UL Uplink

Example:

```
CONF:LDIR DL
EUTRA/LTE option is configured to analyze downlink signals.
```

[SENSe]:FREQuency:CENTer[:CC<cci>] <Frequency>

This command sets the center frequency for RF measurements.

Parameters:

<Frequency> <numeric value>
 Range: fmin to fmax
 *RST: 1 GHz
 Default unit: Hz

Example:

Measurement on one carrier:
`FREQ:CENT 1GHZ`
 Defines a center frequency of 1 GHz

Example:

Measurement on aggregated carriers:
`FREQ:CENT:CC1 850MHZ`
 Defines a center frequency of 850 MHz for the first carrier.

9.7.1.2 Selecting the Input Source

`SENSe:INPut`..... 183

SENSe:INPut <Source>

This command selects the signal source.

Parameters:

<Source> **RF**
 Select radio frequency input as signal source.
 AIQ
 Select analog I/Q input (baseband) as signal source.
 DIQ
 Select digital I/Q input as signal source.

Example:

`INP DIQ`
 Select digital I/Q as signal source.

9.7.1.3 Configuring the Input Level

`[SENSe]:POWer:AUTO<instrument>[:STATe]`..... 183
`CONFigure:POWer:EXPeCted:RF<instrument>`..... 184
`CONFigure:POWer:EXPeCted:IQ<instrument>`..... 184
`INPut<n>:ATTenuation<instrument>`..... 184
`DISPlay[:WINDow<n>]:TRACe<t>:Y[:SCALe]:RLEVel:OFFSet`..... 185

[SENSe]:POWer:AUTO<instrument>[:STATe] <State>

This command initiates a measurement that determines the ideal reference level.

Parameters:

<State>

OFF

Performs no automatic reference level detection.

ON

Performs an automatic reference level detection before each measurement.

ONCE

Performs an automatic reference level once.

***RST:** ON**Example:**`POW:AUTO2 ON`

Activate auto level for analyzer number 2.

CONFigure:POWer:EXPected:RF<instrument> <RefLevel>

This command defines the reference level when the input source is RF.

Parameters:

<RefLevel>

***RST:** -30 dBm

Default unit: DBM

Example:`CONF:POW:EXP:RF3 -20`

Sets the radio frequency reference level used by analyzer 3 to -20 dBm.

CONFigure:POWer:EXPected:IQ<instrument> <RefLevel>

This command defines the reference level when the input source is baseband.

Parameters:

<RefLevel>

<numeric value>

Range: 31.6 mV to 5.62 V

***RST:** 1 V

Default unit: V

Example:`CONF:POW:EXP:IQ2 3.61`

Sets the baseband-reference level used by analyzer 2 to 3.61 V.

INPut<n>:ATTenuation<instrument> <Attenuation>

This command sets the RF attenuation level.

Parameters:

<Attenuation>

<numeric value>

***RST:** 5 dB

Default unit: dB

Example:`INP:ATT 10`

Defines an RF attenuation of 10 dB.

DISPlay[:WINDow<n>]:TRACe<t>:Y[:SCALe]:RLEVel:OFFSet <Attenuation>

This command selects the external attenuation or gain applied to the RF signal.

Parameters:

<Attenuation> <numeric value>
 *RST: 0
 Default unit: dB

Example:

DISP:TRAC:Y:RLEV:OFFS 10
 Sets an external attenuation of 10 dB.

9.7.1.4 Configuring the Data Capture

[SENSe]:SWEep:TIME.....	185
[SENSe][:LTE]:FRAMe:COUNT:STATe.....	185
[SENSe][:LTE]:FRAMe:COUNT.....	185
[SENSe][:LTE]:FRAMe:COUNT:AUTO.....	186
[SENSe][:LTE]:FRAMe:SCOunt.....	186

[SENSe]:SWEep:TIME <CaptLength>

This command sets the capture time.

Parameters:

<CaptLength> Numeric value in seconds.
 Default unit: s

Example:

SWE:TIME 40ms
 Defines a capture time of 40 milliseconds.

[SENSe][:LTE]:FRAMe:COUNT:STATe <State>

This command turns manual selection of the number of frames you want to analyze on and off.

Parameters:

<State> **ON**
 You can set the number of frames to analyze.
 OFF
 The software analyzes a single sweep.
 *RST: ON

Example:

FRAM:COUN:STAT ON
 Turns manual setting of number of frames to analyze on.

[SENSe][:LTE]:FRAMe:COUNT <Subframes>

This command sets the number of frames you want to analyze.

Parameters:

<Subframes> <numeric value>
 *RST: 1

Example:

```
FRAM:COUN:STAT ON
FRAM:COUN:AUTO OFF
Activates manual input of frames to be analyzed.
FRAM:COUN 20
Analyzes 20 frames.
```

[SENSe][:LTE]:FRAMe:COUNt:AUTO <State>

This command turns automatic selection of the number of frames to analyze on and off.

Parameters:

<State> **ON**
 Selects the number of frames to analyze according to the LTE standard.

OFF
 Turns manual selection of the frame number on.

Example:

```
FRAM:COUN:AUTO ON
Turns automatic selection of the analyzed frames on.
```

[SENSe][:LTE]:FRAMe:SCOunt <Subframes>

This command selects the maximum number of subframes to analyze.

Selecting a number of subframes different from the default one may become necessary if the capture time is less than 20.1 ms.

Parameters:

<Subframes> **ALL**
 Analyzes all subframes of a frame (10).

 <numeric value>
 Number of subframes that the software analyzes.

Range: 1 to 9
 *RST: ALL

Example:

```
FRAM:SCO 3
Analyzes three subframes.
```

9.7.1.5 Configuring Measurement Results

UNIT:EVM.....	187
UNIT:BSTR.....	187
UNIT:CAXes.....	187

[SENSe][:LTE]:ANTenna:SElect.....	187
[SENSe][:LTE]:SOURce:SElect.....	188
[SENSe][:LTE]:SUBFrame:SElect.....	188

UNIT:EVM <Unit>

This command selects the EVM unit.

Parameters:

<Unit>	DB EVM results returned in dB
	PCT EVM results returned in %
*RST:	PCT

Example: UNIT:EVM PCT
EVM results to be returned in %.

UNIT:BSTR <Unit>

This command selects the way the bit stream is displayed.

Parameters:

<Unit>	SYMBOLs Displays the bit stream using symbols
	BITs Displays the bit stream using bits
*RST:	SYMBOLs

Example: UNIT:BSTR BIT
Bit stream gets displayed using Bits.

UNIT:CAXes <Unit>

This command selects the scale of the x-axis for result displays that show subcarrier results.

Parameters:

<Unit>	CARR Shows the number of the subcarriers on the x-axis.
	HZ Shows the frequency of the subcarriers on the x-axis.

Example: UNIT:CAX HZ
Selects frequency scale for the x-axis.

[SENSe][:LTE]:ANTenna:SElect <Antenna>

This command selects the antenna for which the results are shown.

Available if the number of input channels is "From Antenna Selection".

Parameters:

<Antenna> Number of the antenna.
1 | 2 | 3 | 4
 Number of the antenna.
ALL
 Shows the results for all antennas.
 *RST: 1

Example:

SENS:ANT:SEL 2
 Selects antenna 2.

[SENSe][:LTE]:SOURce:SElect <Source>

This command selects the antenna (ports) the results are displayed for.

Parameters:

<Source> **ALL**
 Shows the results for all I/Q data streams in the result display.
<numeric value>
 Selects one I/Q data stream to display the results for. The range depends on the number of input channels you are using.

Example:

SOUR:SEL 4
 Shows the results for the 4th I/Q data stream.

[SENSe][:LTE]:SUBFrame:SElect <Subframe>

This command selects the subframe to be analyzed.

Parameters:

<Subframe> ALL | <numeric value>
ALL
 Select all subframes
0...39
 Select a single subframe
 *RST: ALL

Example:

SUBF:SEL ALL
 Select all subframes for analysis.

9.7.1.6 Configuring Time Alignment Measurements

Remote commands to configure Time Alignment measurements described elsewhere:

- [SENSe]:FREQuency:CENTer[:CC<cci>] on page 182
 Demod settings for CC2: [chapter 9.8, "Remote Command to Configure the Demodulation"](#), on page 199

CONFigure:NOCC..... 189

CONFigure:NOCC <Carriers>

This command selects the number of component carriers evaluated in the Time Alignment measurement.

Parameters:

<Carriers> 1 | 2
*RST: 1

Example: CONF:NOCC 2
 Selects 2 carriers.

9.7.1.7 Configuring On/Off Power Measurements

[SENSe][:LTE]:OOPower:CAGGregation.....	189
[SENSe][:LTE]:OOPower:FREQUENCY:HIGHer.....	189
[SENSe][:LTE]:OOPower:FREQUENCY:LOWer.....	190
[SENSe][:LTE]:OOPower:NCORrection.....	190
CONFigure[:LTE]:OOPower:NFRames.....	190

[SENSe][:LTE]:OOPower:CAGGregation <NoiseCorrection>

This command turns carrier aggregation for Transmit On/Off Power measurements on and off.

Parameters:

<NoiseCorrection> ON | OFF
*RST: OFF

Example: FREQ:CENT 1GHZ
 Defines a center for the master component carrier of 1 GHz.
 OOP:CAGG ON
 OOP:FREQ:LOW 950MHZ
 OOP:FREQ:HIGH 1050MHZ
 Turns on carrier aggregation and defines a frequency band
 between 950 MHz and 1.05 GHz.

[SENSe][:LTE]:OOPower:FREQUENCY:HIGHer <Frequency>

This command defines the higher edge frequency for Transmit On/Off Power measurements with carrier aggregation.

Parameters:

<Frequency> <numeric value>
 Default unit: Hz

Example: See [SENSe][:LTE]:OOPower:CAGGregation.

[SENSe][:LTE]:OOPower:FREQUENCY:LOWer <Frequency>

This command defines the lower edge frequency for Transmit On/Off Power measurements with carrier aggregation.

Parameters:

<Frequency> <numeric value>

Default unit: Hz

Example: See `[SENSe][:LTE]:OOPower:CAGgregation`.

[SENSe][:LTE]:OOPower:NCORrection <NoiseCorrection>

This command turns noise correction for On/Off Power measurements on and off.

Parameters:

<NoiseCorrection> ON | OFF

CONFigure[:LTE]:OOPower:NFRames <Frames>

This command defines the number of frames that are analyzed for On/Off Power measurements.

Parameters:

<Frames> <numeric value>

Example: `CONF:OOP:NFR 10`
Defines 10 frames to be analyzed.

9.7.2 Configuring MIMO Measurement Setups

Commands useful to configure MIMO setups described elsewhere:

- `CONFigure[:LTE]:DL[:CC<cci>]:MIMO:ASElection` on page 208
- `CONFigure[:LTE]:DL[:CC<cci>]:MIMO:CONFig` on page 208

<code>CONFigure:ACONfig<instrument>:ADDRESS</code>	190
<code>CONFigure:ACONfig<instrument>:ICSequence</code>	191
<code>CONFigure:ACONfig<instrument>:NChannels</code>	191
<code>CONFigure[:LTE]:NSources</code>	191

CONFigure:ACONfig<instrument>:ADDRESS <Address>

This command defines the network address of an analyzer or oscilloscope in the test setup.

Parameters:

<Address> String containing the address of the analyzer.
Connections are possible via TCP/IP or GPIB. Depending on the type of connection, the string has the following syntax.
'GPIB[board]::<PrimaryAddress>[:<SecondaryAddress>][:INSTR]'
'TCPIP[board]::<HostAddress>[:<LANDeviceName>][:INSTR]'
Elements in square brackets are optional.

Example:

```
CONF:ACON:ADDR 'TCPIP::192.168.0.1'
```

Defines a TCP/IP connection for the first analyzer in the test setup.

```
CONF:ACON:ADDR 'GPIB::28'
```

Defines a GPIB connection for the first analyzer in the test setup.

CONFigure:ACONfig<instrument>:ICSequence <ICSequence>

This command defines the sequence in which the oscilloscope channels are accessed.

Parameters:

<ICSequence> String containing a sequence of four numbers between 1 and 4. Each number represents an input channel.

Example:

```
CONF:ACON:ICS '1,3,2,4'
```

Defines the sequence for an oscilloscope with four channels. The channels are subsequently accessed in the order 1 → 3 → 2 → 4.

CONFigure:ACONfig<instrument>:NCHannels <NCHannels>

This command defines the number of oscilloscope channels you want to use.

Parameters:

<NCHannels> 1 | 2 | 3 | 4
The maximum number you can select depends on the number of channels of the oscilloscope you are using.

Example:

```
CONF:ACON:NCH 2
```

Defines a measurement on 2 channels.

CONFigure[:LTE]:NSources <Channels>

This command selects the number of input channels you are using to capture several streams of I/Q data.

Parameters:<Channels> **1 | 2 | 4 | 8****ASEL**

Number of channels is the same as the number of Tx antennas in the test setup (`CONFigure[:LTe]:DL[:CC<cci>]:MIMO:CONFig`).

Example:

```
CONF:NSO 4
Selects four input channels.
```

9.7.3 Using a Trigger

<code>TRIGger[:SEquence]:MODE</code>	192
<code>TRIGger[:SEquence]:HOLDoff<instrument></code>	192
<code>TRIGger[:SEquence]:LEVel<instrument>[:EXTeRnal]</code>	193
<code>TRIGger[:SEquence]:LEVel<instrument>:POWeR</code>	193
<code>TRIGger[:SEquence]:PORT<instrument></code>	193
<code>TRIGger[:SEquence]:SLOPe</code>	193

TRIGger[:SEquence]:MODE <Source>

This command selects the trigger source.

Parameters:

<Source>

EXTeRnal

Selects external trigger source.

IMMeDiate

Selects free run trigger source.

POWeR

Selects IF power trigger source.

TUNit

Selects the trigger unit R&S FS-Z11 as the trigger source.

```
*RST:      IMMeDiate
```

Example:

```
TRIG:MODE EXT
Selects an external trigger source.
```

TRIGger[:SEquence]:HOLDoff<instrument> <Offset>

This command defines the trigger offset.

Parameters:

<Offset>

<numeric value>

```
*RST:      0 s
```

Default unit: s

Example:

```
TRIG:HOLD 5MS
Sets the trigger offset to 5 ms.
```

TRIGger[:SEQuence]:LEVel<instrument>[:EXTeRnal] <Level>

This command defines the level for an external trigger.

Parameters:

<Level> Range: 0.5 V to 3.5 V
 *RST: 1.4 V
 Default unit: V

Example:

TRIG:LEV 2V
Defines a trigger level of 2 V.

TRIGger[:SEQuence]:LEVel<instrument>:POWeR <Level>

This command defines the trigger level for an IF power trigger.

Parameters:

<Level> Default unit: DBM

Example:

TRIG:LEV:POW 10
Defines a trigger level of 10 dBm.

TRIGger[:SEQuence]:PORT<instrument> <Port>

This command selects the trigger port for measurements with devices that have several trigger ports.

(The R&S FSW, for example has several trigger ports.)

Parameters:

<Port> **PORT1**
 PORT2
 PORT3

Example:

TRIG:PORT PORT1
Selects trigger port 1.

TRIGger[:SEQuence]:SLOPe <Slope>

This command selects the trigger slope.

Parameters:

<Slope> **POSitive**
 Triggers a measurement when the signal rises to the trigger level.
 NEGative
 Triggers a measurement when the signal falls to the trigger level.

Example:

TRIG:SLOP POS
Selects a positive trigger slope.

9.7.4 Configuring Spectrum Measurements

- [Configuring SEM and ACLR Measurements](#).....194

9.7.4.1 Configuring SEM and ACLR Measurements

[SENSe]:POWer:SEM:CATegory	194
[SENSe]:POWer:SEM:CHBS:AMPower:AUTO	194
[SENSe]:POWer:ACHannel:AACHannel	195
[SENSe]:POWer:NCORrection	195
[SENSe]:SWEp:EGATe:AUTO	195

[SENSe]:POWer:SEM:CATegory <Category>

This command selects the SEM limit category as defined in 3GPP TS 36.104.

Parameters:

<Category>	A Category A (Wide Area base station)
	B1 Category B Opt 1 (Wide Area base station)
	B2 Category B Opt 2 (Wide Area base station)
	HOME Home base station
	LARE Local Area base station
	MED Medium Range base station
	*RST: A

Example:

```
POW:SEM:CAT B
Selects SEM category B.
```

[SENSe]:POWer:SEM:CHBS:AMPower:AUTO <State>

This command turn automatic detection of the TX channel power on and off.

The command is available for measurements on Medium Range base stations. When you turn it off, you can define the TX channel power manually with [\[SENSe\]:POWer:SEM:CHBS:AMPower](#).

Parameters:

<State>	ON OFF
	*RST: OFF

Example:

```
POW:SEM:CHBS:AMP:AUTO ON
Turns on automatic detection of the TX channel power.
```

[SENSe]:POWer:ACHannel:AACHannel <Channel>

This command selects the assumed adjacent channel carrier for ACLR measurements.

Parameters:

<Channel>

EUTRA

Selects an EUTRA signal of the same bandwidth like the TX channel as assumed adjacent channel carrier.

UTRA128

Selects an UTRA signal with a bandwidth of 1.28MHz as assumed adjacent channel carrier.

UTRA384

Selects an UTRA signal with a bandwidth of 3.84MHz as assumed adjacent channel carrier.

UTRA768

Selects an UTRA signal with a bandwidth of 7.68MHz as assumed adjacent channel carrier.

*RST: EUTRA

Example:

POW:ACH:AACH UTRA384

Selects an UTRA signal with a bandwidth of 3.84MHz as assumed adjacent channel carrier.

[SENSe]:POWer:NCORrection <State>

This command turns noise correction for ACLR measurements on and off.

Parameters:

<State>

ON | OFF

*RST: OFF

Example:

POW:NCOR ON

Activates noise correction.

[SENSe]:SWEep:EGATe:AUTO <State>

This command turns auto gating for SEM and ACLR measurements on and off.

This command is available for TDD measurements in combination with an external or IF power trigger.

Parameters:

<State>

ON

Evaluates the on-period of the LTE signal only.

OFF

Evaluates the complete signal.

Example:

SWE:EGAT:AUTO ON

Turns auto gating on.

9.7.5 Remote Commands for Advanced Settings

This chapter contains all remote control commands to control the advanced settings.

For more information on advanced settings see [chapter 4.5, "Advanced Settings"](#), on page 84.

- [Controlling I/Q Data](#)..... 196
- [Configuring the Baseband Input](#)..... 196
- [Using Advanced Input Settings](#)..... 197
- [Configuring the Digital I/Q Input](#)..... 198
- [Configuring Home Base Stations](#)..... 198
- [Mapping Antenna Ports](#)..... 199

9.7.5.1 Controlling I/Q Data

[SENSe]:SWAPiq	196
INPut:IQ:FSOFFset	196

[SENSe]:SWAPiq <State>

This command turns a swap of the I and Q branches on and off.

Parameters:

<State> ON | OFF
 *RST: OFF

Example:

SWAP ON
 Turns a swap of the I and Q branches on.

INPut:IQ:FSOFFset <Offset>

This command defines the location in an I/Q data file where the analysis starts.

Parameters:

<Offset> Time offset relative to the start offset of the I/Q data.
 Default unit: S

Example:

INP:IQ:FSOF 0.2
 Defines an offset of 0.2 seconds.

9.7.5.2 Configuring the Baseband Input

INPut:IQ:IMPedance	196
INPut:IQ:BALanced[:STATe]	197
[SENSe]:IQ:LPASs[:STATe]	197
[SENSe]:IQ:DITHer[:STATe]	197

INPut:IQ:IMPedance <Impedance>

This command selects the input impedance for I/Q inputs.

Parameters:

<Impedance> LOW | HIGH
 *RST: LOW

Example:

INP:IQ:IMP LOW
 Selects low input impedance for I/Q input.

INPut:IQ:BALEnced[:STATe] <State>

This command selects if the I/Q inputs are symmetrical (balanced) or asymmetrical (unbalanced)

Parameters:

<State> ON | OFF
 *RST: ON

Example:

INP:IQ:BALE ON
 Specifies symmetrical (balanced) IQ inputs.

[SENSe]:IQ:LPASs[:STATe] <State>

This command turns a baseband input lowpass filter on and off.

Parameters:

<State> ON | OFF
 *RST: ON

Example:

IQ:LPAS ON
 Activate the input lowpass.

[SENSe]:IQ:DITHer[:STATe] <State>

This command adds or removes a noise signal into the signal path (dithering).

Parameters:

<State> ON | OFF
 *RST: OFF

Example:

IQ:DITH ON
 Activate input dithering.

9.7.5.3 Using Advanced Input Settings

[SENSe]:POWER:AUTO<instrument>:TIME..... 197

[SENSe]:POWER:AUTO<instrument>:TIME <Time>

This command defines the track time for the auto level process.

Parameters:

<Time> <numeric value>
 *RST: 100 ms
 Default unit: s

Example:

POW:AUTO:TIME 200ms
 An auto level track time of 200 ms gets set.

9.7.5.4 Configuring the Digital I/Q Input

The digital I/Q input is available with option R&S FSQ-B17 or R&S FSV-B17.

INPut<n>:DIQ:RANGe[:UPPer].....198
 INPut<n>:DIQ:SRATe.....198

INPut<n>:DIQ:RANGe[:UPPer] <ScaleLevel>

This command defines the full scale level for a digital I/Q signal source.

Parameters:

<ScaleLevel> *RST: 1 V
 Default unit: V

Example:

INP:DIQ:RANG 0.7
 Sets the full scale level to 0.7 V.

INPut<n>:DIQ:SRATe <SampleRate>

This command defines the sampling rate for a digital I/Q signal source.

Parameters:

<SampleRate> *RST: 10 MHz
 Default unit: Hz

Example:

INP:DIQ:SRAT 10MHZ
 Defines a sampling rate of 10 MHz.

9.7.5.5 Configuring Home Base Stations

[SENSe]:POWer:SEM:CHBS:AMPower.....198

[SENSe]:POWer:SEM:CHBS:AMPower <Power>

This command defines the aggregated maximum power for home base stations or the TX power for medium range base stations.

In case of medium range base stations, the command is available after [SENSe] : POWer:SEM:CHBS:AMPower:AUTO has been turned off.

Parameters:

<Power> Numeric value
 Default unit: dBm

Example: `POW:SEM:CHBS:AMP 0`
Defines a power of 0 dBm.

9.7.5.6 Mapping Antenna Ports

`CONFigure[:LTE]:DL[:CC<cci>]:MIMO:SUAP`..... 199

CONFigure[:LTE]:DL[:CC<cci>]:MIMO:SUAP <Antenna>

This command selects the antenna port that should be measured on the first input channel.

Parameters:

<Antenna>

AUTO

Automatically assigns the antenna port.

**AP715 | AP816 | AP917 | AP1018 | AP1119 | AP1220 |
AP1321 | AP1422**

Assigns a specific antenna port to input channel 1.

Example:

`CONF:DL:MIMO:SUAP AP715`

Antenna port 7/15 is measured on input channel 1.

9.8 Remote Command to Configure the Demodulation



Configuring component carriers

If you want to configure the second component carrier (CC2), make sure to include the **[:CC2]** part of the syntax.

Example: `CONF:DL:CC2:BW 10`

- [Remote Commands for PDSCH Demodulation Settings](#)..... 199
- [Remote Commands for DL Signal Characteristics](#).....204
- [Remote Commands for DL Advanced Signal Characteristics](#).....213
- [Remote Commands for MBSFN Settings](#)..... 223

9.8.1 Remote Commands for PDSCH Demodulation Settings

This chapter contains remote commands necessary to define PDSCH demodulation.

For more information see [chapter 5.1, "Configuring Downlink Signal Demodulation"](#), on page 89.

- [Selecting the Demodulation Method](#).....200
- [Configuring Multicarrier Base Stations](#).....200
- [Configuring Parameter Estimation](#)..... 201
- [Compensating Measurement Errors](#)..... 201

- [Configuring EVM Measurements](#)..... 202
- [Processing Demodulated Data](#)..... 203
- [Configuring MIMO Setups](#)..... 203

9.8.1.1 Selecting the Demodulation Method

[SENSe][:LTE]:DL:DEMod:AUTO	200
[SENSe][:LTE]:DL:FORMat:PSCD	200

[SENSe][:LTE]:DL:DEMod:AUTO <State>

This command turns automatic demodulation for downlink signals on and off.

Parameters:

<State> ON | OFF
 *RST: ON

Example:

DL:DEM:AUTO ON
 Activates the auto-demodulation for DL.

[SENSe][:LTE]:DL:FORMat:PSCD <Format>

This command selects the method of identifying the PDSCH resource allocation.

Parameters:

<Format> **OFF**
 Applies the user configuration of the PDSCH subframe regardless of the signal characteristics.

PDCCH
 Identifies the configuration according to the data in the PDCCH DCIs.

PHYDET
 Manual PDSCH configuration: analysis only if the actual subframe configuration matches the configured one.
 Automatic PDSCH configuration: physical detection of the configuration.

 *RST: PHYD

Example:

DL:FORM:PSCD OFF
 Applies the user configuration and does not check the received signal

9.8.1.2 Configuring Multicarrier Base Stations

[SENSe][:LTE]:DL:DEMod:MCFilter	201
---	-----

[SENSe][:LTE]:DL:DEMod:MCFilter <State>

This command turns suppression of interfering neighboring carriers on and off (e.g. LTE, WCDMA, GSM etc).

Parameters:

<State> ON | OFF
 *RST: OFF

Example:

DL:DEM:MCF ON
 Turns suppression on of neighboring carriers on.

9.8.1.3 Configuring Parameter Estimation

[SENSe][:LTE]:DL:DEMod:BESTimation.....	201
[SENSe][:LTE]:DL:DEMod:CESTimation.....	201

[SENSe][:LTE]:DL:DEMod:BESTimation <State>

This command turns boosting estimation for downlink signals on and off.

Parameters:

<State> ON | OFF
 *RST: ON

Example:

DL:DEM:BEST ON
 Turns boosting estimation on.

[SENSe][:LTE]:DL:DEMod:CESTimation <Type>

This command selects the channel estimation type for downlink signals.

Parameters:

<Type> **TGPP**
 3GPP EVM definition
 PIL
 Optimal, pilot only
 PILP
 Optimal, pilot and payload
 *RST: TGPP

Example:

DL:DEM:CEST TGPP
 Use 3GPP EVM definition for channel estimation.

9.8.1.4 Compensating Measurement Errors

[SENSe][:LTE]:DL:TRACking:PHASe.....	202
[SENSe][:LTE]:DL:TRACking:TIME.....	202

[SENSe][:LTE]:DL:TRACking:PHASe <Type>

This command selects the phase tracking type for downlink signals.

Parameters:

<Type> **OFF**
Deactivate phase tracking

PIL
Pilot only

PILP
Pilot and payload

*RST: OFF

Example:

DL:TRAC:PHAS PILPAY
Use pilots and payload for phase tracking.

[SENSe][:LTE]:DL:TRACking:TIME <State>

This command turns timing tracking for downlink signals on and off.

Parameters:

<State> ON | OFF

*RST: OFF

Example:

DL:TRAC:TIME ON
Activates timing tracking.

9.8.1.5 Configuring EVM Measurements

[SENSe][:LTE]:DL:DEMod:EVMCalc.....	202
[SENSe][:LTE]:DL:DEMod:PRData.....	202

[SENSe][:LTE]:DL:DEMod:EVMCalc <Calculation>

This command selects the EVM calculation method for downlink signals.

Parameters:

<Calculation> **TGPP**
3GPP definition

OTP
Optimal timing position

*RST: TGPP

Example:

DL:DEM:EVMC TGPP
Use 3GPP method.

[SENSe][:LTE]:DL:DEMod:PRData <Reference>

This command the type of reference data to calculate the EVM for the PDSCH.

Parameters:

<Reference>

AUTO

Automatic identification of reference data.

ALLO

Reference data is 0, according to the test model definition.

Example:

DL:DEM:PRD ALLO

Sets the reference data of the PDSCH to 0.

9.8.1.6 Processing Demodulated Data

[SENSe][:LTE]:DL:DEMod:CBSCrambling.....	203
[SENSe][:LTE]:DL:DEMod:DACHannels.....	203

[SENSe][:LTE]:DL:DEMod:CBSCrambling <State>

This command turns scrambling of coded bits for downlink signals on and off.

Parameters:

<State>

ON | OFF

*RST: ON

Example:

DL:DEM:CBSC ON

Activate scrambling of coded bits.

[SENSe][:LTE]:DL:DEMod:DACHannels <State>

This command turns the decoding of all control channels on and off.

Parameters:

<State>

ON | OFF

*RST: OFF

Example:

DL:DEM:DACH ON

Turns decoding of all control channels on.

9.8.1.7 Configuring MIMO Setups

CONFigure[:LTE]:DL:MIMO:CROStalk.....	203
---------------------------------------	-----

CONFigure[:LTE]:DL:MIMO:CROStalk <State>

This command turns MIMO crosstalk compensation on and off.

Parameters:

<State>

ON | OFF

*RST: OFF

Example:

CONF:DL:MIMO:CROS ON

Turns crosstalk compensation on.

9.8.2 Remote Commands for DL Signal Characteristics

This chapter contains remote commands necessary to define downlink signal characteristics.

For more information see [chapter 5.2, "Defining Downlink Signal Characteristics"](#), on page 95.

- [Defining the Physical Signal Characteristics](#).....204
- [Configuring the Physical Layer Cell Identity](#).....206
- [Configuring MIMO Setups](#).....208
- [Configuring PDSCH Subframes](#).....209

9.8.2.1 Defining the Physical Signal Characteristics

CONFigure[:LTE]:DL[:CC<cci>]:BW	204
CONFigure[:LTE]:DL[:CC<cci>]:CYCPrefix	204
CONFigure[:LTE]:DL[:CC<cci>]:TDD:UDConf	205
CONFigure[:LTE]:DL[:CC<cci>]:TDD:SPSC	205
FETCh[:CC<cci>]:CYCPrefix?	206
FETCh[:CC<cci>]:OSUBcarriers?	206

CONFigure[:LTE]:DL[:CC<cci>]:BW <Bandwidth>

This command selects the channel bandwidth.

Parameters:

<Bandwidth> BW1_40 | BW3_00 | BW5_00 | BW10_00 | BW15_00 |
 BW20_00
 *RST: BW10_00

Example:

Single carrier measurement:
 CONF:DL:BW BW1_40
 Defines a channel bandwidth of 1.4 MHz.

Example:

Aggregated carrier measurement:
 CONF:NOCC 2
 CONF:DL:CC1:BW BW10_00
 CONF:DL:CC2:BW BW5_00
 Selects two carriers, one with a bandwidth of 5 MHz, the other with 10 MHz.

CONFigure[:LTE]:DL[:CC<cci>]:CYCPrefix <PrefixLength>

This command selects the cyclic prefix.

Parameters:

<PrefixLength>

NORM

Normal cyclic prefix length

EXT

Extended cyclic prefix length

AUTO

Automatic cyclic prefix length detection

*RST: AUTO

Example:

Single carrier measurements:

CONF:DL:CYCP EXT

Selects an extended cyclic prefix.

Example:

Aggregated carrier measurements:

CONF:DL:CC1:CYCP EXT

Selects an extended cyclic prefix for the first carrier.

CONFigure[:LTE]:DL[:CC<cci>]:TDD:UDConf <Configuration>

This command selects the subframe configuration for TDD signals.

Parameters:

<Configuration>

Range: 0 to 6

*RST: 0

Example:

Single carrier measurements:

CONF:DL:TDD:UDC 4

Selects allocation configuration number 4.

Example:

Carrier aggregation measurements:

CONF:DL:CC1:TDD:UDC 4

Selects allocation configuration number 4 for the first carrier.

CONFigure[:LTE]:DL[:CC<cci>]:TDD:SPSC <Configuration>

This command selects the special TDD subframe configuration.

Parameters:

<Configuration>

<numeric value>

Numeric value that defines the subframe configuration.

Subframe configurations 7 and 8 are only available if the cyclic prefix is normal.

Range: 0 to 8

*RST: 0

Example:

Single carrier measurements:

CONF:DL:CYCP NORM

CONF:DL:TDD:SPSC 7

Selects subframe configuration 7, available only with a normal cyclic prefix.

Remote Command to Configure the Demodulation

Example: Carrier aggregation measurements:
 CONF:DL:CC1:TDD:SPSC 2
 Selects special subframe configuration 2 for the first carrier.

FETCh[:CC<cci>]:CYCPrefix?

This command queries the cyclic prefix type that has been detected.

Return values:

<PrefixType> The command returns -1 if no valid result has been detected yet.

NORM

Normal cyclic prefix length detected

EXT

Extended cyclic prefix length detected

Example:

FETC:CYCP?

Returns the current cyclic prefix length type.

Usage:

Query only

FETCh[:CC<cci>]:OSUBcarriers?

This command queries the number of occupied carriers as shown in the "Signal Characteristics" dialog box.

Return values:

<Subcarriers> Number of occupied subcarriers.

Example:

FETC:OSUB?

Queries the number of occupied carriers.

Usage:

Query only

9.8.2.2 Configuring the Physical Layer Cell Identity

CONFigure[:LTE]:DL[:CC<cci>]:PLC:CID.....	206
CONFigure[:LTE]:DL[:CC<cci>]:PLC:CIDGroup.....	207
CONFigure[:LTE]:DL[:CC<cci>]:PLC:PLID.....	207
FETCh[:CC<cci>]:PLC:CIDGroup?.....	207
FETCh[:CC<cci>]:PLC:PLID?.....	208

CONFigure[:LTE]:DL[:CC<cci>]:PLC:CID <CellId>

This command defines the cell ID.

Parameters:

<CellId>

AUTO

Automatically defines the cell ID.

<numeric value>

Number of the cell ID.

Range: 0 to 503

Example: CONF:NOCC 2
 CONF:DL:CC1:PLC:CID 12
 CONF:DL:CC2:PLC:CID 15
 Selects 2 carriers and defines a cell ID for each one.

CONFigure[:LTE]:DL[:CC<cci>]:PLC:CIDGroup <GroupNumber>

This command selects the cell ID group for downlink signals.

Parameters:

<GroupNumber> **AUTO**
 Automatic selection
 0...167
 Manual selection
 *RST: AUTO

Example: CONF:DL:PLC:CIDG 134
 Cell identity group number 134 is selected
 CONF:DL:PLC:CIDG AUTO
 Automatic cell identity group detection is selected

CONFigure[:LTE]:DL[:CC<cci>]:PLC:PLID <Identity>

This command defines the physical layer cell identity for ownlink signals.

Parameters:

<Identity> **AUTO**
 Automatic selection
 0...2
 Manual selection
 *RST: AUTO

Example: CONF:DL:PLC:PLID 1
 Selects physical layer cell ID 2.

FETCh[:CC<cci>]:PLC:CIDGroup?

This command queries the cell identity group that has been detected.

Return values:

<CidGroup> The command returns -1 if no valid result has been detected yet.
 Range: 0 to 167

Example: FETC:PLC:CIDG?
 Returns the current cell identity group.

Usage: Query only

FETCH[:CC<cci>]:PLC:PLID?

This command queries the cell identity that has been detected.

Return values:

<Identity> The command returns -1 if no valid result has been detected yet.
Range: 0 to 2

Example:

FETCH:PLC:PLID?
Returns the current cell identity.

Usage:

Query only

9.8.2.3 Configuring MIMO Setups

CONFigure[:LTE]:DL[:CC<cci>]:MIMO:ASElection.....	208
CONFigure[:LTE]:DL[:CC<cci>]:MIMO:CONFig.....	208

CONFigure[:LTE]:DL[:CC<cci>]:MIMO:ASElection <Antenna>

This command selects the antenna for measurements with MIMO setups.

In case of Time Alignment measurements, the command selects the reference antenna.

Parameters:

<Antenna> **ANT1 | ANT2 | ANT3 | ANT4**
Select a single antenna to be analyzed

ALL
Select all antennas to be analyzed

AUT1 | AUT2 | AUT4
Automatically selects the antenna(s) to be analyzed.
AUT1 tests a single antenna, AUT2 tests two antennas, AUT4 tests four antennas.
Available if the number of input channels is taken "From Antenna Selection".

AUTO
Automatically selects the antenna(s) to be analyzed.
*RST: ANT1

CONFigure[:LTE]:DL[:CC<cci>]:MIMO:CONFig <NofAntennas>

This command sets the number of antennas in the MIMO setup.

Parameters:

<NofAntennas> **TX1**
 Use one Tx-antenna

TX2
 Use two Tx-antennas

TX4
 Use four Tx-antennas

*RST: TX1

Example:

```
CONF:DL:MIMO:CONF TX2
```

TX configuration with two antennas is selected.

9.8.2.4 Configuring PDSCH Subframes

CONFigure[:LTE]:DL:CSUBframes.....	209
CONFigure[:LTE]:DL:SUBFrame<subframe>:ALCount.....	209
CONFigure[:LTE]:DL:SUBFrame<subframe>:ALLoc<allocation>:GAP.....	210
CONFigure[:LTE]:DL:SUBFrame<subframe>:ALLoc<allocation>:UEID.....	210
CONFigure[:LTE]:DL:SUBFrame<subframe>:ALLoc<allocation>[:CW<Cwnum>]: MODulation.....	210
CONFigure[:LTE]:DL:SUBFrame<subframe>:ALLoc<allocation>:POWER.....	211
CONFigure[:LTE]:DL:SUBFrame<subframe>:ALLoc<allocation>:PRECoding:AP.....	211
CONFigure[:LTE]:DL:SUBFrame<subframe>:ALLoc<allocation>:PRECoding:CBIndex.....	211
CONFigure[:LTE]:DL:SUBFrame<subframe>:ALLoc<allocation>:PRECoding:CLMapping.....	211
CONFigure[:LTE]:DL:SUBFrame<subframe>:ALLoc<allocation>:PRECoding:CDD.....	212
CONFigure[:LTE]:DL:SUBFrame<subframe>:ALLoc<allocation>:PRECoding[:SCHeme].....	212
CONFigure[:LTE]:DL:SUBFrame<subframe>:ALLoc<allocation>:PRECoding:SCID.....	212
CONFigure[:LTE]:DL:SUBFrame<subframe>:ALLoc<allocation>:PSOffset.....	213
CONFigure[:LTE]:DL:SUBFrame<subframe>:ALLoc<allocation>:RBCount.....	213
CONFigure[:LTE]:DL:SUBFrame<subframe>:ALLoc<allocation>:RBOffset.....	213

CONFigure[:LTE]:DL:CSUBframes <NofSubframes>

This command selects the number of configurable subframes in the downlink signal.

Parameters:

<NofSubframes> Range: 0 to 39
 *RST: 1

Example:

```
CONF:DL:CSUB 5
```

Sets the number of configurable subframes to 5.

CONFigure[:LTE]:DL:SUBFrame<subframe>:ALCount <NofAllocations>

This command defines the number of allocations in a downlink subframe.

Parameters:

<NofAllocations> <numeric value>
 *RST: 1

Example: `CONF:DL:SUBF2:ALC 5`
Defines 5 allocations for subframe 2.

CONFigure[:LTE]:DL:SUBFrame<subframe>:ALLoc<allocation>:GAP <VRBGap>

This command turns the VRB Gap on and off.

Parameters:

<VRBGap> **0**
Selects localized VRBs

1
Selects distributed VRBs and applies the first gap

2
Selects distributed VRBs and applies the second gap (for channel bandwidths > 50 resource blocks)

*RST: 0

Example: `CONF:DL:SUBF2:ALL5:GAP 0`
Selects localized VRBs for allocation 5 in subframe 2.

CONFigure[:LTE]:DL:SUBFrame<subframe>:ALLoc<allocation>:UEID <ID>

This command defines the ID or N_{RNTI}.

Parameters:

<ID> ID of the user equipment.

Example: `CONF:DL:SUBF2:ALL5:UEID 5`
Assigns the ID 5 to allocation 5 in subframe 2.

CONFigure[:LTE]:DL:SUBFrame<subframe>:ALLoc<allocation>[:CW<Cwnum>]: MODulation <Modulation>

This command selects the modulation of an allocation in a downlink subframe.

Suffix:

<Cwnum> 1..n
Selects the codeword.

Parameters:

<Modulation> **QPSK**
QPSK modulation

QAM16
16QAM modulation

QAM64
64QAM modulation

QAM256
256QAM modulation

*RST: QPSK

Remote Command to Configure the Demodulation

Example: `CONF:DL:SUBF2:ALL5:CW2:MOD QAM64`
 Selects a 64QAM modulation for the second codeword of allocation 5 in subframe 2.

CONFigure[LTE]:DL:SUBFrame<subframe>:ALLoc<allocation>:POWER <Power>

This command defines the (relative) power of an allocation in a downlink subframe.

Parameters:

<Power> <numeric value>
 *RST: 0 dB
 Default unit: DB

Example: `CONF:DL:SUBF2:ALL5:POW -1.3`
 Defines a relative power of 1.3 dB for allocation 5 in subframe 2.

CONFigure[LTE]:DL:SUBFrame<subframe>:ALLoc<allocation>:PRECoding:AP <Port>

This command selects the antenna port for the beamforming scheme.

The command is available for measurements on a single antenna.

Parameters:

<Port> 5 | 7 | 8

Example: `CONF:DL:SUBF2:ALL3:PREC:AP 5`
 Selects antenna port 5 for beamforming in allocation 3 in subframe 2.

CONFigure[LTE]:DL:SUBFrame<subframe>:ALLoc<allocation>:PRECoding:CBIndex <CBIndex>

This command selects the codebook index for an allocation with spatial multiplexing precoding scheme.

Parameters:

<CBIndex> 0...15
 *RST: 1

Example: `CONF:DL:SUBF2:ALL4:PREC:CBIN 3`
 Selects codebook index 3 for allocation 4 in subframe number 2.

CONFigure[LTE]:DL:SUBFrame<subframe>:ALLoc<allocation>:PRECoding:CLMapping <Mapping>

This command selects the codeword to layer mapping.

Parameters:

<Mapping> LC11 | LC21 | LC31 | LC41 | LC22 | LC32 | LC42 | LC52 | LC62 |
 LC72 | LC82

Remote Command to Configure the Demodulation

Example: `CONF:DL:SUBF2:ALL3:PREC:CLM LC11`
 Assigns codeword-to-layer mapping 1/1 to allocation 3 in sub-frame 2.

**CONFigure[LTE]:DL:SUBFrame<subframe>:ALLoc<allocation>:PRECoding:
 CDD <State>**

This command turns the cyclic delay diversity of an allocation with spatial multiplexing precoding scheme on and off.

Parameters:

<State> ON | OFF
 *RST: OFF

Example: `CONF:DL:SUBF2:ALL3:PREC:CDD ON`
 Turns the cyclic delay diversity for allocation 3 in subframe 2 on.

**CONFigure[LTE]:DL:SUBFrame<subframe>:ALLoc<allocation>:PRECoding[
 SCHEME] <Scheme>**

This command selects the precoding scheme of an allocation.

Parameters:

<Scheme> **NONE**
 Do not use a precoding scheme.
BF
 Use beamforming scheme.
SPM
 Use spatial multiplexing scheme.
TXD
 Use transmit diversity scheme.
 *RST: NONE

Example: `CONF:DL:SUBF2:ALL3:PREC:SCH SPM`
 Selects the spatial multiplexing precoding scheme for allocation 3 in subframe 2.

**CONFigure[LTE]:DL:SUBFrame<subframe>:ALLoc<allocation>:PRECoding:
 SCID <ID>**

This command selects the scrambling identity (nSCID).

The command is available for antenna ports 7 and 8.

Parameters:

<ID> 0 | 1

Example: `CONF:DL:SUBF2:ALL4:PREC:SCID 1`
 Selects scrambling identity 1 for allocation 4 in subframe 2.

CONFigure[:LTE]:DL:SUBFrame<subframe>:ALLOc<allocation>:PSOFFset
 <PSOFFset>

This command defines the PDSCH start offset for a particular PDSCH allocation.

Parameters:

<PSOFFset> <numeric value>
 Number between 0 and 4.

COMM

Common PDSCH start offset.

Example:

CONF:DL:SUBF2:ALL2:PSOF 0
 Defines a PDSCH start offset of 0 for the 2nd allocation in the 2nd subframe.

CONFigure[:LTE]:DL:SUBFrame<subframe>:ALLOc<allocation>:RBCount
 <ResourceBlocks>

This command selects the number of resource blocks of an allocation in a downlink subframe.

Parameters:

<ResourceBlocks> <numeric value>
 *RST: 6

Example:

CONF:DL:SUBF2:ALL5:RBC 25
 Defines 25 resource block for allocation 5 in subframe 2.

CONFigure[:LTE]:DL:SUBFrame<subframe>:ALLOc<allocation>:RBOFFset
 <Offset>

This command defines the resource block offset of an allocation in a downlink subframe.

Parameters:

<Offset> <numeric value>
 *RST: 0

Example:

CONF:DL:SUBF2:ALL5:RBOF 3
 Defines a resource block offset of 3 for allocation 5 in subframe 2.

9.8.3 Remote Commands for DL Advanced Signal Characteristics

This chapter contains remote commands necessary to define advanced downlink signal characteristics.

For more information see [chapter 5.3, "Defining Advanced Signal Characteristics"](#), on page 105.

- [Configuring the Synchronization Signal](#)..... 214
- [Configuring the Reference Signal](#)..... 215
- [Configuring the Positioning Reference Signal](#)..... 215
- [Configuring the CSI Reference Signal](#)..... 216
- [Configuring the Control Channel](#)..... 218
- [Defining the PDSCH Resource Block Symbol Offset](#)..... 222
- [Configuring Shared Channels](#)..... 223

9.8.3.1 Configuring the Synchronization Signal

CONFigure[:LTE]:DL[:CC<cci>]:SYNC:ANTenna	214
CONFigure[:LTE]:DL:SYNC:PPOWer	214
CONFigure[:LTE]:DL:SYNC:SPOWer	214

CONFigure[:LTE]:DL[:CC<cci>]:SYNC:ANTenna <Antenna>

This command selects the antenna that transmits the P-SYNC and the S-SYNC.

Parameters:

<Antenna> ANT1 | ANT2 | ANT3 | ANT4 | ALL | NONE
 *RST: ALL

Example:

CONF:DL:SYNC:ANT ALL
 All antennas are used to transmit the P-SYNC and S-SYNC.

CONFigure[:LTE]:DL:SYNC:PPOWer <Power>

This command defines the relative power of the P-SYNC.

Parameters:

<Power> <numeric value>
 *RST: 0 dB
 Default unit: DB

Example:

CONF:DL:SYNC:PPOW 0.5
 Sets a relative power of 0.5 dB.

CONFigure[:LTE]:DL:SYNC:SPOWer <Power>

This command defines the relative power of the S-SYNC.

Parameters:

<Power> <numeric value>
 *RST: 0 dB
 Default unit: DB

Example:

CONF:DL:SYNC:SPOW 0.5
 Sets a relative power of 0.5 dB.

9.8.3.2 Configuring the Reference Signal

CONFigure[:LTE]:DL:REFSig:POWer.....215

CONFigure[:LTE]:DL:REFSig:POWer <Power>

This command defines the relative power of the reference signal.

Parameters:

<Power> <numeric value>
 *RST: 0 dB
 Default unit: DB

Example: CONF:DL:REFS:POW -1.2
 Sets a relative power of -1.2 dB.

9.8.3.3 Configuring the Positioning Reference Signal

CONFigure[:LTE]:DL:PRSS:STATe..... 215
 CONFigure[:LTE]:DL:PRSS:BW..... 215
 CONFigure[:LTE]:DL:PRSS:CI..... 215
 CONFigure[:LTE]:DL:PRSS:NPRS.....216
 CONFigure[:LTE]:DL:PRSS:POWer.....216
 CONFigure[:LTE]:DL:SFNO..... 216

CONFigure[:LTE]:DL:PRSS:STATe <State>

This command turns the positioning reference signal on and off.

Parameters:

<State> ON | OFF

Example: CONF:DL:PRSS:STAT ON
 Turns the positioning reference signal on.

CONFigure[:LTE]:DL:PRSS:BW <Bandwidth>

This command defines the bandwidth of the positioning reference signal.

Parameters:

<Bandwidth> BW1_40 | BW3_00 | BW5_00 | BW10_00 | BW15_00 |
 BW20_00
 *RST: BW1_40
 Default unit: MHz

Example: CONF:DL:PRSS:BW BW5_00
 Defines a 5 MHz bandwidth for the positioning reference signal.

CONFigure[:LTE]:DL:PRSS:CI <PRSSConfiguration>

This command selects the configuration index of the Positioning Reference Signal.

Parameters:

<PRSSconfiguration> Number of the configuration index.

Example:

```
CONF:DL:PRSS:CI 2
```

Selects configuration index 2 for the positioning reference signal.

CONFigure[:LTE]:DL:PRSS:NPRS <NofDLSubframes>

This command defines the number of subframes the Positioning Reference Signal occupies.

Parameters:

<NofDLSubframes> 1 | 2 | 4 | 6

Example:

```
CONF:DL:PRSS:NPRS 1
```

Defines 1 subframe for the poitioning reference signal.

CONFigure[:LTE]:DL:PRSS:POWER <Power>

This command defines the relative power of the Positioning Reference Signal.

Parameters:

<Power> Default unit: dB

Example:

```
CONF:DL:PRSS:POW 1
```

Defines a relative power of 1 dB for the positioning reference signal.

CONFigure[:LTE]:DL:SFNO <Offset>

This command defines the frame number offset for the positioning reference signal.

Parameters:

<Offset> <numeric value>

Example:

```
CONF:DL:SFNO 4
```

Defines a frame number offset of 4.

9.8.3.4 Configuring the CSI Reference Signal

CONFigure[:LTE]:DL:CSIRs:CI.....	216
CONFigure[:LTE]:DL:CSIRs:NAP.....	217
CONFigure[:LTE]:DL:CSIRs:OPDSch.....	217
CONFigure[:LTE]:DL:CSIRs:POWER.....	217
CONFigure[:LTE]:DL:CSIRs:SCI.....	217
CONFigure[:LTE]:DL:CSIRs:STATE.....	218

CONFigure[:LTE]:DL:CSIRs:CI <Index>

This command selects the configuration index for the CSI reference signal.

Parameters:

<Index> MNEM
 Number of the configuration index.
 Range: 0 to 31

Example:

CONF:DL:CSIR:CI 12
 Selects configuration index 12 for the CSI reference signal.

CONFigure[:LTE]:DL:CSIRs:NAP <Ports>

This command selects the number of antenna ports that transmit the CSI reference signal.

Parameters:

<Ports> **TX1**
 TX2
 TX4
 TX8

Example:

CONF:DL:CSIR:NAP TX2
 Selects 2 antenna ports for the CSI reference signal transmission.

CONFigure[:LTE]:DL:CSIRs:OPDSch <State>

This command turns overwriting of PDSCH resource elements for UEs that do not consider the CSI reference signal on and off.

Parameters:

<State> **ON**
 The CSI reference signal overwrite PDSCH resource elements.
 OFF
 PDSCH resource elements remain.

Example:

CONF:DL:CSIR:OPDS ON
 Overwrites PDSCH resource elements if necessary.

CONFigure[:LTE]:DL:CSIRs:POWer <Power>

This command defines the relative power of the CSI reference signal.

Parameters:

<Power> Default unit: dB

Example:

CONF:DL:CSIR:POW 1
 Defines a relative power of 1 dB for the CSI reference signal.

CONFigure[:LTE]:DL:CSIRs:SCI <Configuration>

This command defines the subframe configuration for the CSI reference signal.

Parameters:

<Configuration> Number that selects the subframe configuration.
 Range: 0 to 154

Example:

CONF:DL:CSIR:SCI 4
 Selects subframe configuration 4 for the CSI reference signal.

CONFigure[:LTE]:DL:CSIRs:STATe <State>

This command turns the CSI reference signal on and off.

Parameters:

<State> ON | OFF

Example:

CONF:DL:CSIR:STAT ON
 Turns the CSI reference signal on.

9.8.3.5 Configuring the Control Channel

CONFigure[:LTE]:DL:EPDCch:LOCalized.....	218
CONFigure[:LTE]:DL:EPDCch:NPRB.....	219
CONFigure[:LTE]:DL:EPDCch:POWer.....	219
CONFigure[:LTE]:DL:EPDCch:RBASsign.....	219
CONFigure[:LTE]:DL:EPDCch:SID.....	219
CONFigure[:LTE]:DL:PBCH:STAT.....	219
CONFigure[:LTE]:DL:PCFich:STAT.....	220
CONFigure[:LTE]:DL:PHICH:DURation.....	220
CONFigure[:LTE]:DL:PHICH:NGParameter.....	220
CONFigure[:LTE]:DL:PDCCh:FORMat.....	220
CONFigure[:LTE]:DL:PHICH:MITM.....	221
CONFigure[:LTE]:DL:PHICH:NOGRoups.....	221
CONFigure[:LTE]:DL:PDCCh:NOPD.....	221
CONFigure[:LTE]:DL:PBCH:POWer.....	221
CONFigure[:LTE]:DL:PCFich:POWer.....	222
CONFigure[:LTE]:DL:PHICH:POWer.....	222
CONFigure[:LTE]:DL:PDCCh:POWer.....	222

CONFigure[:LTE]:DL:EPDCch:LOCalized <State>

This command turns localized transmission of the EPDCCH on and off.

Parameters:

<State> ON | OFF
 *RST: ON

Example:

CONF:DL:EPDC:LOC OFF
 Turns on distributed transmission of the EPDCCH.

CONFigure[:LTE]:DL:EPDCch:NPRB <NofPRBPairs>

This command selects the number of resource blocks that the EPDCCH-PRB set uses.

Parameters:

<NofPRBPairs> MNEM | ASEL

CONFigure[:LTE]:DL:EPDCch:POWER <Power>

This command defines the relative power of the EPDCCH.

Parameters:

<Power> <numeric value>
 *RST: 0 dB
 Default unit: DB

Example:

CONF:DL:EPDC:POW -0.5
 Sets the relative power to -0.5 dB.

CONFigure[:LTE]:DL:EPDCch:RBASsign <RBAssignment>

This command defines the resource blocks that the EPDCCH uses.

Parameters:

<RBAssignment>

Example:

CONF:DL:EPDC:RBAS 2

CONFigure[:LTE]:DL:EPDCch:SID <SetID>

This command defines the EPDCCH set ID used to generate EPDCCH reference symbols.

Parameters:

<SetID> Range: 0 to 503
 *RST: 0

Example:

CONF:DL:EPDC:SID 10
 Selects set ID 10.

CONFigure[:LTE]:DL:PBCH:STAT <State>

This command turns the PBCH on and off.

Parameters:

<State> ON | OFF
 *RST: ON

Example:

CONF:DL:PBCH:STAT ON
 Activates the PBCH.

CONFigure[:LTE]:DL:PCFich:STAT <State>

This command turns the PCFICH on and off.

Parameters:

<State> ON | OFF
*RST: ON

Example:

CONF:DL:PCF:STAT ON
Activates the PCFICH.

CONFigure[:LTE]:DL:PHICH:DURation <Duration>

This command selects the PHICH duration.

Parameters:

<Duration> **NORM**
Normal
EXT
Extended
*RST: NORM

Example:

CONF:DL:PHIC:DUR NORM
Selects normal PHICH duration.

CONFigure[:LTE]:DL:PHICH:NGParameter <Ng>

This command selects the method that determines the number of PHICH groups in a subframe.

Parameters:

<Ng> NG1_6 | NG1_2 | NG1 | NG2 | NGCUSTOM
Select NGCUSTOM to customize N_g . You can then define the variable as you like with [CONFigure\[:LTE\]:DL:PHICH:NOGRoups](#).
*RST: NG1_6

Example:

CONF:DL:PHIC:NGP NG1_6
Sets N_g to 1/6. The number fo PHICH groups in the subframe depends on the number of resource blocks.
CONF:DL:PHIC:NGP NGCUSTOM
Define a customized value for N_g .
CONF:DL:PHIC:NOGR 5
Directly sets the number of PHICH groups in the subframe to 5.

CONFigure[:LTE]:DL:PDCCh:FORMat <Format>

This command selects the PDCCH format.

Remote Command to Configure the Demodulation

Parameters:

<Format> -1 | 0 | 1 | 2 | 3
 *RST: -1

Example:

CONF:DL:PDCCH:FORM 0
 Sets the PDDCH format to 0.

CONFigure[:LTE]:DL:PHICH:MITM <State>

This command includes or excludes the use of the PHICH special setting for enhanced test models.

Parameters:

<State> ON | OFF
 *RST: OFF

Example:

CONF:DL:PHICH:MITM ON
 Activates PHICH TDD m_i=1 (E-TM)

CONFigure[:LTE]:DL:PHICH:NOGRoups <NofGroups>

This command sets the number of PHICH groups.

Parameters:

<NofGroups> <numeric value>
 *RST: 0

Example:

CONF:DL:PHICH:NOGR 5
 Sets number of PHICH groups to 5.

CONFigure[:LTE]:DL:PDCCh:NOPD <NofPDCCH>

This command sets the number of PDCCHs.

Parameters:

<NofPDCCH> <numeric value>
 *RST: 0

Example:

CONF:DL:PDCCH:NOPD 3
 Sets the number of DPCCHs to 3.

CONFigure[:LTE]:DL:PBCH:POWER <Power>

This command defines the relative power of the PBCH.

Parameters:

<Power> <numeric value>
 *RST: 0 dB
 Default unit: DB

Example: `CONF:DL:PBCH:POW -1.1`
Sets the relative power to -1.1 dB.

CONFigure[:LTE]:DL:PCFich:POWer <Power>

This command defines the relative power of the PCFICH.

Parameters:

<Power> <numeric value>
*RST: 0 dB
Default unit: DB

Example: `CONF:DL:PCF:POW 0`
Sets the relative power to 0 dB.

CONFigure[:LTE]:DL:PHICH:POWer <Power>

This command defines the relative power of the PHICH.

Parameters:

<Power> <numeric value>
*RST: -3.01 dB
Default unit: DB

Example: `CONF:DL:PHIC:POW -1.3`
Sets the relative power to -1.3 dB.

CONFigure[:LTE]:DL:PDCCh:POWer <Power>

This command defines the relative power of the PDCCH.

Parameters:

<Power> <numeric value>
*RST: 0 dB
Default unit: DB

Example: `CONF:DL:PDCCH:POW -1.2`
Sets the relative power to -1.2 dB.

9.8.3.6 Defining the PDSCH Resource Block Symbol Offset

[CONFigure\[:LTE\]:DL:PSOffset](#)..... 222

CONFigure[:LTE]:DL:PSOffset <Offset>

This command defines the symbol offset for PDSCH allocations relative to the start of the subframe.

The offset applies to all subframes.

Parameters:

<Offset>

AUTO

Automatically determines the symbol offset.

<numeric value>

Manual selection of the symbol offset.

Range: 0 to 4

*RST: AUTO

Example:

CONF:DL:PSOF 2

Sets an offset of 2 symbols.

9.8.3.7 Configuring Shared Channels

CONFigure[LTE]:DL:PDSCh:PB..... 223

CONFigure[LTE]:DL:PDSCh:PB <PDSChPB>

This command selects the PDSCH power ratio.

Note that the power ratio depends on the number of antennas in the system.

Parameters:

<PDSChPB>

Numeric value that defines PDSCH P_B which defines the power ratio in dB.

0**1****2****3**See [PDSCH Power Ratio](#) for an overview of resulting power ratios.**RAT1**

Ratio = 1, regardless of the number of antennas.

Example:

CONF:DL:PDSC:PB 3

Selects the PDSCH P_B '3'.

9.8.4 Remote Commands for MBSFN Settings

This chapter contains remote commands necessary to include an MBSFN in the test setup.

For more information see [chapter 5.4, "Defining MBSFN Characteristics"](#), on page 116.

- [MBSFN Settings](#).....224
- [MBSFN Subframe Configuration](#).....225

9.8.4.1 MBSFN Settings

CONFigure[:LTE]:DL:MBSFn:AI:ID.....	224
CONFigure[:LTE]:DL:MBSFn:AI:NMRL.....	224
CONFigure[:LTE]:DL:MBSFn:POWer.....	224
CONFigure[:LTE]:DL:MBSFn:STATe.....	224

CONFigure[:LTE]:DL:MBSFn:AI:ID <Configuration>

Defines the ID of an MBFSN area.

Parameters:

<Configuration> Range: 0 to 255

Example:

CONF:DL:MBSF:AI:ID 2

Defines an area for the multimedia broadcast network.

CONFigure[:LTE]:DL:MBSFn:AI:NMRL <Configuration>

This command selects the length of the control data region in an MBSFN subframe.

Parameters:

<Configuration> **1**
 The first symbol in a subframe carries data of the control channel.

2
 The first two symbols in a subframe carries data of the control channel.

Example:

CONF:DL:MBSF:AI:NMRL 2

Selects two symbols that carry control channel data.

CONFigure[:LTE]:DL:MBSFn:POWer <Power>

This command defines the relative power of the MBSFN transmission.

Parameters:

<Power> *RST: 0 dB
 Default unit: DB

Example:

CONF:DL:MBSF:POW -1.5

Defines a relative power of -1.5 dB.

CONFigure[:LTE]:DL:MBSFn:STATe <State>

This command includes or excludes an MBSFN from the test setup.

Parameters:

<State> ON | OFF
 *RST: OFF

Example: `CONF:DL:MBSF:STAT ON`
Includes an MBSFN in the test setup.

9.8.4.2 MBSFN Subframe Configuration

<code>CONFigure[:LTE]:DL:MBSFn:SUBFrame<subframe>:PMCH:MODulation</code>	225
<code>CONFigure[:LTE]:DL:MBSFn:SUBFrame<subframe>:PMCH:STATe</code>	225
<code>CONFigure[:LTE]:DL:MBSFn:SUBFrame<subframe>:STATe</code>	225

`CONFigure[:LTE]:DL:MBSFn:SUBFrame<subframe>:PMCH:MODulation` <Modulation>

This command selects the modulation type for an MBSFN subframe.

Parameters:
<Modulation> QPSK | QAM16 | QAM64 | QAM256
*RST: QPSK

Example: `CONF:DL:MBSF:SUBF2:PMCH:MOD QPSK`
Selects QPSK modulation for the second subframe.

`CONFigure[:LTE]:DL:MBSFn:SUBFrame<subframe>:PMCH:STATe` <State>

This command turns the PMCH in an MBSFN subframe on and off.

Note that you first have to turn a subframe into a MBSFN subframe with
`CONFigure[:LTE]:DL:MBSFn:SUBFrame<subframe>:STATe`.

Parameters:
<State> ON | OFF

Example: `CONF:DL:MBSF:SUBF2:PMCH:STAT ON`
Turns the PMCH in the second subframe on.

`CONFigure[:LTE]:DL:MBSFn:SUBFrame<subframe>:STATe` <State>

This command turns a subframe into an MBSFN subframe.

Parameters:
<State> ON | OFF
*RST: OFF

Example: `CONF:DL:MBSF:SUBF2:STAT ON`
Turns the second subframe into an MBSFN subframe.

9.9 Configuring the Software

<code>CONFigure:PRESet</code>	226
<code>DISPlay[:WINDow<n>]:SElect</code>	226

CONFigure:PRESet

Initiates a preset to the default state of the software, and, if connected to an analyzer, also presets the analyzer.

Example: CONF:PRES
 Presets the software.

Usage: Event

DISPlay[:WINDow<n>]:SElect

This command selects the measurement window.

Example: DISP:WIND2:SEL
 Selects screen B.

Usage: Event

9.10 Managing Files

FORMat[:DATA].....	226
MMEMory:LOAD:DEModsetting.....	226
MMEMory:LOAD:IQ:STATe.....	227
MMEMory:LOAD:TMOD:DL.....	227
MMEMory:STORe:DEModsetting.....	227
MMEMory:STORe:IQ:STATe.....	228

FORMat[:DATA] [<Format>]

This command specifies the data format for the data transmission between the LTE measurement application and the remote client. Supported formats are ASCII or REAL32.

Parameters:
<Format> ASCIi | REAL
 *RST: ASCIi

Example: FORM REAL
 The software will send binary data in Real32 data format.

MMEMory:LOAD:DEModsetting <Path>

This command restores previously saved demodulation settings.

The file must be of type "*.allocation" and depends on the link direction that was currently selected when the file was saved. You can load only files with correct link directions.

Setting parameters:
<Path> String containing the path and name of the file.

Example: `MMEM:LOAD:DEM 'D:\USER\Settingsfile.allocation'`

Usage: Setting only

MMEMory:LOAD:IQ:STATE <Path>

This command restores I/Q data from a file.

Setting parameters:

<Path> String containing the path and name of the source file.

Example: `MMEM:LOAD:IQ:STAT 'C:\R_S\Instr\user\data.iq.tar'`
Loads I/Q data from the specified file.

Usage: Setting only

MMEMory:LOAD:TMOD:DL <TestModel>

This command loads an EUTRA test model (E-TM).

The test models are in accordance with 3GPP TS 36.141.

Setting parameters:

<TestModel> **'E-TM1_1_20MHz'**
EUTRA Test Model 1.1 (E-TM1.1)

'E-TM1_2_20MHz'
EUTRA Test Model 1.2 (E-TM1.2)

'E-TM2_20MHz'
EUTRA Test Model 2 (E-TM2)

'E-TM3_1_20MHz'
EUTRA Test Model 3.1 (E-TM3.1)

'E-TM3_2_20MHz'
EUTRA Test Model 3.2 (E-TM3.2)

'E-TM3_3_20MHz'
EUTRA Test Model 3.3 (E-TM3.3)

To select a test model for a different bandwidth, replace "20MHz" with either "1_4MHz", "3MHz", "5MHz", "10MHz" or "15MHz".

Example: `MMEM:LOAD:TMOD:DL 'E-TM2_10MHz'`
Selects test model 2 for a 10 MHz bandwidth.

Usage: Setting only

MMEMory:STORe:DEModsetting <Path>

Stores the current demodulation settings to a file. The resulting file type is "*.allocation". Existing files will be overwritten.

Setting parameters:

<Path> String containing the path and name of the file.

Example: MMEM:STOR:DEM 'D:\USER\Settingsfile.allocation'

Usage: Setting only

MMEMory:STORe:IQ:STATe <Path>

This command saves I/Q data to a file.

Setting parameters:

<Path> String containing the path and name of the target file.

Example: MMEM:STOR:IQ:STAT 'C:
\R_S\Instr\user\data.iq.tar'
Saves I/Q data to the specified file.

Usage: Setting only

List of Commands

[SENSe]:FREQUency:CENTer[:CC<cci>].....	182
[SENSe]:IQ:DITHer[:STATe].....	197
[SENSe]:IQ:LPASs[:STATe].....	197
[SENSe]:POWer:ACHannel:AACHannel.....	195
[SENSe]:POWer:AUTO<instrument>:TIME.....	197
[SENSe]:POWer:AUTO<instrument>[:STATe].....	183
[SENSe]:POWer:NCORrection.....	195
[SENSe]:POWer:SEM:CATegory.....	194
[SENSe]:POWer:SEM:CHBS:AMPower.....	198
[SENSe]:POWer:SEM:CHBS:AMPower:AUTO.....	194
[SENSe]:SWAPiq.....	196
[SENSe]:SWEep:EGATe:AUTO.....	195
[SENSe]:SWEep:TIME.....	185
[SENSe]:SYNC[:STATe]?.....	150
[SENSe][:LTE]:ANTenna:SElect.....	187
[SENSe][:LTE]:DL:DEMod:AUTO.....	200
[SENSe][:LTE]:DL:DEMod:BEStimation.....	201
[SENSe][:LTE]:DL:DEMod:CBSCrambling.....	203
[SENSe][:LTE]:DL:DEMod:CEStimation.....	201
[SENSe][:LTE]:DL:DEMod:DACHannels.....	203
[SENSe][:LTE]:DL:DEMod:EVMCalc.....	202
[SENSe][:LTE]:DL:DEMod:MCFilter.....	201
[SENSe][:LTE]:DL:DEMod:PRData.....	202
[SENSe][:LTE]:DL:FORMat:PSCD.....	200
[SENSe][:LTE]:DL:TRACking:PHASe.....	202
[SENSe][:LTE]:DL:TRACking:TIME.....	202
[SENSe][:LTE]:FRAMe:COUNT.....	185
[SENSe][:LTE]:FRAMe:COUNT:AUTO.....	186
[SENSe][:LTE]:FRAMe:COUNT:STATe.....	185
[SENSe][:LTE]:FRAMe:SCOnt.....	186
[SENSe][:LTE]:OOPower:ATIMing.....	150
[SENSe][:LTE]:OOPower:CAGGregation.....	189
[SENSe][:LTE]:OOPower:FREQUency:HIGHer.....	189
[SENSe][:LTE]:OOPower:FREQUency:LOWer.....	190
[SENSe][:LTE]:OOPower:NCORrection.....	190
[SENSe][:LTE]:SOURce:SElect.....	188
[SENSe][:LTE]:SUBFrame:SElect.....	188
CALCulate<n>:FEED.....	147
CALCulate<n>:LIMit<k>:ACPoweR:ACHannel:RESult?.....	173
CALCulate<n>:LIMit<k>:ACPoweR:ALTerNate:RESult?.....	174
CALCulate<n>:LIMit<k>:OOPower:OFFPower?.....	175
CALCulate<n>:LIMit<k>:OOPower:TRANsient?.....	176
CALCulate<n>:LIMit<k>:SUMMary:EVM:DSQP:MAXimum:RESult?.....	177
CALCulate<n>:LIMit<k>:SUMMary:EVM:DSQP[:AVERAge]:RESult?.....	177
CALCulate<n>:LIMit<k>:SUMMary:EVM:DSSF:MAXimum:RESult?.....	178
CALCulate<n>:LIMit<k>:SUMMary:EVM:DSSF[:AVERAge]:RESult?.....	178
CALCulate<n>:LIMit<k>:SUMMary:EVM:DSST:MAXimum:RESult?.....	178

CALCulate<n>:LIMit<k>:SUMMary:EVM:DSST[:AVERAge]:RESult?	178
CALCulate<n>:LIMit<k>:SUMMary:EVM:PCHannel:MAXimum:RESult?	178
CALCulate<n>:LIMit<k>:SUMMary:EVM:PCHannel[:AVERAge]:RESult?	178
CALCulate<n>:LIMit<k>:SUMMary:EVM:PSIGnal:MAXimum:RESult?	179
CALCulate<n>:LIMit<k>:SUMMary:EVM:PSIGnal[:AVERAge]:RESult?	179
CALCulate<n>:LIMit<k>:SUMMary:EVM[:ALL]:MAXimum:RESult?	177
CALCulate<n>:LIMit<k>:SUMMary:EVM[:ALL]:[:AVERAge]:RESult?	177
CALCulate<n>:LIMit<k>:SUMMary:FERRor:MAXimum:RESult?	179
CALCulate<n>:LIMit<k>:SUMMary:FERRor[:AVERAge]:RESult?	179
CALCulate<n>:LIMit<k>:SUMMary:GIMBalance:MAXimum:RESult?	180
CALCulate<n>:LIMit<k>:SUMMary:GIMBalance[:AVERAge]:RESult?	180
CALCulate<n>:LIMit<k>:SUMMary:IQOffset:MAXimum:RESult?	180
CALCulate<n>:LIMit<k>:SUMMary:IQOffset[:AVERAge]:RESult?	180
CALCulate<n>:LIMit<k>:SUMMary:QUADerror:MAXimum:RESult?	180
CALCulate<n>:LIMit<k>:SUMMary:QUADerror[:AVERAge]:RESult?	180
CALCulate<n>:LIMit<k>:SUMMary:SERRor:MAXimum:RESult?	181
CALCulate<n>:LIMit<k>:SUMMary:SERRor[:AVERAge]:RESult?	181
CALCulate<n>:MARKer<m>:FUNction:POWer:RESult[:CURRent]?	175
CALibration:PHASe:GENerate	149
CALibration:PHASe:LOAD	149
CONFigure:ACONfig<instrument>:ADDress	190
CONFigure:ACONfig<instrument>:ICSequence	191
CONFigure:ACONfig<instrument>:NCHannels	191
CONFigure:NOCC	189
CONFigure:POWer:EXPEcted:IQ<instrument>	184
CONFigure:POWer:EXPEcted:RF<instrument>	184
CONFigure:PRESet	226
CONFigure[:LTE]:DL:BF:AP	150
CONFigure[:LTE]:DL:CONS:LOCation	150
CONFigure[:LTE]:DL:CSIRs:CI	216
CONFigure[:LTE]:DL:CSIRs:NAP	217
CONFigure[:LTE]:DL:CSIRs:OPDSch	217
CONFigure[:LTE]:DL:CSIRs:POWer	217
CONFigure[:LTE]:DL:CSIRs:SCI	217
CONFigure[:LTE]:DL:CSIRs:STATe	218
CONFigure[:LTE]:DL:CSUBframes	209
CONFigure[:LTE]:DL:EPDCch:LOCalized	218
CONFigure[:LTE]:DL:EPDCch:NPRB	219
CONFigure[:LTE]:DL:EPDCch:POWer	219
CONFigure[:LTE]:DL:EPDCch:RBASsign	219
CONFigure[:LTE]:DL:EPDCch:SID	219
CONFigure[:LTE]:DL:MBSFn:AI:ID	224
CONFigure[:LTE]:DL:MBSFn:AI:NMRL	224
CONFigure[:LTE]:DL:MBSFn:POWer	224
CONFigure[:LTE]:DL:MBSFn:STATe	224
CONFigure[:LTE]:DL:MBSFn:SUBFrame<subframe>:PMCH:MODulation	225
CONFigure[:LTE]:DL:MBSFn:SUBFrame<subframe>:PMCH:STATe	225
CONFigure[:LTE]:DL:MBSFn:SUBFrame<subframe>:STATe	225
CONFigure[:LTE]:DL:MIMO:CROStalk	203
CONFigure[:LTE]:DL:PBCH:POWer	221

CONFigure[LTE]:DL:PBCH:STAT.....	219
CONFigure[LTE]:DL:PCFich:POWer.....	222
CONFigure[LTE]:DL:PCFich:STAT.....	220
CONFigure[LTE]:DL:PDCCh:FORMat.....	220
CONFigure[LTE]:DL:PDCCh:NOPD.....	221
CONFigure[LTE]:DL:PDCCh:POWer.....	222
CONFigure[LTE]:DL:PDSCCh:PB.....	223
CONFigure[LTE]:DL:PHICCh:DURation.....	220
CONFigure[LTE]:DL:PHICCh:MITM.....	221
CONFigure[LTE]:DL:PHICCh:NGParameter.....	220
CONFigure[LTE]:DL:PHICCh:NOGRoups.....	221
CONFigure[LTE]:DL:PHICCh:POWer.....	222
CONFigure[LTE]:DL:PRSS:BW.....	215
CONFigure[LTE]:DL:PRSS:CI.....	215
CONFigure[LTE]:DL:PRSS:NPRS.....	216
CONFigure[LTE]:DL:PRSS:POWer.....	216
CONFigure[LTE]:DL:PRSS:STATe.....	215
CONFigure[LTE]:DL:PSOOffset.....	222
CONFigure[LTE]:DL:REFSig:POWer.....	215
CONFigure[LTE]:DL:SFNO.....	216
CONFigure[LTE]:DL:SUBFrame<subframe>:ALCount.....	209
CONFigure[LTE]:DL:SUBFrame<subframe>:ALLoc<allocation>:GAP.....	210
CONFigure[LTE]:DL:SUBFrame<subframe>:ALLoc<allocation>:POWer.....	211
CONFigure[LTE]:DL:SUBFrame<subframe>:ALLoc<allocation>:PRECoding:AP.....	211
CONFigure[LTE]:DL:SUBFrame<subframe>:ALLoc<allocation>:PRECoding:CBINdex.....	211
CONFigure[LTE]:DL:SUBFrame<subframe>:ALLoc<allocation>:PRECoding:CDD.....	212
CONFigure[LTE]:DL:SUBFrame<subframe>:ALLoc<allocation>:PRECoding:CLMapping.....	211
CONFigure[LTE]:DL:SUBFrame<subframe>:ALLoc<allocation>:PRECoding:SCID.....	212
CONFigure[LTE]:DL:SUBFrame<subframe>:ALLoc<allocation>:PRECoding[:SCHeme].....	212
CONFigure[LTE]:DL:SUBFrame<subframe>:ALLoc<allocation>:PSOOffset.....	213
CONFigure[LTE]:DL:SUBFrame<subframe>:ALLoc<allocation>:RBCount.....	213
CONFigure[LTE]:DL:SUBFrame<subframe>:ALLoc<allocation>:RBOffset.....	213
CONFigure[LTE]:DL:SUBFrame<subframe>:ALLoc<allocation>:UEID.....	210
CONFigure[LTE]:DL:SUBFrame<subframe>:ALLoc<allocation>[:CW<Cwnum>]:MODulation.....	210
CONFigure[LTE]:DL:SYNC:PPOWer.....	214
CONFigure[LTE]:DL:SYNC:SPOWer.....	214
CONFigure[LTE]:DL[:CC<cci>]:BW.....	204
CONFigure[LTE]:DL[:CC<cci>]:CYCPrefix.....	204
CONFigure[LTE]:DL[:CC<cci>]:MIMO:ASElection.....	208
CONFigure[LTE]:DL[:CC<cci>]:MIMO:CONFig.....	208
CONFigure[LTE]:DL[:CC<cci>]:MIMO:SUAP.....	199
CONFigure[LTE]:DL[:CC<cci>]:PLC:CID.....	206
CONFigure[LTE]:DL[:CC<cci>]:PLC:CIDGroup.....	207
CONFigure[LTE]:DL[:CC<cci>]:PLC:PLID.....	207
CONFigure[LTE]:DL[:CC<cci>]:SYNC:ANTenna.....	214
CONFigure[LTE]:DL[:CC<cci>]:TDD:SPSC.....	205
CONFigure[LTE]:DL[:CC<cci>]:TDD:UDConf.....	205
CONFigure[LTE]:DUPLexing.....	182
CONFigure[LTE]:LDIRection.....	182
CONFigure[LTE]:NSources.....	191

CONFigure[LTE]:OOPower:NFRames.....	190
DISPlay[WINDow<n>]:SElect.....	226
DISPlay[WINDow<n>]:TABLe.....	148
DISPlay[WINDow<n>]:TRACe<t>:Y[:SCALe]:RLEVel:OFFSet.....	185
FETCh:SUMMary:CRESt:MAXimum?.....	152
FETCh:SUMMary:CRESt:MINimum?.....	152
FETCh:SUMMary:CRESt[:AVERAge]?.....	152
FETCh:SUMMary:EVM:DSQP:MAXimum?.....	153
FETCh:SUMMary:EVM:DSQP:MINimum?.....	153
FETCh:SUMMary:EVM:DSQP[:AVERAge]?.....	153
FETCh:SUMMary:EVM:DSSF:MAXimum?.....	153
FETCh:SUMMary:EVM:DSSF:MINimum?.....	153
FETCh:SUMMary:EVM:DSSF[:AVERAge]?.....	153
FETCh:SUMMary:EVM:DSST:MAXimum?.....	153
FETCh:SUMMary:EVM:DSST:MINimum?.....	153
FETCh:SUMMary:EVM:DSST[:AVERAge]?.....	153
FETCh:SUMMary:EVM:PCHannel:MAXimum?.....	154
FETCh:SUMMary:EVM:PCHannel:MINimum?.....	154
FETCh:SUMMary:EVM:PCHannel[:AVERAge]?.....	154
FETCh:SUMMary:EVM:PSIGnal:MAXimum?.....	154
FETCh:SUMMary:EVM:PSIGnal:MINimum?.....	154
FETCh:SUMMary:EVM:PSIGnal[:AVERAge]?.....	154
FETCh:SUMMary:EVM[:ALL]:MAXimum?.....	152
FETCh:SUMMary:EVM[:ALL]:MINimum?.....	152
FETCh:SUMMary:EVM[:ALL][:AVERAge]?.....	152
FETCh:SUMMary:FERRor:MAXimum?.....	154
FETCh:SUMMary:FERRor:MINimum?.....	154
FETCh:SUMMary:FERRor[:AVERAge]?.....	154
FETCh:SUMMary:GIMBalance:MAXimum?.....	155
FETCh:SUMMary:GIMBalance:MINimum?.....	155
FETCh:SUMMary:GIMBalance[:AVERAge]?.....	155
FETCh:SUMMary:IQOFfset:MAXimum?.....	155
FETCh:SUMMary:IQOFfset:MINimum?.....	155
FETCh:SUMMary:IQOFfset[:AVERAge]?.....	155
FETCh:SUMMary:OSTP:MAXimum?.....	155
FETCh:SUMMary:OSTP:MINimum?.....	155
FETCh:SUMMary:OSTP[:AVERAge]?.....	155
FETCh:SUMMary:POWer:MAXimum?.....	156
FETCh:SUMMary:POWer:MINimum?.....	156
FETCh:SUMMary:POWer[:AVERAge]?.....	156
FETCh:SUMMary:QUADerror:MAXimum?.....	156
FETCh:SUMMary:QUADerror:MINimum?.....	156
FETCh:SUMMary:QUADerror[:AVERAge]?.....	156
FETCh:SUMMary:RSSI:MAXimum?.....	157
FETCh:SUMMary:RSSI:MINimum?.....	157
FETCh:SUMMary:RSSI[:AVERAge]?.....	157
FETCh:SUMMary:RSTP:MAXimum?.....	157
FETCh:SUMMary:RSTP:MINimum?.....	157
FETCh:SUMMary:RSTP[:AVERAge]?.....	157
FETCh:SUMMary:SERRor:MAXimum?.....	157

FETCh:SUMMary:SERRor:MINimum?	157
FETCh:SUMMary:SERRor[:AVERage]?	157
FETCh:SUMMary:TFRame?	157
FETCh:TAERror[:CC<cci>]:ANTenna<antenna>:MAXimum?	158
FETCh:TAERror[:CC<cci>]:ANTenna<antenna>:MINimum?	158
FETCh:TAERror[:CC<cci>]:ANTenna<antenna>[:AVERage]?	158
FETCh[:CC<cci>]:CYCPrefix?	206
FETCh[:CC<cci>]:OSUBcarriers?	206
FETCh[:CC<cci>]:PLC:CIDGroup?	207
FETCh[:CC<cci>]:PLC:PLID?	208
FETCh[:CC<cci>]:SUMMary:RFERror[:AVERage]?	156
FORMat[:DATA]	226
INITiate:REFResh	149
INITiate[:IMMediate]	149
INPut:IQ:BALanced[:STATe]	197
INPut:IQ:FSoFfset	196
INPut:IQ:IMPedance	196
INPut<n>:ATTenuation<instrument>	184
INPut<n>:DIQ:RANGe[:UPPer]	198
INPut<n>:DIQ:SRATe	198
MMEMory:LOAD:DEModsetting	226
MMEMory:LOAD:IQ:STATe	227
MMEMory:LOAD:TMOD:DL	227
MMEMory:STORe:DEModsetting	227
MMEMory:STORe:IQ:STATe	228
SENSe:INPut	183
TRACe[:DATA]?	173
TRIGger[:SEQuence]:HOLDoff<instrument>	192
TRIGger[:SEQuence]:LEVel<instrument>:POWer	193
TRIGger[:SEQuence]:LEVel<instrument>[:EXTeRnal]	193
TRIGger[:SEQuence]:MODE	192
TRIGger[:SEQuence]:PORT<instrument>	193
TRIGger[:SEQuence]:SLOPe	193
UNIT:BSTR	187
UNIT:CAXes	187
UNIT:EVM	187

Index

A

ACLR	47
Allocation ID vs symbol x carrier	57
Allocation summary	55
Auto Detection (Cell Identity)	98
Auto PDSCH Demodulation	89

B

Balanced Input	86
Beamform Allocation Summary	63
Bit stream	56
Boosting estimation	91

C

Capture buffer	34
Capture Time	73
CCDF	54
Cell ID	98
Cell Identity Group	98
Cell RS Weights (Phase)	64
Channel Bandwidth	95
Channel decoder results	58
Channel Estimation	91
Channel flatness	50
Channel flatness difference	51
Channel flatness group delay	51
Configurable Subframes	99
Configuration Table	99
Constellation diagram	52
Constellation Selection	53
CSI RS Weights (Magnitude)	65
CSI RS Weights (Phase)	66

D

Digital Input Data Rate	87
Dither	86

E

Error in Subframes	99
EVM Calculation Method	92
EVM vs Carrier	40
EVM vs RB	43
EVM vs subframe	43
EVM vs symbol	41
EVM vs symbol x carrier	42
External Attenuation	72

F

Frequency	69
Frequency error vs symbol	44
Full Scale Level	87

H

Header Table	27
Home base station	83

I

Identity (Physical Layer)	98
Input Source	70
Interface	25

L

Low Pass	86
----------------	----

M

Measurement	
ACLR	47
alloc ID vs sym x carrier	57
allocation summary	55
Beamform Allocation Summary	63
beamforming	60
bit stream	56
capture buffer	34
CCDF	54
Cell RS Weights (Phase)	64
channel decoder results	58
channel flatness	50
channel flatness difference	51
channel flatness grdel	51
constellation	52
CSI RS Weights (Magnitude)	65
CSI RS Weights (Phase)	66
EVM (error vector magnitude)	40
EVM vs carrier	40
EVM vs RB	43
EVM vs subframe	43
EVM vs sym x carr	42
EVM vs symbol	41
freq err vs symbol	44
list	32
misc	54
numerical	32
on/off power	36
power spectrum	49
power vs RB PDSCH	49
power vs RB RS	50
power vs sym x carr	38
PVT (power over time)	34
result summary	32
signal flow	55
spectrum	45
spectrum mask	45
statistics	54
UE Specific RS Weights (Magnitude)	60
UE Specific RS Weights (Phase)	61
UE Specific RS Weights Difference (Magnitude)	62
UE Specific RS Weights Difference (Phase)	62
Multicarrier filter	90

N

Number of RB	95
Numerical results	32

O

On/off power	36
--------------------	----

P

P-/S-SYNC Tx antenna	106
P-SYNC Relative Power	106
PBCH	111
PCFICH	111
PDSCH reference data	93
PDSCH subframe detection	90
Phase Error	92
PHICH	112
Power spectrum	49
Power vs RB PDSCH	49
Power vs RB RS	50
Power vs symbol x carrier	38
PRB symbol offset	110

R

Reference Level	71
Relative power (P-SYNC)	106
Relative power (reference signal)	106
Relative power (S-SYNC)	106
Resource Blocks	95
Result Display	
Constellation Selection	53
Result summary	32

S

Scrambling of coded bits	93
Screen Layout	25
Selected Subframe	99
Setting	
P-/S-SYNC Tx antenna	106
Settings	
Auto	98
Auto PDSCH Demod	89
Balanced	86
boosting estimation	91
Capture Time	73
Cell ID	98
Cell Identity Group	98
Channel Bandwidth	95
Channel Estimation	91
Configurable Subframes	99
Configuration Table	99
Digital Input Data Rate	87
Dither	86
Error in Subframe	99
EVM Calculation Method	92
Ext Att	72
Frequency	69
Full Scale Level	87
Identity	98
Low Pass	86
multicarrier filter	90
Number of RB	95
P-SYNC relative power	106
PBCH	111
PCFICH	111
PDSCH reference data	93
PDSCH subframe detection	90
Phase	92
PHICH	112
PRB symbol offset	110
Ref Level	71
relative power	106

S-SYNC relative power	106
Scrambling of coded bits	93
Selected Subframe	99
Source	70
Standard	68
Swap I/Q	85
TDD UL/DL Allocations	96
Timing	92
Trigger level	81
Trigger mode	81
Trigger offset	81
Used Allocations	99
Signal flow	55
Softkey	
Const Selection	53
Software license	16
Source (Input)	70
Spectrum mask	45
Standard Selection	68
Status Bar	27
Subframe Configuration Table	99
Subframe Error	99
Swap I/Q	85

T

TDD UL/DL Allocations	96
Timing Error	92
Title Bar	27
Trigger level	81
Trigger mode	81
Trigger offset	81

U

UE Specific RS Weights (Magnitude)	60
UE Specific RS Weights (Phase)	61
UE Specific RS Weights Difference (Magnitude)	62
UE Specific RS Weights Difference (Phase)	62
Used Allocations	99